



INSTRUCTION MANUAL

(Translation of the original instructions originali)



EN

MONOBLOCK HEAT PUMP



FOR SAFE AND CORRECT USE, FOLLOW THESE INSTRUCTIONS.
KEEP THEM FOR FUTURE REFERENCE.

CONTENTS

INTRODUCTION	5
1 MANUFACTURER	6
1.1 Service centres.....	6
1.2 Technical assistance requests.....	6
2 SIGNIFICANT INFORMATION	7
2.1 Identification of the manual.....	7
2.2 Information on the manual.....	7
2.3 Intended users of the manual.....	8
2.4 Authorised operators.....	8
2.5 Consultation notes.....	9
2.6 Main abbreviations.....	10
2.7 Glossary.....	10
2.8 All rights reserved.....	11
2.9 Warranty.....	11
3 MACHINE IDENTIFICATION	12
3.1 Name.....	12
3.2 Series - Model.....	12
4 CONFORMITY	13
4.1 EC declaration of conformity.....	13
4.2 CE marking plate.....	14
5 MACHINE DESCRIPTION	15
5.1 Machine safety status.....	15
5.2 Intended use.....	15
5.3 Reasonably foreseeable misuse.....	16
5.4 General Notices.....	17
5.5 Dimensions.....	18
5.5.1 S-series dimensions (SP - SP-T).....	18
5.5.2 M-series dimensions (MP).....	19
5.5.3 L-series dimensions (LP - LR).....	20
5.5.4 L Plus series dimensions (LP Plus - LR Plus).....	21
5.5.5 XS-series dimensions XS - X) - HIGH VERSION.....	22
5.5.6 XS-series dimensions XS - X) - LOW VERSION.....	23
5.6 Circulators.....	24
5.7 Limits of use and technical data.....	25
5.8 Flow rate MIN. flow threshold.....	29
5.9 Permitted operating area.....	30
5.9.1 Heating and cooling modes for SP-T Series.....	30
5.9.2 Heating and cooling modes for MP - LP Series.....	31
5.9.3 Heating and cooling modes for SP - MP - LP - LP Plus Series.....	32
5.9.4 Heating and cooling modes for LR - LR Plus Series.....	33
5.9.5 Heating and cooling modes for XS-X Series.....	34
5.10 Characteristic curves of circulators.....	35
5.10.1 Circulator Wilo Para 25/8.....	35

5.10.2	Circulator Wilo Para 25/8 Plus	36
5.10.3	Circulator Wilo Para 25/9	37
5.10.4	Circulator Wilo Yonos Para HF 30/12.....	38
5.10.5	Circulator TEMPLARI GPA 32-17 H PRO/180	39
5.10.6	Circulator Grundfos UPM4XL 25-90.....	40
5.10.7	Circulator Grundfos UPMXL 25-125 180.....	41
5.10.8	Circulator Grundfos UPM10XL 25-125 180.....	42
5.10.9	Circulator TEMPLARI GPA 25-13 H PRO/180w.....	43
5.10.10	Circulator Grundfos UPM4K 15-75 130 PWM.....	44
5.10.11	Residual head	45
5.11	Operating modes.....	47
5.11.1	Heating.....	47
5.11.2	Cooling or defrosting.....	47
5.12	Structure of system with heat pump.....	48
5.13	Energy supply sources	48
5.14	Emissions.....	48
5.14.1	Airborne noise	48
5.15	Products used	48
5.16	Designation of the main components.....	49
5.16.1	Designation of the main components (Example Model SP-8T)	49
5.16.2	Name of main components (example model xs high version).....	51
5.17	HCC Remote control	53
5.18	Optional components	53
6	GUARDS AND PROTECTIVE DEVICES	54
6.1	Designation and functions.....	54
7	SAFETY AND INFORMATION SIGNS	56
7.1	Safety sign decals	56
8	RESIDUAL RISKS	58
9	PERSONAL PROTECTIVE EQUIPMENT (PPE)	59
10	WORK STATIONS	60
11	TRANSPORT AND HANDLING	61
11.1	Pack and pack contents	61
11.2	Unpacking the machine components	61
11.3	Handling with crane or overhead crane	61
11.4	Handling with forklift truck	63
12	STORAGE.....	64
13	INSTALLATION	64
13.1	Choice of installation site.....	64
13.2	Safety zone (for R290 refrigerant type only)	65
13.2.1	Safety zone for ground (or flat roof) installation	66
13.2.2	Safety zone for ground installation in front of a building wall	66
13.2.3	Safety zone for ground installation in a building corner.....	67
13.2.4	Safety zone for wall installation in front of a building wall	67
13.2.5	Safety zone for wall installation in a building corner.....	67

13.3 Assembly equipment.....	68
13.4 Useful components for installation	68
13.5 Assembling the machine	68
13.6 Levelling the machine.....	69
13.7 Installing the probes	71
13.8 Installing the venting valves	71
13.9 Connections	71
13.9.1 Connection to the water energy source.....	71
13.9.2 Choice of system layout	73
13.9.3 Connection to the electrical energy source	77
13.9.4 Installation of the XS high version heat pump.....	78
13.9.5 Minimum clearances for heat pump installation - XS high version.....	78
13.9.6 Installation of utilities (heat pump supply/return, electrical wiring, condensate outlet).....	79
13.9.7 Installation of the XS low version heat pump	87
13.9.8 Minimum clearances for heat pump installation XS low version	88
13.9.9 Installation of utilities (heat pump supply/return, electrical wiring, condensate outlet).....	88
13.9.10 indicative section for cables and internal protections	98
13.10 Probes and remote panel.....	99
13.11 Terminal wiring	100
13.11.1 Outdoor unit µPC wiring	100
13.11.2 Digital outputs.....	101
13.11.3 Digital inputs.....	101
13.11.4 Analog outputs	101
13.11.5 Analog inputs.....	101
13.11.6 Electronic board µPC	102
13.11.7 SG-Probe electronic board.....	103
13.11.8 Secondary electrical panel terminal board - K-Touch panel connection.....	104
13.11.9 Terminal block of secondary electrical cabinet for dual-supply heat pump	105
13.11.10 T-split module	106
13.11.11 Three-way valve connection.....	107
13.11.12 Plant aware function.....	108
13.11.13 Electrical connection - "Multi-KITA"	110
13.12 SG Ready protocol.....	111
13.13 Smart-Grid Operation.....	112
13.13.1 Switchboard xs.....	113
13.13.2 Electronic board SG-Probe	114
13.13.3 PGD (screen)	116
14 USE OF THE MACHINE	117
14.1 Checks and operations before commissioning.....	117
14.2 Starting the machine for testing	118
14.3 Checks and operations after commissioning.....	118
14.4 Testing.....	118
14.5 K-Touch panel	120
14.5.1 General Notices.....	120
14.5.2 Preparing the machine for connecting the K-Touch panel.....	120
14.6 Connection to the Kita heat pump.....	122
14.7 HCC Connection (Example).....	123

14.8 PGD control terminal (optional).....	124
14.8.1 Fastening the terminal.....	124
14.8.2 Terminal functions	125
14.8.3 Terminal display.....	126
14.9 Main menu.....	127
14.10 ON-OFF menu	128
14.11 Clock/Time slots Menu.....	130
14.12 Inputs/Outputs menu.....	131
14.13 Alarm Log menu.....	133
14.14 Card change menu.....	133
14.15 Service menu	133
14.16 Alarms.....	140
14.17 Starting the machine	144
14.18 Heat Pump settings.....	145
14.19 Machine shutdown	145
14.20 Operating method to be followed in case of injuries or breakdowns.....	146
14.21 Operating method to be followed in case of fire.....	146
15 TROUBLESHOOTING.....	147
15.1 Warnings	148
16 MAINTENANCE.....	148
16.1 General Notices.....	148
16.2 Routine maintenance	149
16.2.1 Routine maintenance table.....	149
16.3 Maintenance sheets	149
16.4 Periodic check of efficiency of guards and protective devices	154
16.5 Unscheduled maintenance.....	155
16.6 Service instructions	155
17 INSTRUCTIONS FOR DISABLING AND DISPOSAL.....	156
18 SPARE PARTS	157
18.1 Ordering procedure	157
19 ANNEXES.....	158
19.1 Instructions for handling the pack.....	158
19.2 Hand signals (Directive 92/58/EEC).....	159
19.3 Declaration of consignment of the instruction manual.....	160
19.4 Electrical schematics.....	160
19.4.1 Electrical schematic - single power supply.....	160
19.4.2 Electrical schematic - dual power supply	162
19.5 Internal wiring cable diagram	163
19.5.1 Circulation pump wiring	163
19.5.2 Fan Wiring.....	163
19.5.3 4-way valve and casing heating element wiring.....	163
19.5.4 Probe wiring	164
20 SUMMARY OF CHANGES.....	165

INTRODUCTION

Dear Customer,

first of all, we would like to thank you for choosing your new **“MONOBLOCK HEAT PUMP - KITA model”**.

We are confident that you will be fully satisfied with the performance and reliability of your new machine, assured by our focus on innovative processes and our attention to technical and commercial developments on the market.

We look forward to assisting you with your future requirements and remain at your complete disposal should you wish to take advantage of our experience and know-how to ensure the optimal solution to your needs.



1 MANUFACTURER

Name	TEMPLARI SPA
Address	Via C. Battisti, 169 - 35031 Abano Terme (PD) Italy
Tel.	+39 049 8597400
E-mail	info@templari.com
Website	www.templari.com

TAB. 1 (Manufacturer)

1.1 SERVICE CENTRES

Contact the manufacturer for Service Centre details.

1.2 TECHNICAL ASSISTANCE REQUESTS

Technical assistance requests must be addressed directly to the Manufacturer, specifying:

- 1) Machine name
- 2) Machine model
- 3) Serial number (s. CE marking or EC declaration of conformity)
- 4) Year of construction
- 5) Type of problem

2 SIGNIFICANT INFORMATION

2.1 IDENTIFICATION OF THE MANUAL

This document is the “**Instruction manual**” (**Translation of the original instructions**), hereinafter “manual”. It has been prepared in compliance with the essential safety requirements of the Machinery Directive 2006/42/EC (Annex I - points 1.7.4, 1.7.4.1 and 1.7.4.2).

The manual is identified by means of the following data given on the cover and at the foot of the pages:

- Identification code
- Issue
- Revision
- Language code EN (English)

2.2 INFORMATION ON THE MANUAL



⚠ CAUTION

THIS MANUAL MUST BE KEPT CONSTANTLY AT THE DISPOSAL OF AUTHORISED OPERATORS IN A WELL-PROTECTED PLACE NEAR THE MACHINE.

THIS MANUAL MUST BE TRANSFERRED, TOGETHER WITH THE MACHINE, TO ANY NEW OWNER/USER.

MAKE A NOTE OF THE DOCUMENT IDENTIFICATION DETAILS: CODE, ISSUE AND REVISION (**S. PAR. 2.1**) TO REQUEST A COPY OF THE MANUAL FROM THE MANUFACTURER IN THE EVENT OF LOSS OR DAMAGE.

THIS MANUAL REFLECTS THE STATE OF THE ART FIELD AT THE TIME OF SALE OF THE MACHINE AND IT CANNOT BE HELD TO BE INADEQUATE IN RESPECT OF POSSIBLE FUTURE UPDATES TO REFLECT TECHNOLOGICAL PROGRESS.



⚠ CAUTION

BEFORE USING THE MACHINE YOU MUST READ ALL PARTS OF THIS MANUAL AND BE CERTAIN YOU HAVE UNDERSTOOD THEM.

THIS MANUAL IS AN INTEGRAL PART OF THE MACHINE: KEEP IT FOR FUTURE CONSULTATION.

ANY FAILURE TO COMPLY WITH THE INSTRUCTIONS AND WARNINGS GIVEN IN THIS MANUAL WILL INVALIDATE THE WARRANTY.

THE MANUFACTURER DECLINES ALL LIABILITY FOR INJURY OF PERSONS OR ANIMALS OR DAMAGE TO PROPERTY CAUSED BY NONCOMPLIANCE WITH THE INSTRUCTIONS AND WARNINGS GIVEN IN THIS MANUAL AND BY IMPROPER USE OF THE MACHINE.

2.3 INTENDED USERS OF THE MANUAL

This manual is for the exclusive attention of operators authorised to use and service the machine based on the specific technical-professional skills required for the type of procedure in question (**s. par. 2.4**).







2.4 AUTHORISED OPERATORS

⚠ WARNING











AUTHORISED OPERATORS MUST PERFORM EXCLUSIVELY THE OPERATIONS ON THE MACHINE FOR WHICH THEY ARE SPECIFICALLY RESPONSIBLE.

BEFORE CARRYING OUT ANY WORK ON THE MACHINE, AUTHORISED OPERATORS MUST MAKE SURE THEY ARE IN POSSESSION OF THEIR FULL MENTAL AND PHYSICAL FACULTIES TO ENSURE CONSTANT COMPLIANCE WITH THE NECESSARY SAFETY CONDITIONS.





Symbol	Description of technical - professional abilities
	CONSUMER An unqualified operator, who uses the machine for non-professional purposes.
	MACHINE OPERATOR A professionally trained operator who, in compliance with the legislation in force in the place in which the machine is put into service, is permitted exclusively to: <ul style="list-style-type: none"> • carry out certain routine maintenance jobs (s. par. 16.2) equipped with the personal protective equipment (PPE) specified in chap. 9 .
	MACHINE HANDLING OPERATOR A professionally trained operator who, in compliance with statutory legislation in force in the country in which the machine is put into service, is authorised to operate forklift trucks, overhead travelling cranes or jib cranes, for transport, handling and unpacking of the machine and/or parts of the machine in safety, using the hand signals set down in European Directive 92/58/EEC, and equipped with the personal protective equipment (PPE) specified in chap. 9 .
	INSTALLER A qualified technician (electrician or refrigeration technician who meets the professional technical requirements under the regulations in force in the country of use), qualified to install the machine and put it into service on behalf of the Purchaser or the Authorized Dealer.
	MANUFACTURER'S TECHNICIAN Qualified technician, supplied by the Manufacturer and/or by the Service Centre, who has specific knowledge of the machine and is enabled to provide the necessary technical assistance, routine and unscheduled maintenance operations or operations not described in this manual, equipped with the personal protective equipment maintenance (PPE) specified in chap. 9 .
	SUPERVISOR (Person present and recognised only in the workplace) Person who, due to their professional skills and within the limits of the appropriate hierarchical and functional powers in relation to the nature of the assignment, supervises the work activity and guarantees implementation of the instructions received, monitoring correct performance by the workers and exercising a functional power of initiative.
	FIRST AID MANAGER Person appointed by the company to carry out emergency actions in the workplace, which are intended to preserve the life of the injured person, pending the arrival of qualified personnel
	FIRE SAFETY MANAGER Person appointed by the company to intervene in the event of a fire; "intervene" also means only evaluating the extent of the fire and deciding to intervene by using the fire extinguishers inside the facility. In fact, these are the only persons authorised to use them.

TAB. 2 (Authorised operators)

2.5 CONSULTATION NOTES

	Bold text: Highlights significant phrases and references in the text.
	Generic or specific danger sign: Highlights health and safety risks affecting authorised operators and/or risks of machine damage or malfunction.
	Generic or dedicated obligation sign: Indicates a prescription (obligation to perform an action).
	Generic or dedicated prohibition sign: Highlights a prohibition of performing specific actions.
	EX danger sign (potentially explosive atmosphere): Highlights an explosion hazard.
	Crossed-out wheelee bin: Highlights the prohibition of discarding waste electrical or electronic equipment (WEEE) with normal household refuse.
	Sign showing the obligation to read the manual: To use the machine safely you must read and understand all parts of this instruction manual and the attached technical documentation.
	Sign showing the obligation to disconnect the machine before carrying out maintenance or repairs: To work on the machine safely it must be put in “safety status” (s. par. 5.1).
	Authorised operator sign: The symbol at the beginning of a chapter or paragraph provides an indication of the authorised operators (s. par. 2.4) in relation to the operations described in the chapter or paragraph.

TAB. 3 (Consultation notes)

	⚠ DANGER
	IDENTIFIES A DANGER WITH A HIGH LEVEL OF RISK THAT CAN RESULT IN DEATH OR SERIOUS INJURY.
	⚠ WARNING
	IDENTIFIES A DANGER WITH A MEDIUM LEVEL OF RISK THAT CAN RESULT IN DEATH OR SERIOUS INJURY.
	⚠ CAUTION
	IDENTIFIES A DANGER WITH A LOW LEVEL OF RISK THAT CAN RESULT IN MINOR OR NON-SERIOUS INJURY.
	INFORMATION
	IDENTIFIES A PIECE OF SIGNIFICANT INFORMATION.

2.6 MAIN ABBREVIATIONS

approx.	Approximately	par.	Paragraph
chap.	Chapter	Pos.	Position
PPE	Personal protective equipment	q.ty	Quantity
RH	Right hand	Ref.	Reference
etc.	Etcetera	LH	Left hand
e.g.	Example	s	Seconds
FIG.	Figure(s)	TAB.	Table
h	Hours	s.	See
MAX.	Maximum	÷	From, to
MIN.	Minimum	∅	Diameter
min	Minutes	>	Greater than
mm	Millimetres	≥	Greater than or equal to
NO.	Proposal Number	<	Less than
p.	Page	≤	Less than or equal to

TAB. 4 (Main abbreviations)

2.7 GLOSSARY

Term	Definition
Full-inverter	Technology allowing compressor and fan modulation via inverter (instead of ON/OFF mode).
Circulator	Technical water circulation pump (hydraulic circuit)
Puffer	Insulated tank for technical water storage (closed circuit)
Ethylene or propylene glycol	Substance that can be added to technical water (closed circuit) to lower the freezing temperature. Increases the risk of corrosion and drops in pressure. Ethylene glycol is a cheaper, more widely used and toxic alcoholic compound. Propylene glycol is an organic compound with lower toxicity.
Plant Aware	A function that changes the ignition hysteresis relative to the heat pump temperature setpoint in response to the opening or closing of a clean contact. The function is available on heat pump units equipped with flowmeter. If the clean contact is closed, the machine works to reach the setpoint with standard ignition hysteresis. If the clean contact is open, the heat pump is in "sleep" mode and will increase the hysteresis in order to avoid continuous topping up of the unused inertia tank.
Magnetic dirt separator	It retains impurities and almost 100% of ferrous oxides (including magnetite) that form in the hydraulic system due to corrosive phenomena

TAB. 5 (Glossary)

2.8 ALL RIGHTS RESERVED

In compliance with ISO 16016, it is prohibited to transfer this manual to third parties or make copies of the manual. Furthermore, the contents of the manual must not be used by or disclosed to third parties without prior authorisation. Any violation of these prescriptions results in liability for compensation in respect of damages. All rights deriving from the use of patented inventions, industrial utility models, drawings or models, are strictly reserved. All the trademarks appearing in this document belong to their respective proprietors.

2.9 WARRANTY



INFORMATION

ANY FAILURE TO COMPLY WITH THE INSTRUCTIONS AND WARNINGS GIVEN IN THIS MANUAL WILL INVALIDATE THE WARRANTY.



INFORMATION

A HARD COPY OF THE WARRANTY CONDITIONS IS ATTACHED TO THIS MANUAL.

3 MACHINE IDENTIFICATION

3.1 NAME

The name of the machine described herein is:

MONOBLOCK HEAT PUMP - KITA

3.2 SERIES - MODEL

The series and the model are named as follows:

Series	Model	Compressor type	Heating capacity (*) A 7 / W 35 (kW)	Power supply		Refrigerant		
				230 V 50 Hz	400 V 50 Hz	Type (GWP)	Q.ty (kg)	CO _{2eq} (ton)
XS	XS-7,5	Twin rotary	7,5	x	x	R290 (GWP = 3)	0,7	0,0021
	XS-9		9	x	x			
	X-7,5		7,5	x	x			
	X-9		9	x	x			
SP-T	SP-8T		8	x	x		1,35	0,004
	SP-10T		10	x	x		1,5	0,0045
	SP-12T		12	x	x			
HRP	HRP-10		10	x	x		1,35	0,0041
	HRP-12	12	x	x				
	HRP-14	14	x	x				
	HRP-16	16	x	x				
SP	SP-8	8	x	x	1,35		0,004	
	SP-10	10	x	x	1,5	0,0045		
	SP-12	12	x	x				
MP	MP-14	14	x	x	1,7	0,0051		
	MP-16	16	x	x				
	MP-18	18		x				
	MP-20	20		x				
LP	LP-22	22		x	3,5	0,0105		
	LP-26	26		x				
	LP-28	28		x				
	LP-32	32		x				
	LP-35	35		x				
LP Plus	LP Plus-35	35		x	4,5	0,0135		
	LP Plus-40	40		x				
LR	LR-35	34,8		x	R32 (GWP = 675)	7,2	4,387	
	LR-35 Cold	35		x				
LR Plus	LR Plus-45	45		x	7,4	4,995		

(*) According to EN 14511 - For example **A 7 / W 35** (A 7 = air inlet 7 °C - W 35 = water outlet 35 °C)

TAB. 6 (Series - Model)

4 CONFORMITY

4.1 EC DECLARATION OF CONFORMITY



INFORMATION	
A HARD COPY OF THE EC DECLARATION OF CONFORMITY IS ATTACHED TO THIS MANUAL..	

Manufacturer				TEMPLARI SPA Via C. Battisti, 169 35031 Abano Terme (PD) Italy Tel. +39 049 8597400 infotemplari.com - www.templari.com	
Person authorised to compile the technical file					
Name and address					
Declares that the machine identified as follows					
Name		Monoblock HEAT PUMP - KITA			
Series - Model					
Serial number					
Complies with the provisions of the following directives					
2006/42/EC		Directive of the European Parliament and of the Council of 17 May 2006 on machinery, and amending Directive 95/16/EC (recast)			
2014/68/EU		Directive of the European Parliament and of the Council of 15 May 2014 on the harmonisation of the laws of the Member States relating to the making available on the market of pressure equipment (recast)			
2014/30/EU		Directive of the European Parliament and of the Council of 26 February 2014 on the harmonisation of the laws of the Member States relating to electromagnetic compatibility (recast)			
2014/35/EU		Directive of the European Parliament and of the Council of 26 February 2014 on the harmonisation of the laws of the Member States relating to the making available on the market of electrical equipment designed for use within certain voltage limits (recast)			
2009/125/EC		Directive 2009/125/EC of the European Parliament and of the Council, of 21 October 2009, establishing a framework for the setting of ecodesign requirements for energy-related products (recast)			
2011/65/EU		Directive 2011/65/EU of the European Parliament and of the Council, of 8 June 2011, on the restriction of the use of certain hazardous substances in electrical and electronic equipment (recast)			
(EU) No 811/2013		Commission delegated Regulation (EU) No 811/2013, of 18 February 2013, supplementing Directive 2010/30/EU of the European Parliament and of the Council with regard to the energy labelling of space heaters, combination heaters, packages of space heater, temperature control and solar device and packages of combination heater, temperature control and solar device			
(EU) No 813/2013		Commission regulation (EU) No 813/2013, of 2 August 2013, implementing Directive 2009/125/EC of the European Parliament and of the Council with regard to ecodesign requirements for space heaters and combination heaters			
(EU) 2017/1369		Regulation (EU) 2017/1369 of the European Parliament and of the Council, of 4 July 2017, setting a framework for energy labelling and repealing Directive 2010/30/EU			
Person authorised to draft the declaration					
Name and position		Ing. Gianluca Masiero - Chief Executive Officer			
Place		Date/...../.....		Signature	

4.2 CE MARKING PLATE

The CE marking plate is affixed to the exterior of the machine (s. FIG. 1) in compliance with Directive 2006/42/EC.



CAUTION
 AT THE TIME OF PURCHASE, MAKE SURE THE MACHINE IS EQUIPPED WITH THE CE MARKING PLATE. IF THE PLATE IS MISSING, INFORM THE MANUFACTURER OR SERVICE CENTRE IMMEDIATELY.

MACHINES LACKING THE CE MARKING PLATE AND DATA ARE NONCONFORMING AND MUST NOT BE USED.



INFORMATION

THE DATA PLATE SHOWS THE TYPE OF REFRIGERANT USED (R290 OR R32) IN THE MACHINE SERIES.

Templari srl
 Via Pitagora 20/A 35030 Rubano - PD
 info@templari.com +39 049 8597400

Heat pump/Chiller / Pompa di calore

Serial number / Numero di serie	K-----
Model number / Numero modello	4.1.5.3
Model name / Nome modello	KITA LR PLUS
Year of production / Anno di produzione	2023
Heating capacity / Potenza termica @ A7/W35	50 kW
Cooling capacity / Potenza frigorifera @ A35/W7	45 kW
Rated voltage / Alimentazione	3~400V - 50 Hz
Max operating current / Max corrente assorbita	40A
Refrigerant / Refrigerante	R32
Refrigerant Charge / Carica di refrigerante	7,4 kg
CO2 equivalents / CO2 equivalente	4995 Kg
PED Category / Categoria PED	II
Max permissible pressure / Pressione massima ammissibile	PS 40,5 bar
Max permissible pressure secondary circuit / Pressione massima ammissibile circuito secondario	PS 2,5 bar
Net Weight (Outdoor Unit / Indoor Unit) / Peso netto (unità esterna/unità interna)	320 Kg

-----23
 Made in Italy

0425

Contains fluorinated
 greenhouse gases
 covered by
 the Kyoto Protocol

R-32

Note: Heating capacity tested in standard condition of temperature: external air temperature of 7°C (dry bulb) and 6°C (wet bulb), water temperature inlet/outlet 30/35°C. Cooling capacity tested in standard condition of temperature: external air temperature of 35°C (dry bulb), water temperature inlet/outlet 12/7°C. Tests in accordance with EN14511.

FIG. 1 (CE marking plate)

5 MACHINE DESCRIPTION

The monoblock heat pump is used for the production of heating and cooling thermal energy that can be implemented through the switching of the 4-way valve and for the production of domestic hot water with a special DHW (domestic hot water) management module consisting of relays, temperature sensors and a 3-way valve.

The monoblock heat pump is a full-inverter machine.

The machine is controlled by a remote control.

The machine is composed of the following main components:

- Frame (load-bearing structure)
- Compressor
- Inverter
- Heat exchanger
- Circulation pump (circulator)
- Fan
- A series of valves
- Electrical panel
- Remote control

5.1 MACHINE SAFETY STATUS



The machine is in “**safety status**” when it is isolated from the energy sources, with the energy isolating device locked, residual energy dissipated and without the presence of any conditions that could negatively impact the general level of safety.

Proceed as follows to set the machine to “**safety status**”:

- 1) Stop the machine from the HCC remote control (**s. par. 14.19**), or from the terminal (**s. par. 14.18**) wait for the compressor to shut down normally and for the machine components to reach room temperature.
- 2) Disconnect the power supply to the machine by turning the main power switch (supplied by the customer) to **Pos. “0-OFF”** (in the case of a dual power supply machine, disconnect both power supplies)
- 3) Close the valves of the hydraulic system.
- 4) If the machine is left switched off and there is a risk of icing up, in the absence of antifreeze valves, empty the hydraulic system

5.2 INTENDED USE

Field of application	Civil and industrial sector
Place of use	Outdoors, in sufficiently illuminated and well-ventilated premises protected from the weather and in compliance with the legislative provisions in force in the country in which the machine is put into service. The machine must be sited on a flat, level and stable surface that ensures stability of installation in relation to its dimensions (s. par. 5.5) and weight (s. par. 11.1 - TAB. 22)
Intended use	The machine is used for the production of heating and cooling thermal energy and for the production of domestic hot water. The monoblock heat pump is a full-inverter machine. The machine is controlled by a remote control.
Machine operators	No. 1 authorised operator in possession of the technical and professional attributes described in par. 2.4

TAB. 7 (Intended use)

5.3 REASONABLY FORESEEABLE MISUSE

The machine is designed and built for the intended use described in **par. 5.2**; in order to guarantee the safety of the authorised operators and efficiency of the machine at all times, it is prohibited to use the machine for alternative purposes.



⚠ DANGER

IT IS PROHIBITED TO PUT THE MACHINE INTO SERVICE IN SITES SUBJECT TO THE PRESENCE OF A POTENTIALLY EXPLOSIVE ATMOSPHERE AND/OR IN THE PRESENCE OF COMBUSTIBLE DUSTS (E.G.: DUST FROM WOOD, FLOUR, SUGAR AND GRAINS).

⚠ DANGER

-
- 1) IT IS PROHIBITED TO USE THE MACHINE FOR IMPROPER USES OR FOR USES OTHER THAN THOSE SPECIFIED BY THE MANUFACTURER (**S. PAR. 5.2**)
 - 2) THE MACHINE MUST NOT BE USED BY UNAUTHORISED PERSONS (**S. PAR. 2.4**) OR PERSONS NOT IN POSSESSION OF THEIR FULL MENTAL-PHYSICAL FACULTIES
 - 3) IT IS PROHIBITED TO USE THE MACHINE WITHOUT GUARDS AND PROTECTIVE DEVICES
 - 4) IT IS PROHIBITED TO NEUTRALISE, TAMPER WITH, MANIPULATE OR BYPASS THE GUARDS AND PROTECTIVE DEVICES INSTALLED ON THE MACHINE
 - 5) IT IS PROHIBITED TO CLIMB ONTO THE MACHINE
 - 6) IT IS FORBIDDEN TO TILT THE HEAT PUMP MORE THAN 45° (IN ANY DIRECTION) DURING TRANSPORT.
 - 7) IT IS FORBIDDEN TO COVER, EVEN PARTIALLY, THE EXTRACTION AND EXHAUST ZONE
 - 8) IT IS FORBIDDEN TO INSTALL THE MACHINE NEAR THE WALL
 - 9) IT IS FORBIDDEN TO INSTALL THE MACHINE NEAR A HEAT SOURCE
 - 10) IT IS FORBIDDEN TO INSTALL THE MACHINE NEAR FLAMMABLE SUBSTANCES
 - 11) IT IS FORBIDDEN TO INSTALL THE MACHINE NEAR VENTILATION OPENINGS OF ADJACENT BUILDINGS
 - 12) IT IS FORBIDDEN TO INSTALL THE MACHINE UNDER DECIDUOUS TREES
 - 13) IT IS FORBIDDEN TO INSTALL THE MACHINE IN DUSTY OR CORROSIVE PLACES
 - 14) IT IS FORBIDDEN TO INSTALL THE MACHINE NEAR AIR EXHAUST SHAFTS
 - 15) IT IS FORBIDDEN FOR THE FAN OUTLET TO FACE WINDOWS OR DOORS
 - 16) IT IS FORBIDDEN TO OPERATE THE MACHINE WITH TEMPERATURES THAT ARE TOO HIGH OR TOO LOW (**S. PAR. 5.7**)

⚠ WARNING

-
- 1) IT IS PROHIBITED TO MAKE ANY ALTERATIONS TO THE MACHINE, OTHERWISE THE WARRANTY AND CE CONFORMITY WILL BE VOID
 - 2) IT IS PROHIBITED TO FIT NON-ORIGINAL EQUIPMENT, ACCESSORIES AND/OR SPARE PARTS ON THE MACHINE
 - 3) IT IS PROHIBITED TO USE PRODUCTS OTHER THAN THOSE SPECIFIED BY THE MANUFACTURER (**S. PAR. 5.15**)
 - 4) IT IS PROHIBITED TO PLACE OBJECTS ON THE MACHINE
 - 5) COMPLY WITH COUNTRY-SPECIFIC BUILDING REGULATIONS.

⚠ WARNING

-
- 1) IT IS MANDATORY TO COMPLY WITH THE SPECIFIC BUILDING REGULATIONS OF THE COUNTRIES IN WHICH THE MACHINE IS PUT INTO SERVICE
 - 2) IT IS MANDATORY TO INSTALL THE MACHINE 25 cm FROM THE GROUND AND WITH ADEQUATE COVERING IF THE MACHINE IS INSTALLED WHERE SNOWFALL OCCURS, TO AVOID OBSTRUCTIONS OF THE INTAKE AND CONDENSATE DRAINAGE AREA.

INFORMATION

DURING SUMMER OPERATION, AN ANTIFREEZE PROTECTION PREVENTS THE WATER IN THE PLANT FROM FREEZING.

THE MONOBLOCK HEAT PUMP IS EQUIPPED WITH A PROBE THAT MONITORS THE DISCHARGE TEMPERATURE OF THE COMPRESSOR. THE MACHINE'S COMPUTER ENSURES THAT THE DISCHARGE TEMPERATURE DOES NOT EXCEED THE MAXIMUM PERMITTED VALUE.

5.4 GENERAL NOTICES**⚠ WARNING**

THE CHOICE AND USE OF THE MACHINE TO SERVE THE AIR CONDITIONING SYSTEM MUST BE IMPLEMENTED BY QUALIFIED PERSONNEL ACCORDING TO THE REGULATIONS IN FORCE IN THE COUNTRY WHERE THE MACHINE IS BEING USED IN ORDER TO FULLY MEET THE SYSTEM'S REQUIREMENTS.

INSTALLATION, COMMISSIONING AND MAINTENANCE MUST BE CARRIED OUT BY QUALIFIED PERSONNEL CAPABLE OF ASSESSING THE PRESENCE OF RISK FACTORS OR MACHINE MALFUNCTION.

THE MACHINE IS SUPPLIED COMPLETE WITH ALL OPTIONS AND FUNCTIONS DIRECTLY FROM THE MANUFACTURER. NO TAMPERING WITH THE REFRIGERATOR OR SOFTWARE IS PERMITTED. ANY TAMPERING WILL INVALIDATE THE MACHINE'S FUNCTIONS AND THE MANUFACTURER'S LIABILITY.

IT IS MANDATORY TO CARRY OUT PERIODIC INSPECTIONS AND PROPER MAINTENANCE OF THE MACHINE TO GUARANTEE THE FUNCTIONALITY AND LIFE OF THE MACHINE.

IN THE EVENT OF A MALFUNCTION, CHECK THE ERROR CODE ON THE CONTROL PANEL AND, IF NECESSARY, CONTACT THE INSTALLER. IF NECESSARY, REQUEST ORIGINAL SPARE PARTS.

AIRFLOW IN THE INTAKE AND DISCHARGE ZONE CAN LEAD TO A GREATER BUILD-UP OF IMPURITIES IF THE MACHINE IS INSTALLED CLOSE TO THE WALL.

THE COOLER OUTDOOR AIR MUST ESCAPE IN SUCH A WAY AS NOT TO INCREASE THE THERMAL DISPERSION OF THE SURROUNDING HEATED ENVIRONMENTS.

THE IMPURITY COLLECTOR, NOT PROVIDED AS STANDARD BUT SUPPLIED AT THE REQUEST OF THE CUSTOMER, MUST BE MOUNTED ON THE HEATING RETURN UPSTREAM OF THE HEAT PUMP.

IT IS NOT ALLOWED TO INSTALL IT IN NICHE OR INTERNAL COURTYARDS, BECAUSE THE COOLED AIR ACCUMULATES ON THE GROUND AND IN CASE OF PROLONGED OPERATION WOULD BE SUCKED BACK BY THE HEAT PUMP.

THE FREEZING LIMIT MAY VARY DEPENDING ON THE CLIMATIC REGION. COMPLY WITH THE REGULATIONS IN FORCE FOR THE COUNTRIES IN QUESTION.

RESPECT THE RIGHT-HANDED ROTATION FIELD: IN CASE OF INCORRECT WIRING, START-UP OF THE HEAT PUMP WILL BE OBSTRUCTED. THE HEAT PUMP PROGRAMMER DISPLAYS THE RELEVANT WARNING MESSAGE (CORRECT THE WIRING).

OPERATION OF THE HEAT PUMP WITH EXCESSIVELY LOW SYSTEM TEMPERATURES CAN STOP IT FROM WORKING ALTOGETHER. FOR COMMISSIONING (**V. PAR. 14.2**).

THE APPLIANCE IS NOT SUITABLE FOR USE WITH A FREQUENCY CONVERTER. IF THE MACHINE IS DE-ENERGIZED (DISCONNECTED FROM THE MAINS) FOR LONG PERIODS, DO NOT INTERRUPT THE OIL HEATING PROCEDURE THAT STARTS WHEN THE MACHINE IS POWERED AGAIN. THIS PROCEDURE IS TO PREVENT THE COMPRESSOR FROM BREAKING.



5.5 DIMENSIONS

5.5.1 S-SERIES DIMENSIONS (SP - SP-T)

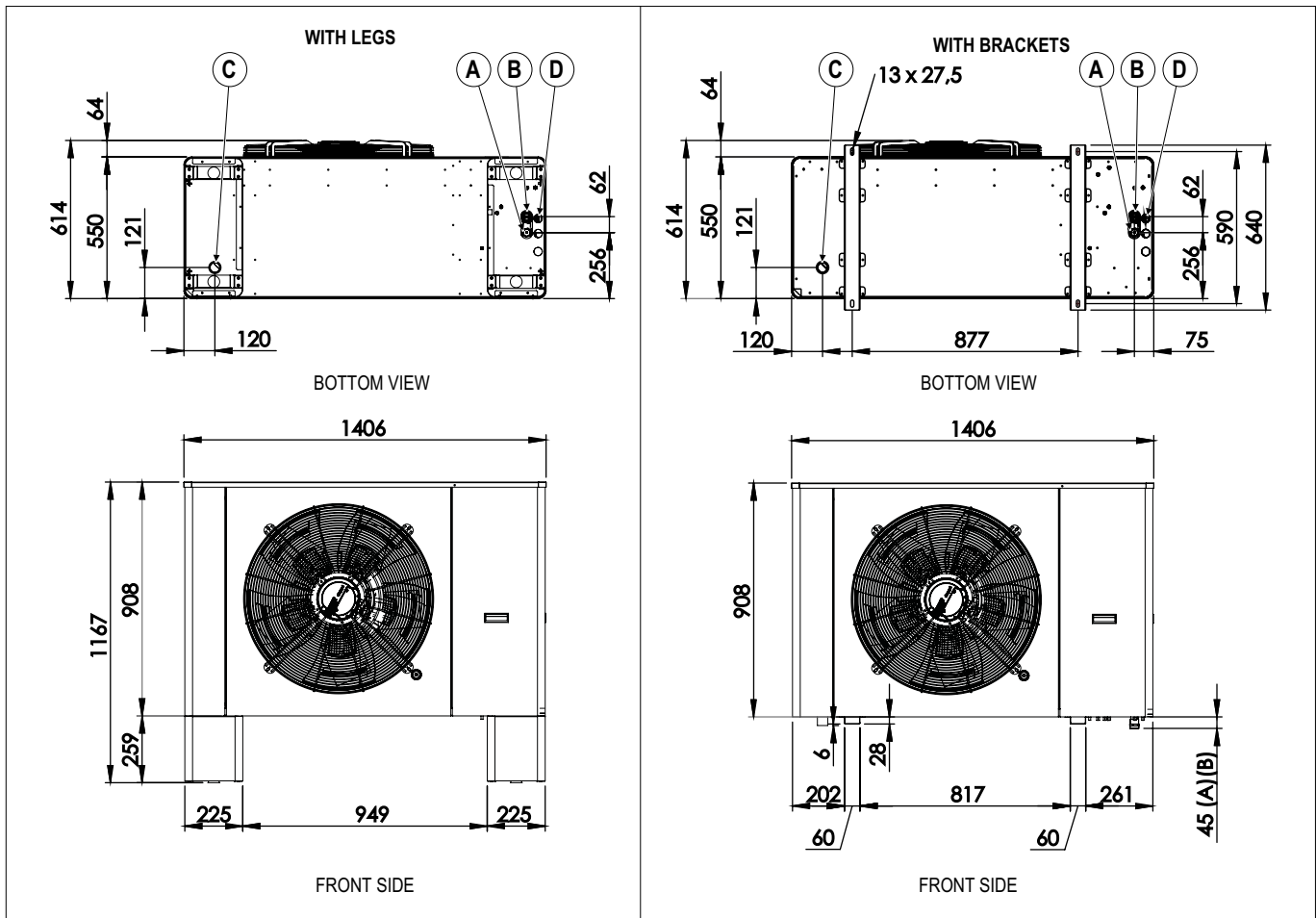

FIG. 2 (Dimensions of S-series - SP - SP-T - with legs and with brackets)

Ref.	
A	Water inlet connection - 1" fitting
B	Water outlet connection - 1" fitting
C	Condensate drain connection with external diameter \varnothing 40 mm
D	Electric cable gland

TAB. 8 (S-series - SP - SP-T connection dimensions)

5.5.2 M-SERIES DIMENSIONS (MP)

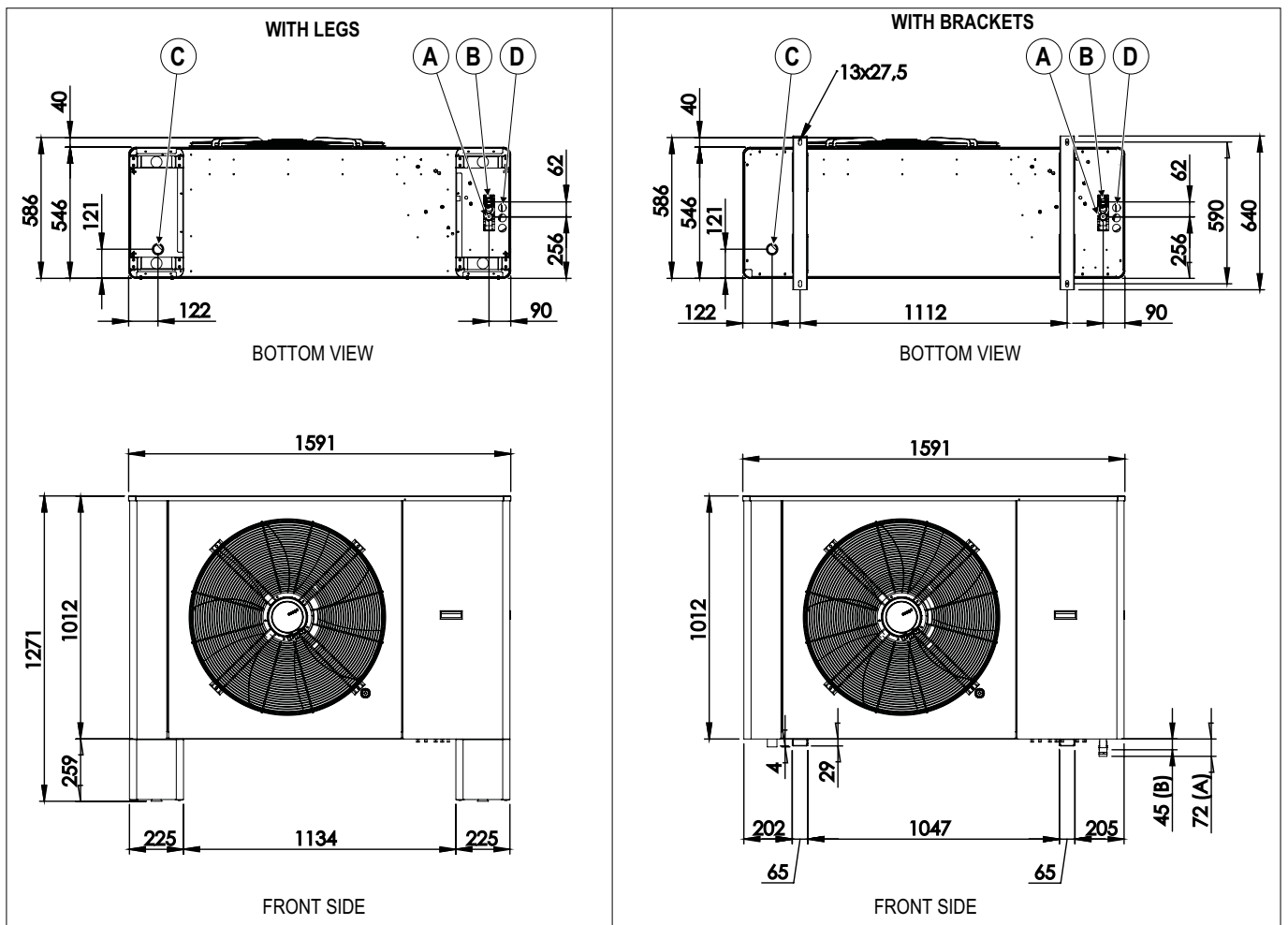

FIG. 3 (Dimensions of M-series - MP - with legs and with brackets)

Ref.	
A	Water inlet connection - 1" fitting
B	Water outlet connection - 1" fitting
C	Condensate drain connection with external diameter \varnothing 40 mm
D	Electric cable gland

TAB. 9 (M-series - MP connection dimensions)

5.5.3 L-SERIES DIMENSIONS (LP - LR)

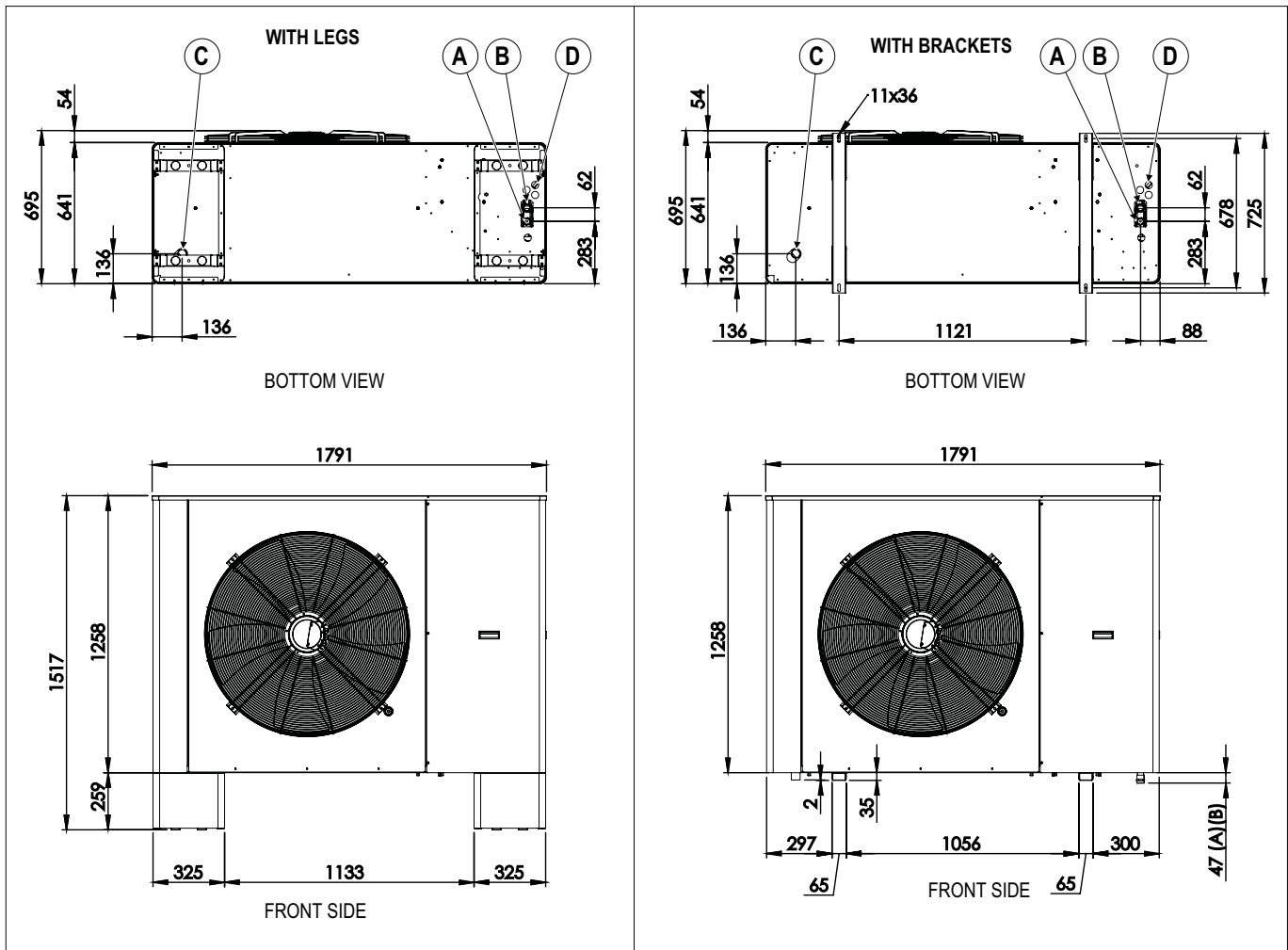

FIG. 4 (Dimensions of L-series - LP - LR - with legs and with brackets)

Ref.	
A	Water inlet connection - 1" fitting
B	Water outlet connection - 1" fitting
C	Condensate drain connection with external diameter \varnothing 40 mm
D	Electric cable gland

TAB. 10 (L-series - LP - LR connection dimensions)

5.5.4 L PLUS SERIES DIMENSIONS (LP PLUS - LR PLUS)

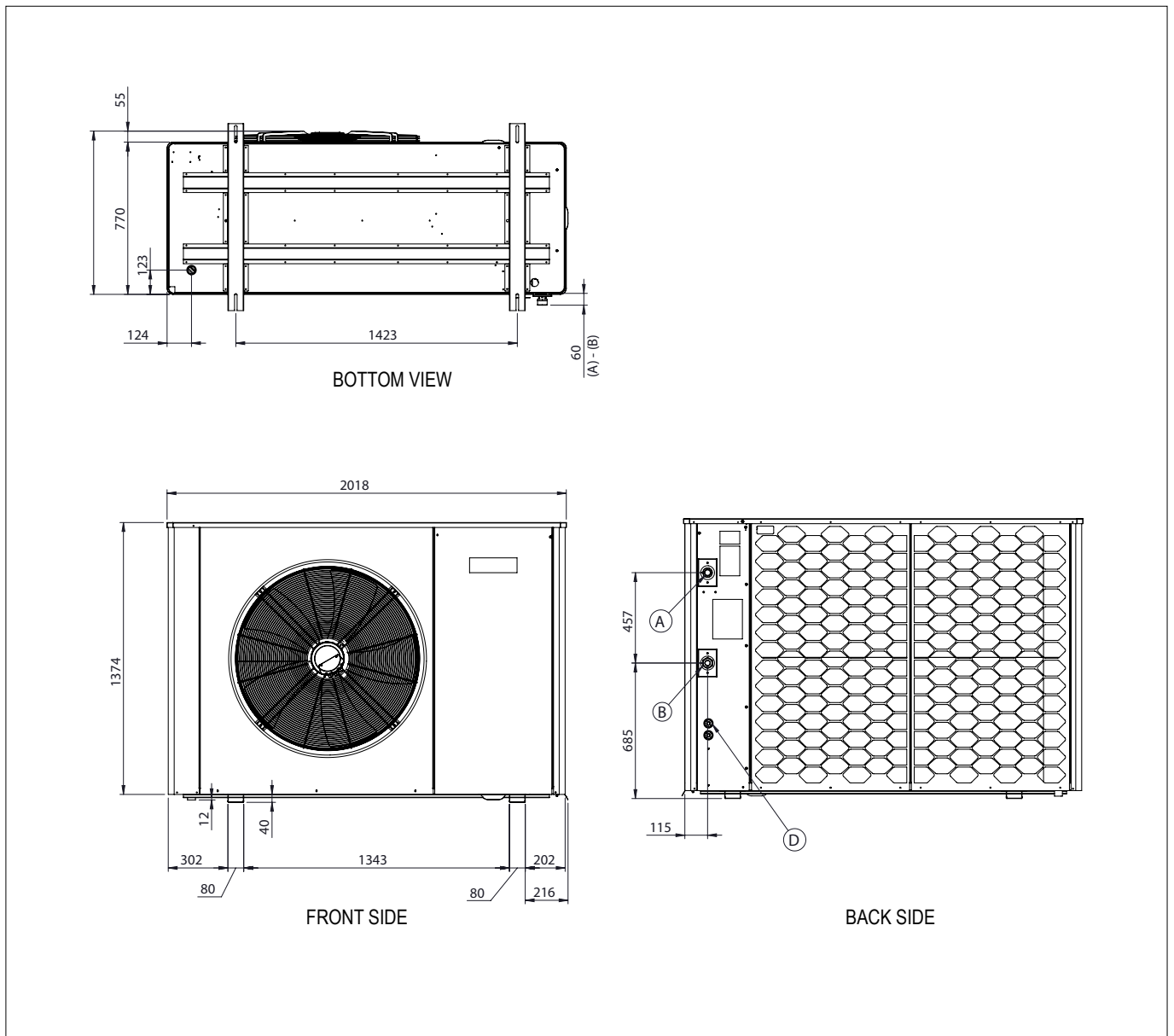
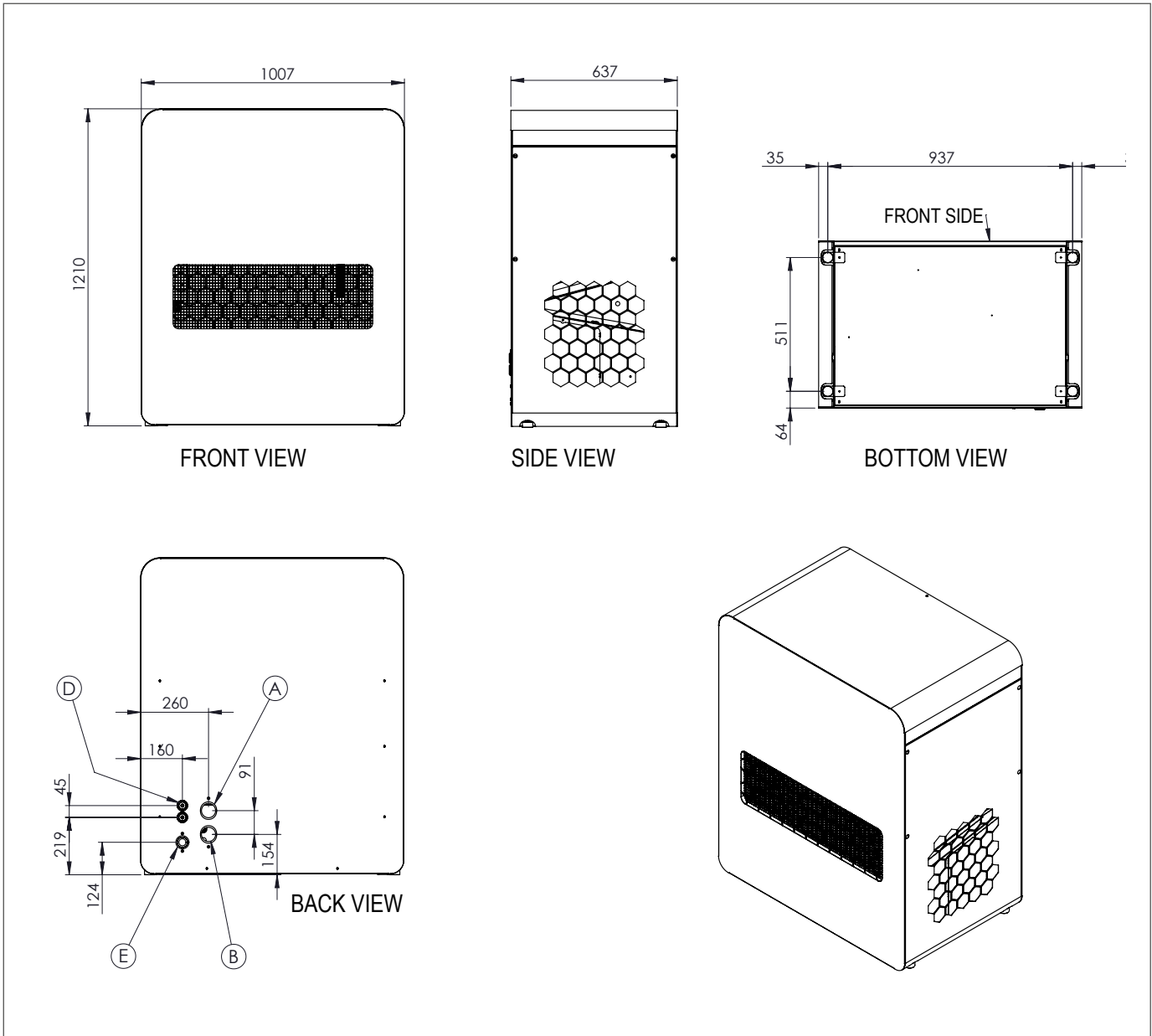

FIG. 5 (Dimensions of L-series - LP Plus - LR Plus - with brackets)

Ref.	
A	Water outlet connection - 1" 1/2
B	Water inlet connection - 1" 1/2
C	Condensate drain connection with external diameter \varnothing 40 mm
D	Electric cable gland

TAB. 11 (L-series - LP Plus - LR Plus connection dimensions)

5.5.5 XS-SERIES DIMENSIONS XS - X) - HIGH VERSION



Ref.	
A	Water inlet connection - 1" fitting
B	Water outlet connection - 1" fitting
E	Condensate drain connection with external diameter \varnothing 40 mm
D	Electric cable gland

5.5.6 XS-SERIES DIMENSIONS XS - X) - LOW VERSION

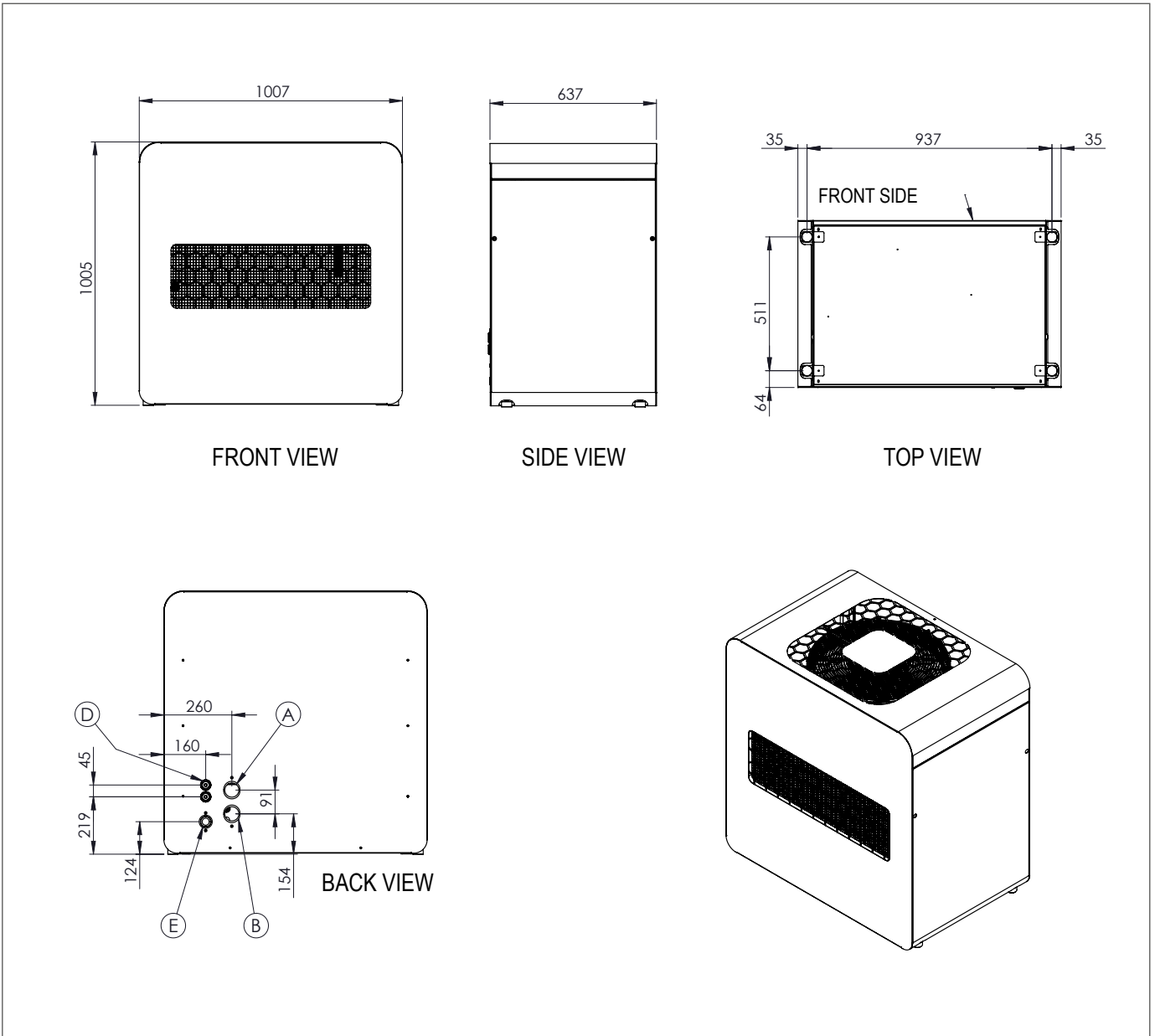

Ref.	
A	Water inlet connection - 1" fitting
B	Water outlet connection - 1" fitting
E	Condensate drain connection with external diameter \varnothing 40 mm
D	Electric cable gland

5.6 CIRCULATORS

The circulator shown in the table according to the series and the model is installed in the machine.

Series	Model	Internal circulator type	External circulator type
XS	XS-7,5	Grundfos UPM4K 15-75 130 PWM	
	XS-9		
	X-7,5		
	X-9		
HRP	HRP-10	Grundfos UPM4XL 25-90	
	HRP-12		
	HRP-14		
	HRP-16		
SP-T	SP-8T		Wilo Para 25/8 Grundfos UPM4XL 25-90
	SP-10T		
	SP-12T		
SP	SP-8		
	SP-10		
	SP-12		
MP	MP-14	Grundfos UPM4XL 25-90	
	MP-16		
	MP-18	Grundfos UPM4XL 25-90	
	MP-20		
LP	LP-22		Wilo Yonos Para HF 30/12 Templari GPA 32-17 H PRO 180 Grundfos UPM10XL 25-125 180 Templari GPA 25-13 H PRO 180
	LP-26		
	LP-28	Grundfos UPM10XL 25-125 180 Templari GPA 25-13 H PRO 180	
	LP-32		
	LP-35		
LP-Plus	LP Plus-35	Templari GPA 25-13 PRO 180	Wilo Yonos Para HF 30/12 Templari GPA 32-17 H PRO 180 Grundfos UPM10XL 25-125 180 Templari GPA 25-13 H PRO 180
	LP Plus-40		
LR	LR-35	Wilo Yonos Para HF 30/12 Templari GPA 32-17 H PRO 180	Wilo Yonos Para HF 30/12 Templari GPA 32-17 H PRO 180 Grundfos UPM10XL 25-125 180 Templari GPA 25-13 H PRO 180
	LR-35 Cold		
LR Plus	LR-Plus-45	Wilo Yonos Para HF 30/12 Templari GPA 32-17 H PRO 180	Wilo Yonos Para HF 30/12 Templari GPA 32-17 H PRO 180

TAB. 12 (Series - Model - Circulators)

5.7 LIMITS OF USE AND TECHNICAL DATA

Circulator Wilo Para 25/8 and Wilo Para R 25/8		
Power supply voltage	V AC	230
Power supply frequency	Hz	50 / 60
Energy efficiency index	EEI	≤0.21
MAX. power consumption	W	75
MAX. current consumption	A	0.66
MAX. head	m	8.4
MIN. inlet pressure	bar	0.5
Circulator Wilo Para 25/8 Plus and Wilo Para R 25/8 Plus		
Power supply voltage	V AC	230
Power supply frequency	Hz	50 / 60
Energy efficiency index	EEI	≤0.21
MAX. power consumption	W	87
MAX. current consumption	A	0.8
MAX. head	m	8
MIN. inlet pressure	bar	0.5
Circulator Wilo Para 25/9 and Wilo Para R 25/9		
Power supply voltage	V AC	230
Power supply frequency	Hz	50 / 60
Energy efficiency index	EEI	≤0.21
MAX. power consumption	W	87
MAX. current consumption	A	0.66
MAX. head	m	9
MIN. inlet pressure	bar	0.5
Circulator Wilo Para Maxo 25-180 e Wilo Para Maxo R 25-180		
Power supply voltage	V AC	230
Power supply frequency	Hz	50 / 60
Energy efficiency index	EEI	≤0.2
MAX. power consumption	W	195
MAX. current consumption	A	1.5
MAX. head	m	10.4
MIN. inlet pressure	bar	0.5

continued

Circulator Wilo Yonos Para HF 30/12		
Power supply voltage	VAC	230
Power supply frequency	Hz	50 / 60
Energy efficiency index	EEI	≤ 0.23
MAX. power consumption	W	305
MAX. current consumption	A	1.33
MAX. head	m	11
MIN. inlet pressure	bar	0.5
Circulator Templari GPA 32-17 H PRO 180		
Power supply voltage	VAC	220 - 240
Power supply frequency	Hz	50 / 60
Energy efficiency index	EEI	≤ 0,23
MAX. power consumption	W	350
MAX. current consumption	A	1,6
MAX. head	m	17
MIN. inlet pressure	bar	0,5
Circulator Grundfos UPM4XL 25-90		
Power supply voltage	VAC	230
Power supply frequency	Hz	50 / 60
Energy efficiency index	EEI	≤ 0.20
MAX. power consumption	W	92
MAX. current consumption	A	0.77
MAX. head	m	9.5
MIN. inlet pressure	bar	0.5
Circulator Grundfos UPMXL 25-125 180		
Power supply voltage	VAC	230
Power supply frequency	Hz	50 / 60
Energy efficiency index	EEI	≤ 0.23
MAX. power consumption	W	180
MAX. current consumption	A	1.42
MAX. head	m	12.8
MIN. inlet pressure	bar	0.1

continued

Circulator Grundfos UPM10XL 25-125 180			
Power supply voltage		V AC	230
Power supply frequency		Hz	50 / 60
Energy efficiency index		EEI	≤ 0.20
MAX. power consumption		W	100
MAX. current consumption		A	1.5
MAX. head		m	9.6
MIN. inlet pressure		bar	0.5
Circulator Templari GPA 25 -13 H PRO 180			
Power supply voltage		V AC	220 - 240
Power supply frequency		Hz	50 / 60
Energy efficiency index		EEI	≤ 0,23
MAX. power consumption		W	195
MAX. current consumption		A	1,3
MAX. head		m	13
MIN. inlet pressure		bar	0,3
Circulator Grundfos UPM4K 15-75 130 PWM			
Power supply voltage		V AC	230
Power supply frequency		Hz	50 / 60
Energy efficiency index		EEI	≤ 0,20
MAX. power consumption		W	63
MAX. current consumption		A	0,57
MAX. head		m	7,5
MIN. inlet pressure		bar	0,5
Production temperatures			
MIN. - MAX. cooling temperature		°C	5 - 25
MIN. - MAX. heating temperature	R290	°C	10 - 65
	R32	°C	10 - 55
MIN. - MAX. domestic hot water temperature	R290	°C	35 - 65
	R32	°C	35 - 55
Safety pressure switch trip with refrigerant gas	R290	MPa / bar	2,93 / 29,3
	R32	MPa / bar	4,25 / 42,5

continued

Recommended values for water		
Water acidity	PH	6 ÷ 8
Electrical conductivity	mV/cm	<220 (25°)
Chlorine ions	ppm	<50
Sulphuric acid ions	ppm	<50
Total iron	ppm	<0.3
M Alkalinity	ppm	<50
Total hardness	ppm	<50 (5° F)
Sulphur ions		None
Ammonia ions		None
Silicon ions	ppm	30
Ambient limits		
MIN. / MAX. ambient temperature (with R290 refrigerant)	°C	-22 ÷ 46
MIN. / MAX. ambient temperature (with R32 refrigerant)	°C	-25 ÷ 46
MAX. relative humidity	%	90
MAX. altitude	m a.s.l.	2000

TAB. 13 (Limits of use and technical data)

5.8 FLOW RATE MIN. FLOW THRESHOLD

TAB. 14 shows the MIN. flow and the consequent error threshold for each model of monoblock heat pump.

Series	Model	Flowmeter			Value
		Alarm threshold range (litres/min)	Recommended minimum flow rate (litres/min)	Nominal flow rate A7/W35 DT=SK (litres/min)	
XS	XS-7,5	18	21,5	21,5	DN20
	XS-9	18	21,5	25,8	
	X-7,5	18	21,5	21,5	
	X-9	18	21,5	25,8	
HRP	HRP-10	25	30	29	DN25
	HRP-12	25	30	34	
	HRP-14	25	30	40	
	HRP-16	25	30	46	
SP-T	SP-8T	25	30	23	
	SP-10T	25	30	29	
	SP-12T	25	30	34	
SP	SP-8	25	30	23	
	SP-10	25	30	29	
	SP-12	25	30	34	
MP	MP-14	25	35	40	
	MP-16	25	40	46	
	MP-18	30	45	52	
	MP-20	30	50	57	
LP	LP-22	34	54	63	
	LP-26	34	57	75	
	LP-28	46	70	80	
	LP-32	50	75	92	
	LP-35	54	80	100	
LP-Plus	LP Plus-35	70	90	100	
	LP Plus-40	70	100	115	
LR	LR-35	54	80	100	
	LR-35 Cold	54	80	100	
LR Plus	LR Plus-45	70	100	129	

TAB. 14 (Flow rate MIN. flow threshold)

5.9 PERMITTED OPERATING AREA

5.9.1 HEATING AND COOLING MODES FOR SP-T SERIES

For models SP-8T - SP-10T - SP-12T

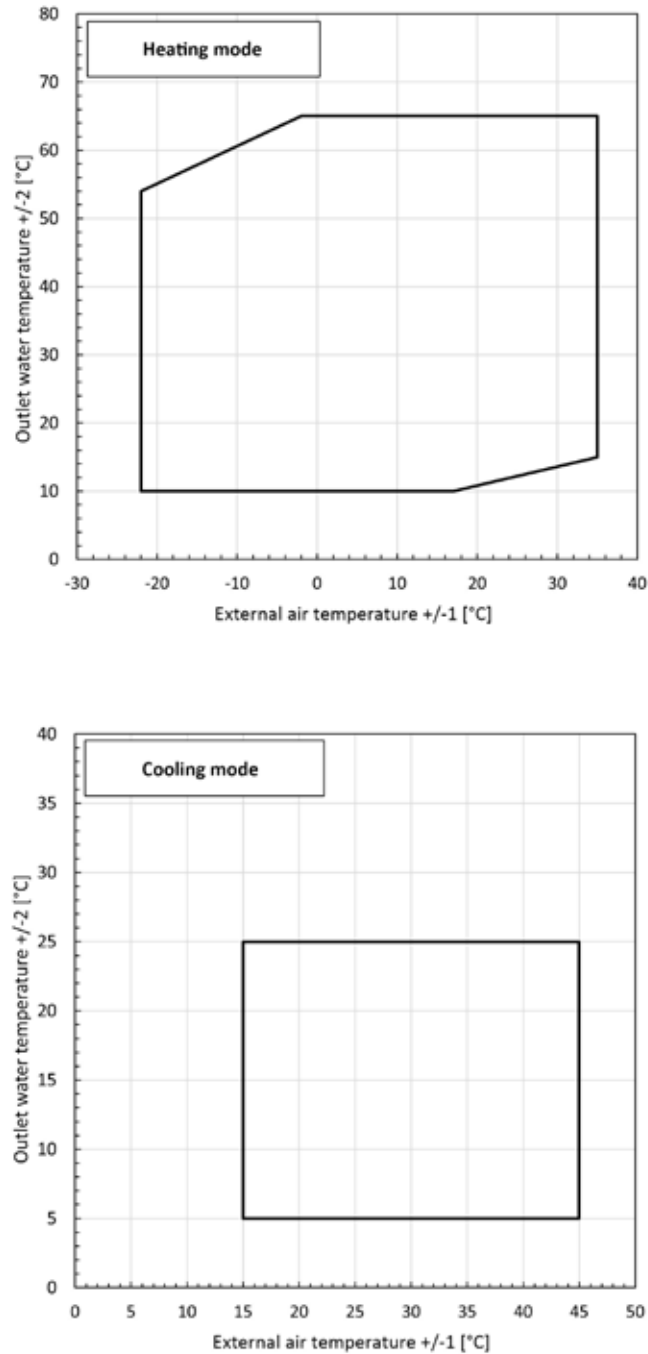

FIG. 6 (Heating and cooling modes for SP-T Series)

5.9.2 HEATING AND COOLING MODES FOR MP - LP SERIES

For models MP-18 - MP-20 - LP-22

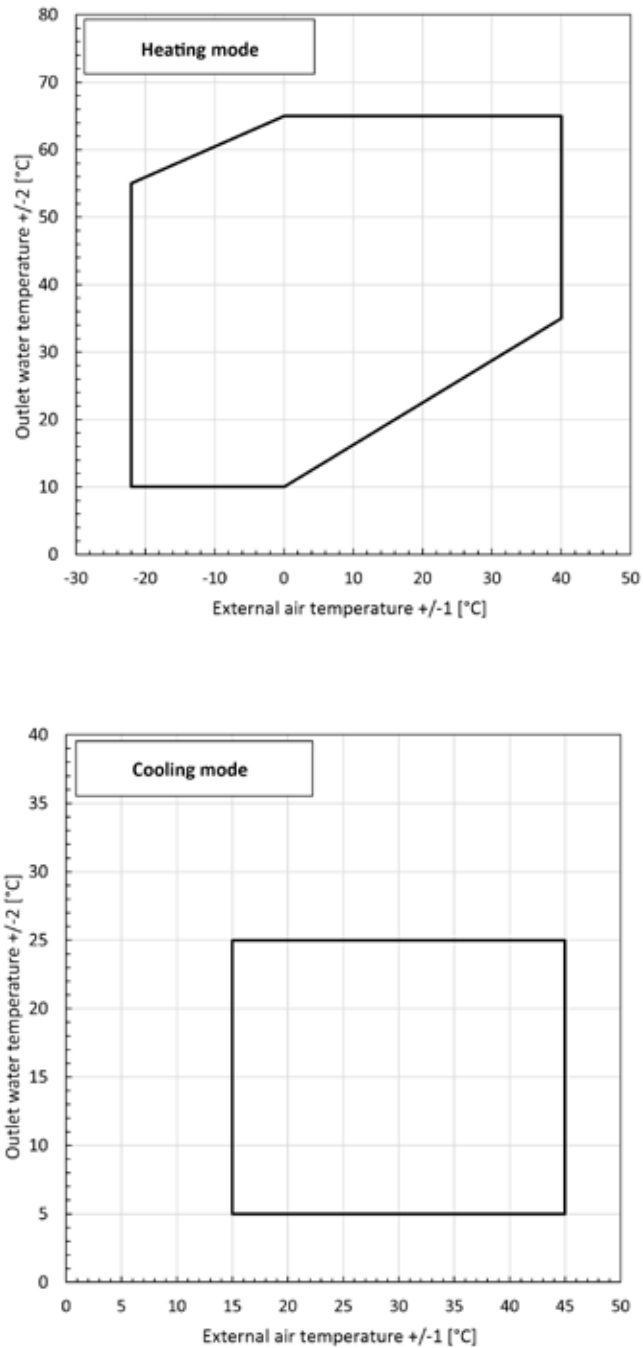

FIG. 7 (Heating and cooling modes for MP - LP Series)

5.9.3 HEATING AND COOLING MODES FOR SP - MP - LP - LP PLUS SERIES

For models SP-8 - SP-10 - SP-12 - MP-14 - MP-16 - LP-26 - LP-28 - LP-32 - LP-35 - LP Plus-35 - LP Plus-4

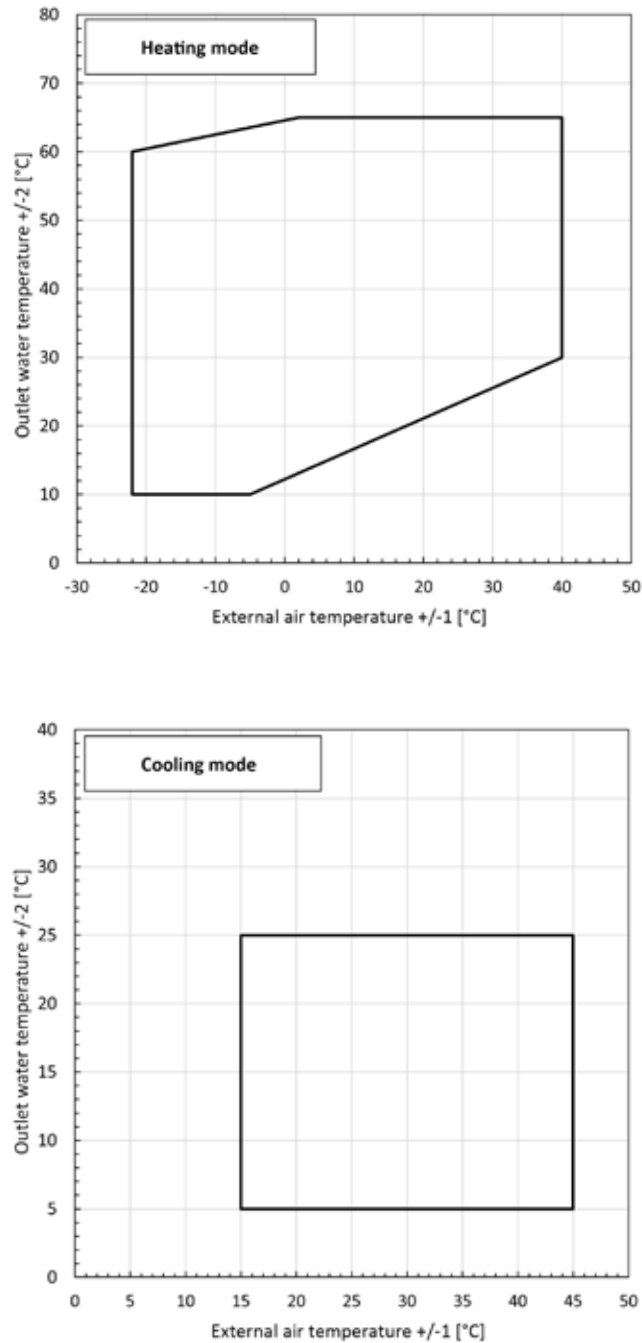

FIG. 8 (Heating and cooling modes for SP - MP - LP - LP Plus Series)

5.9.4 HEATING AND COOLING MODES FOR LR - LR PLUS SERIES

For models LR-35 - LR-35 Cold - LR Plus-45

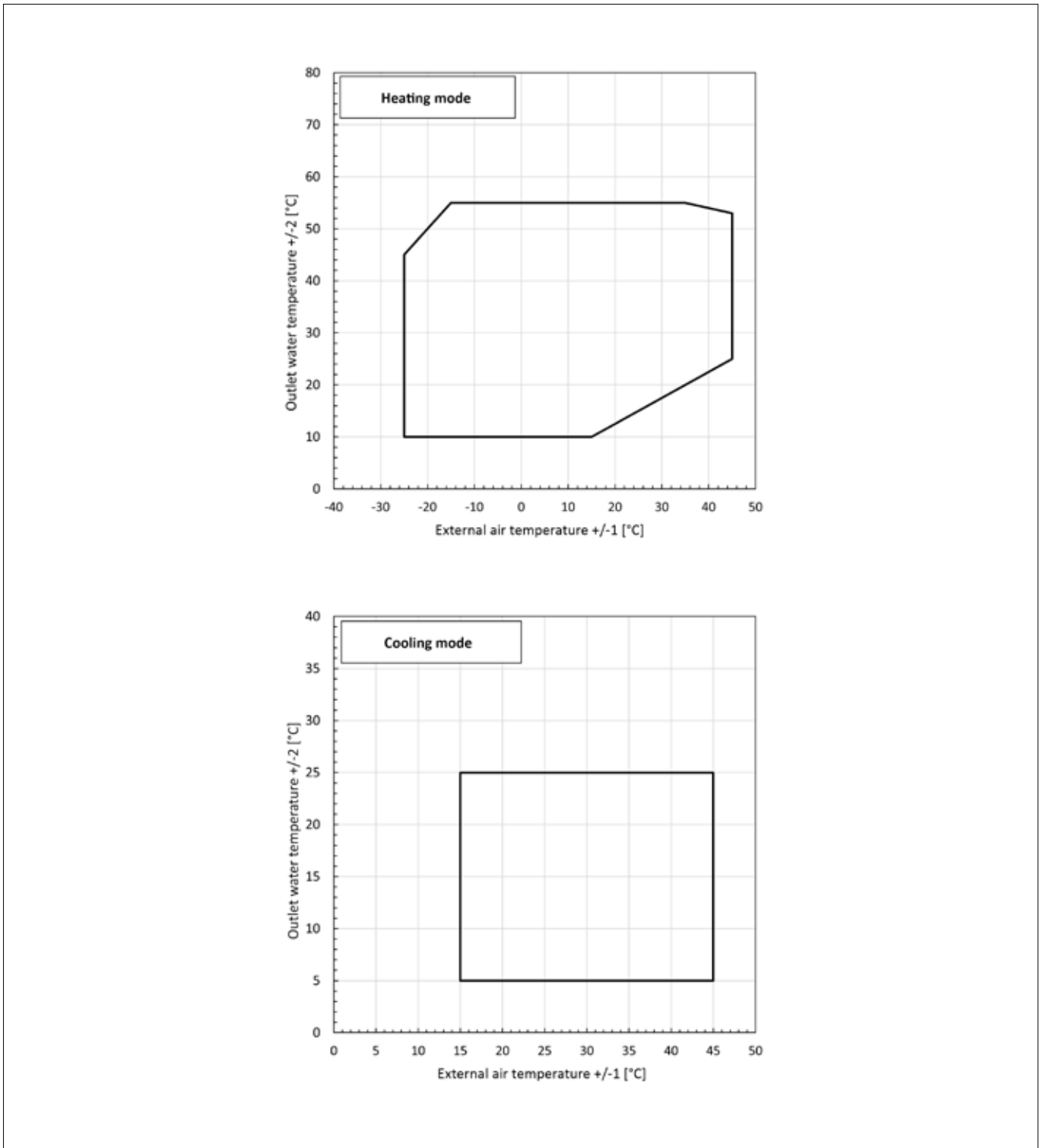

FIG. 9 (Heating and cooling modes for LR - LR Plus Series)

5.9.5 HEATING AND COOLING MODES FOR XS-X SERIES

For models XS-7,5 - XS-9 - X-7,5 - X-9

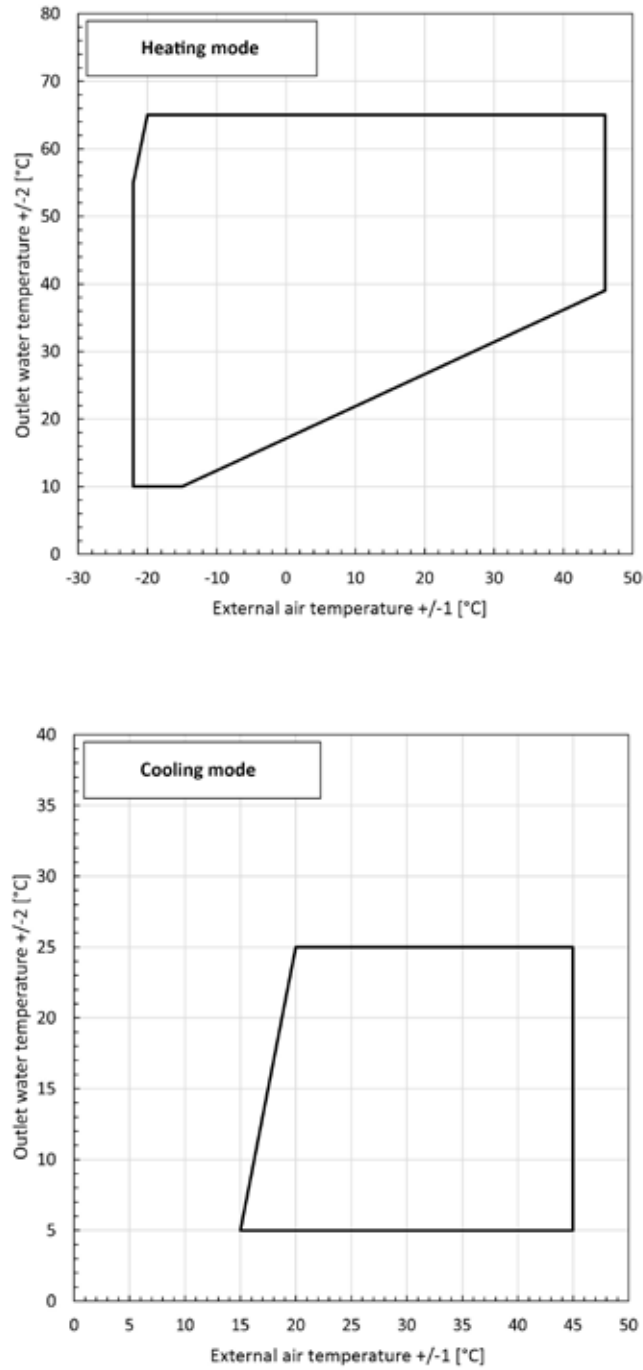

FIG. 10(Heating and cooling modes for XS - X Series)

5.10 CHARACTERISTIC CURVES OF CIRCULATORS

5.10.1 CIRCULATOR WILO PARA 25/8

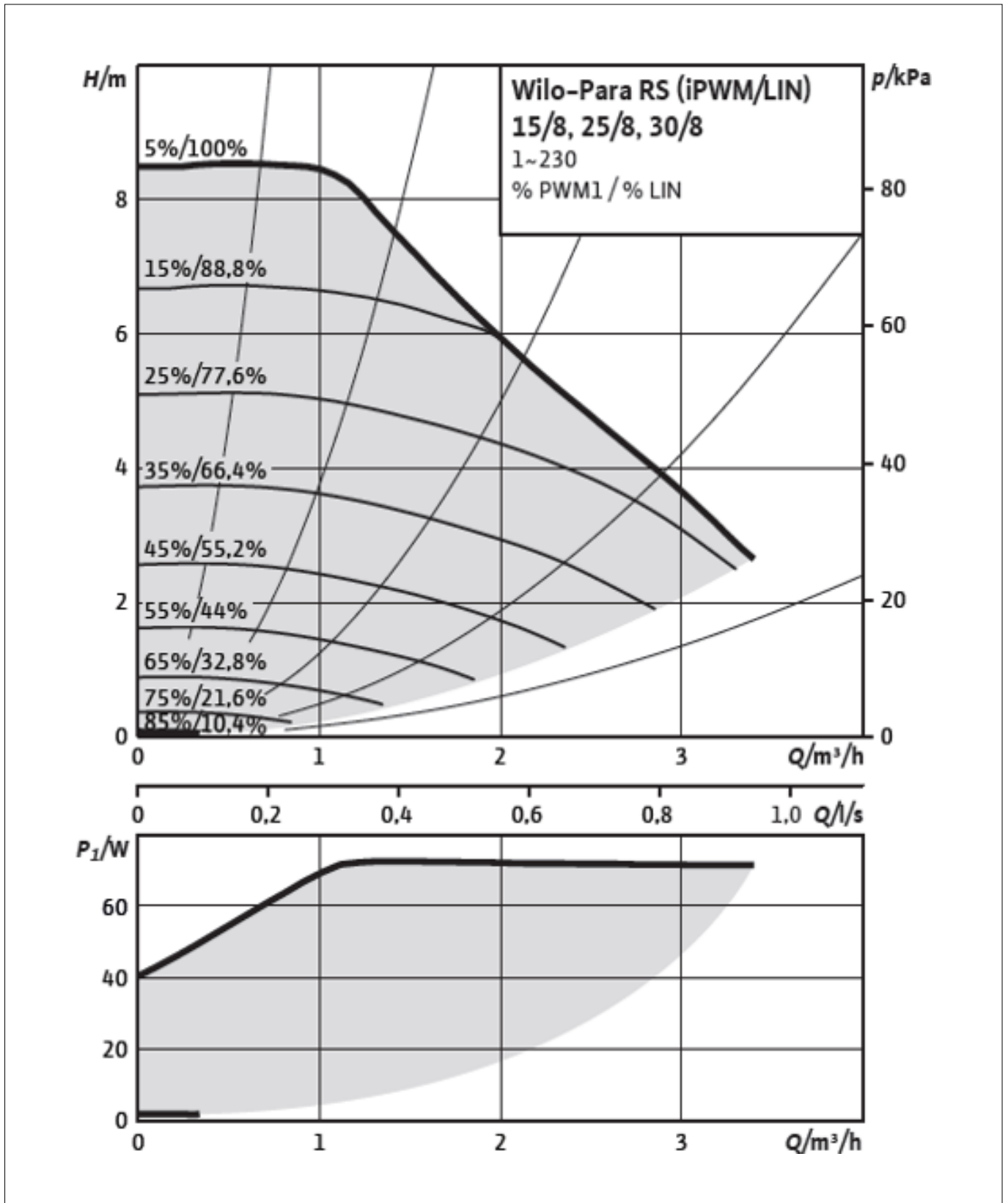

FIG. 11 (Curves and characteristics of circulator type Wilo Para 25/8)

5.10.2 CIRCULATOR WILO PARA 25/8 PLUS

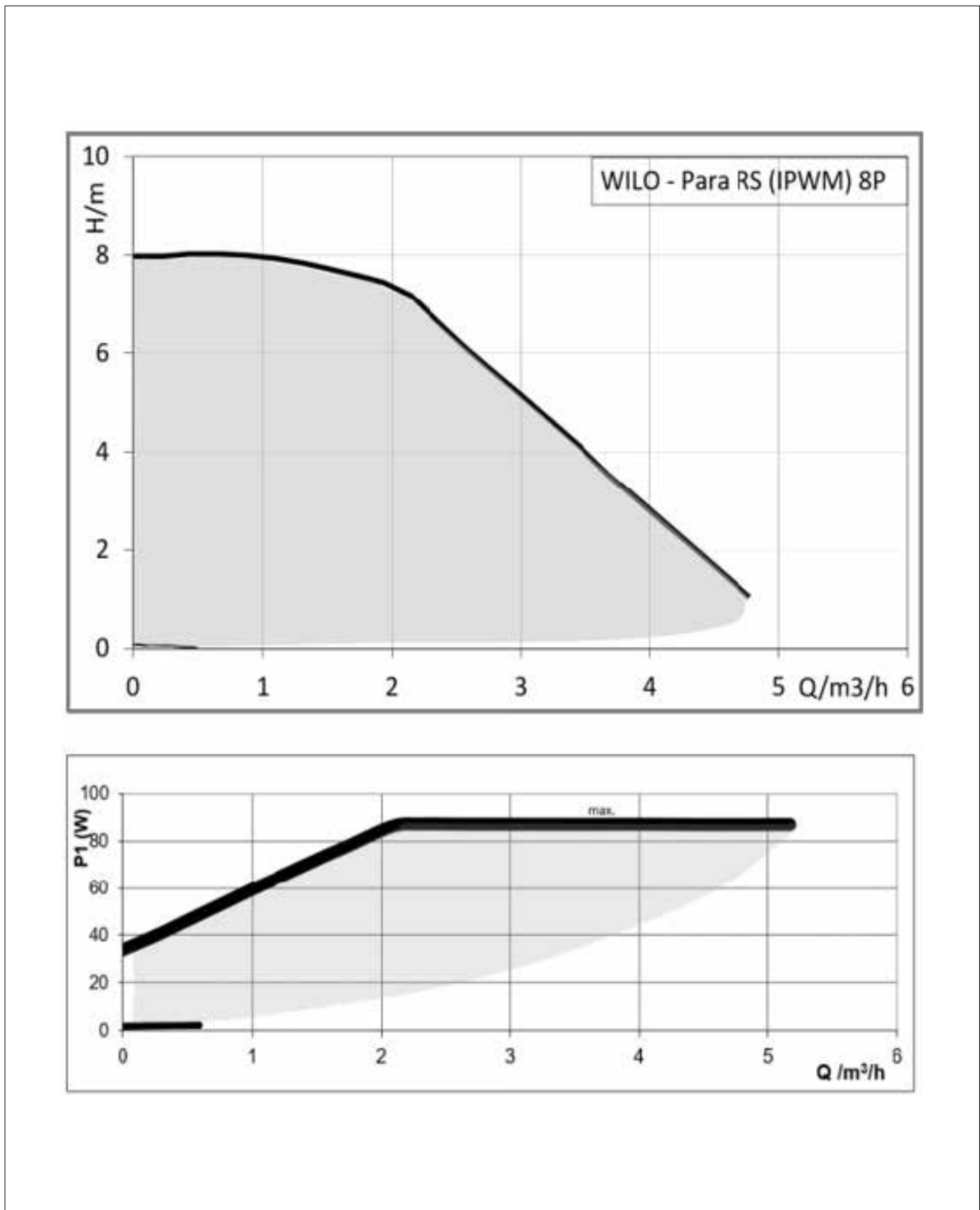

FIG. 12 (Curves and characteristics of circulator type Wilo Para 25/8 Plus)

5.10.3 CIRCULATOR WILO PARA 25/9

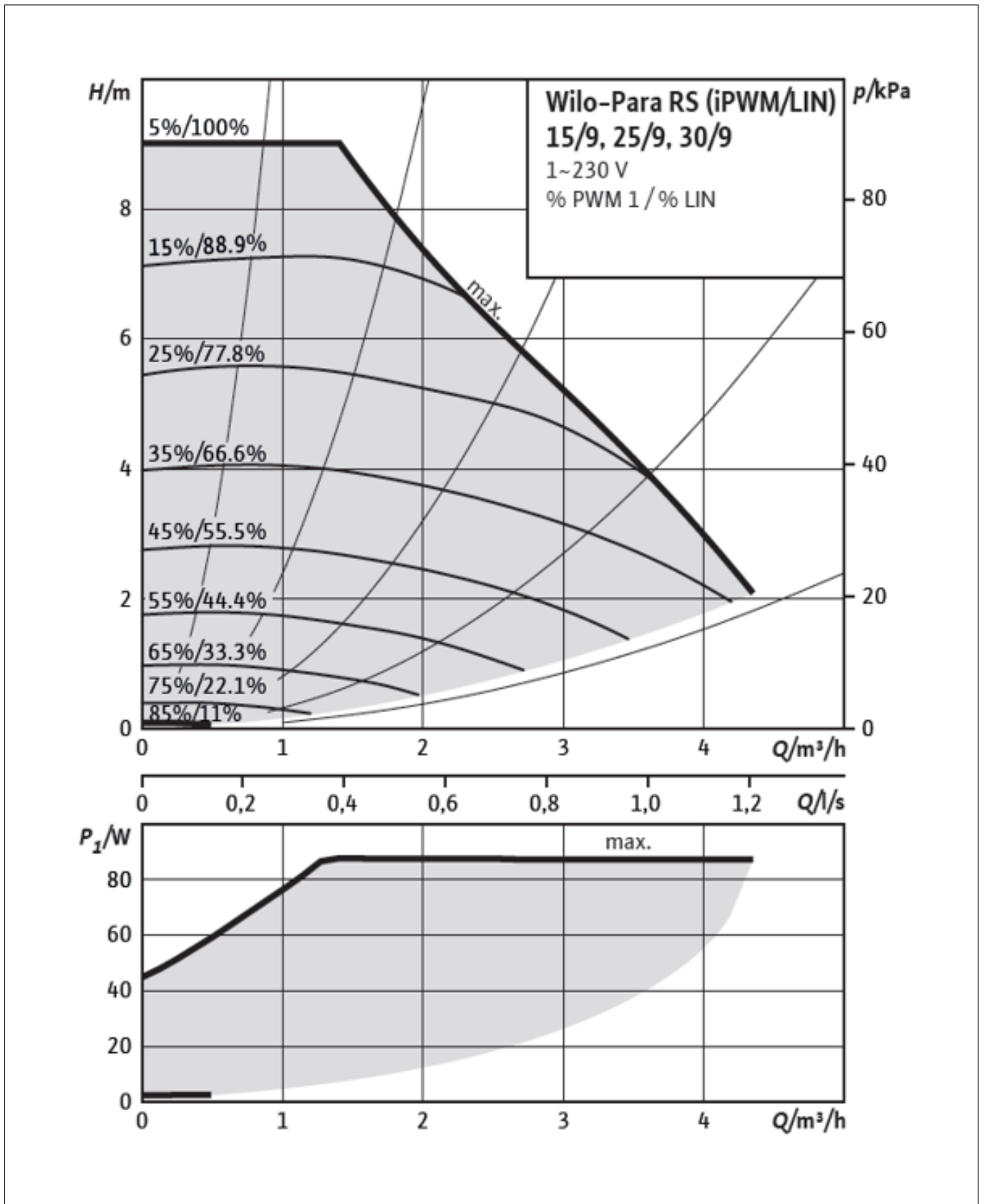

FIG. 13 (Curves and characteristics of circulator type Wilo Para 25/9)

5.10.4 CIRCULATOR WILO YONOS PARA HF 30/12

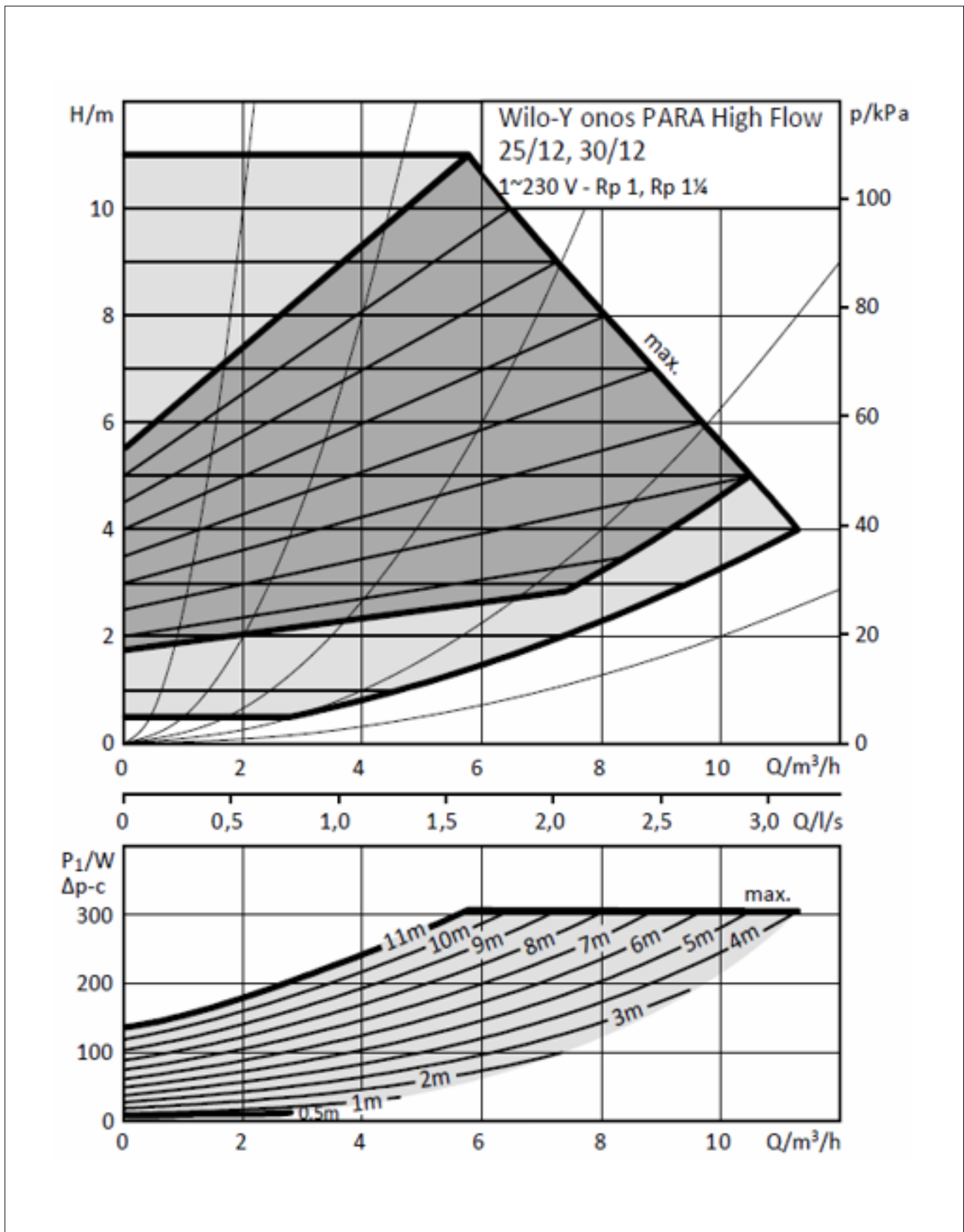

FIG. 14 (Curves and characteristics of circulator type Wilo Yonos Para HF 30/12)

5.10.5 CIRCULATOR TEMPLARI GPA 32-17 H PRO/180

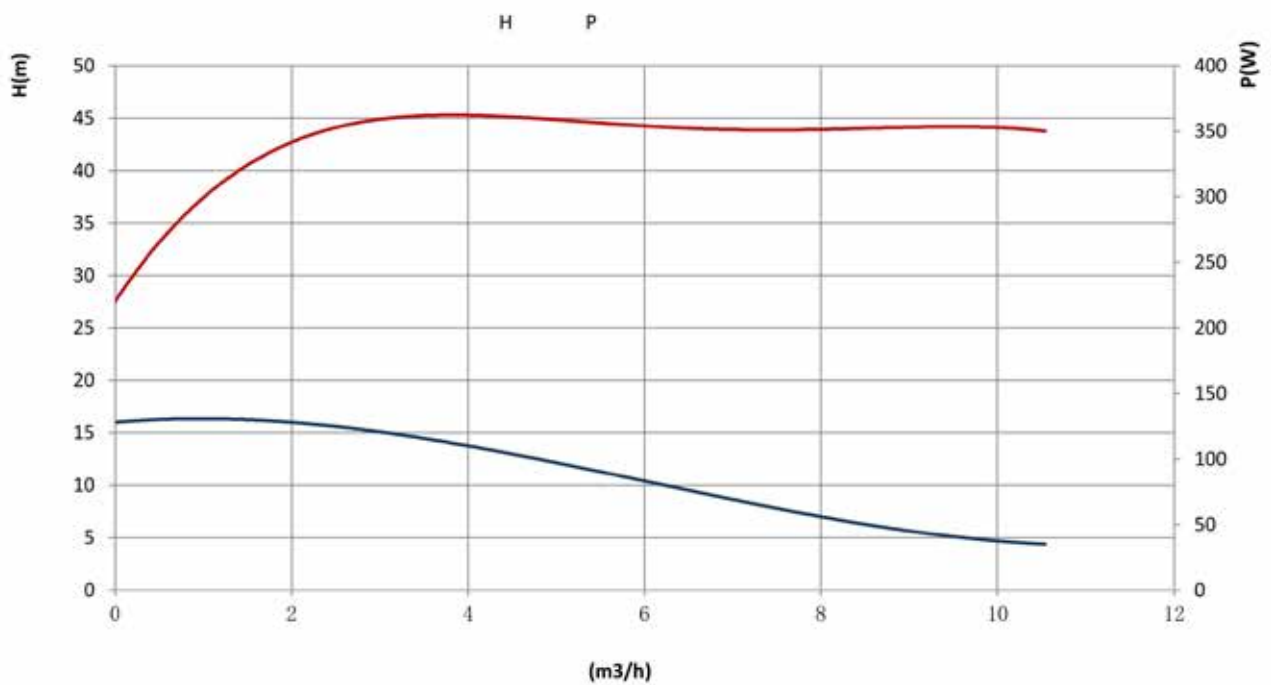

FIG. 15 (Curves and characteristics of circulator type Templari Gra 32-17 H Pro/180)

5.10.6 CIRCULATOR GRUNDFOS UPM4XL 25-90

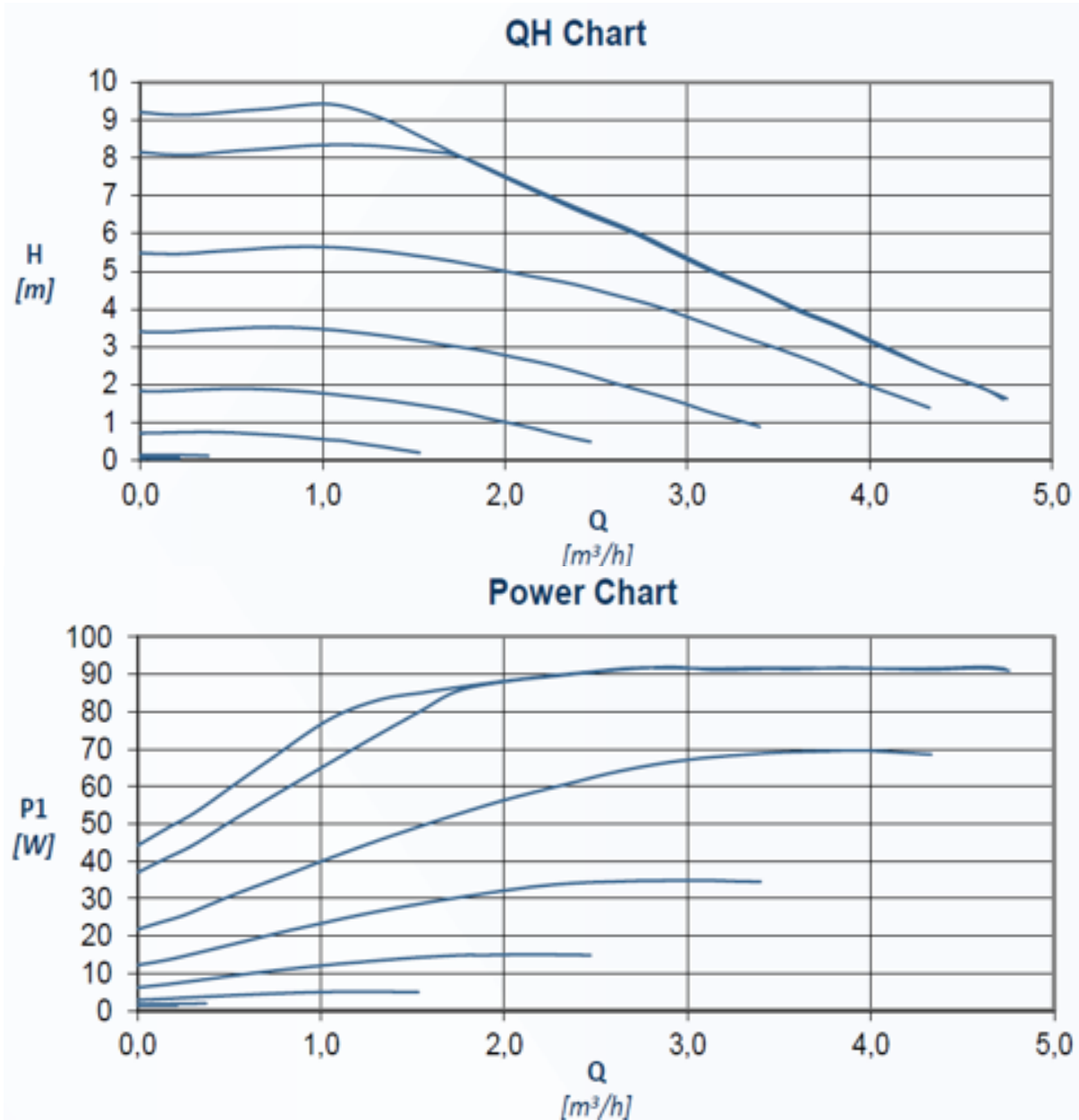

FIG. 16 (Curves and characteristics of circulator type Grundfos UPM4XL 25-90)

5.10.7 CIRCULATOR GRUNDFOS UPMXL 25-125 180

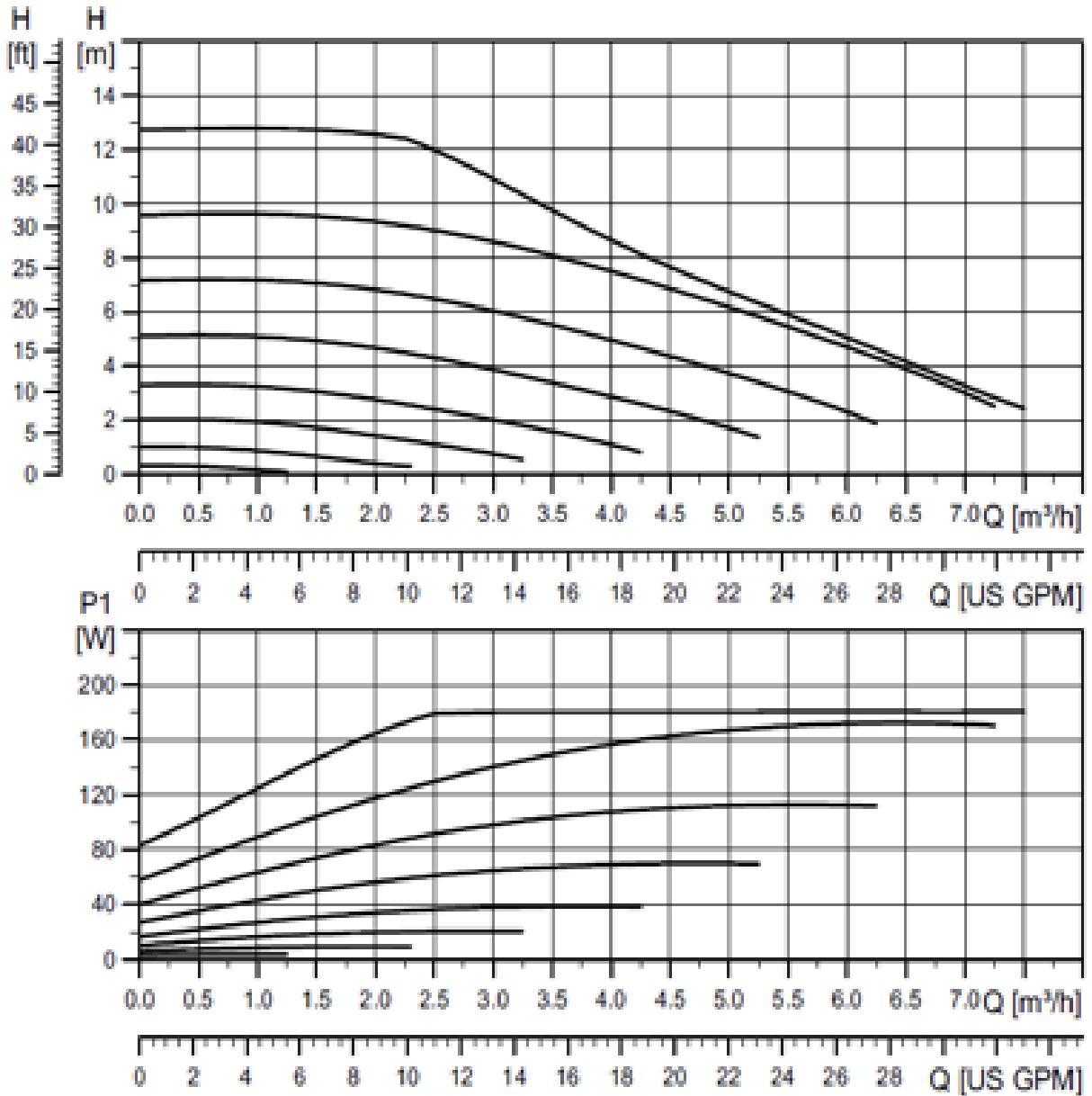

FIG. 17 (Curves and characteristics of circulator type Grundfos UPMXL 25-125 180)

5.10.8 CIRCULATOR GRUNDFOS UPM10XL 25-125 180

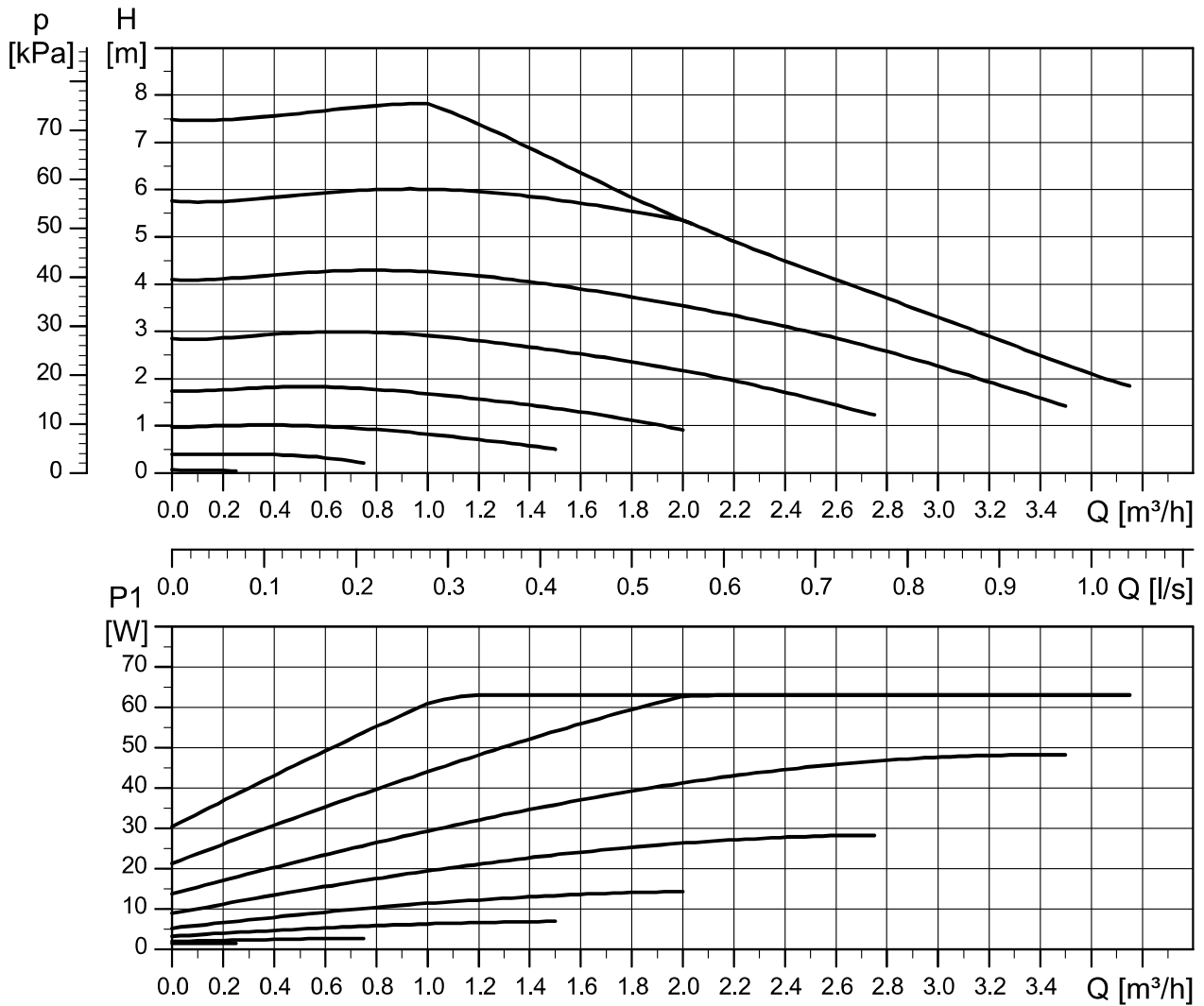

FIG. 18 (Curves and characteristics of circulator type Grundfos UPM10XL 25-125 180)

5.10.9 CIRCULATOR TEMPLARI GPA 25-13 H PRO/180W

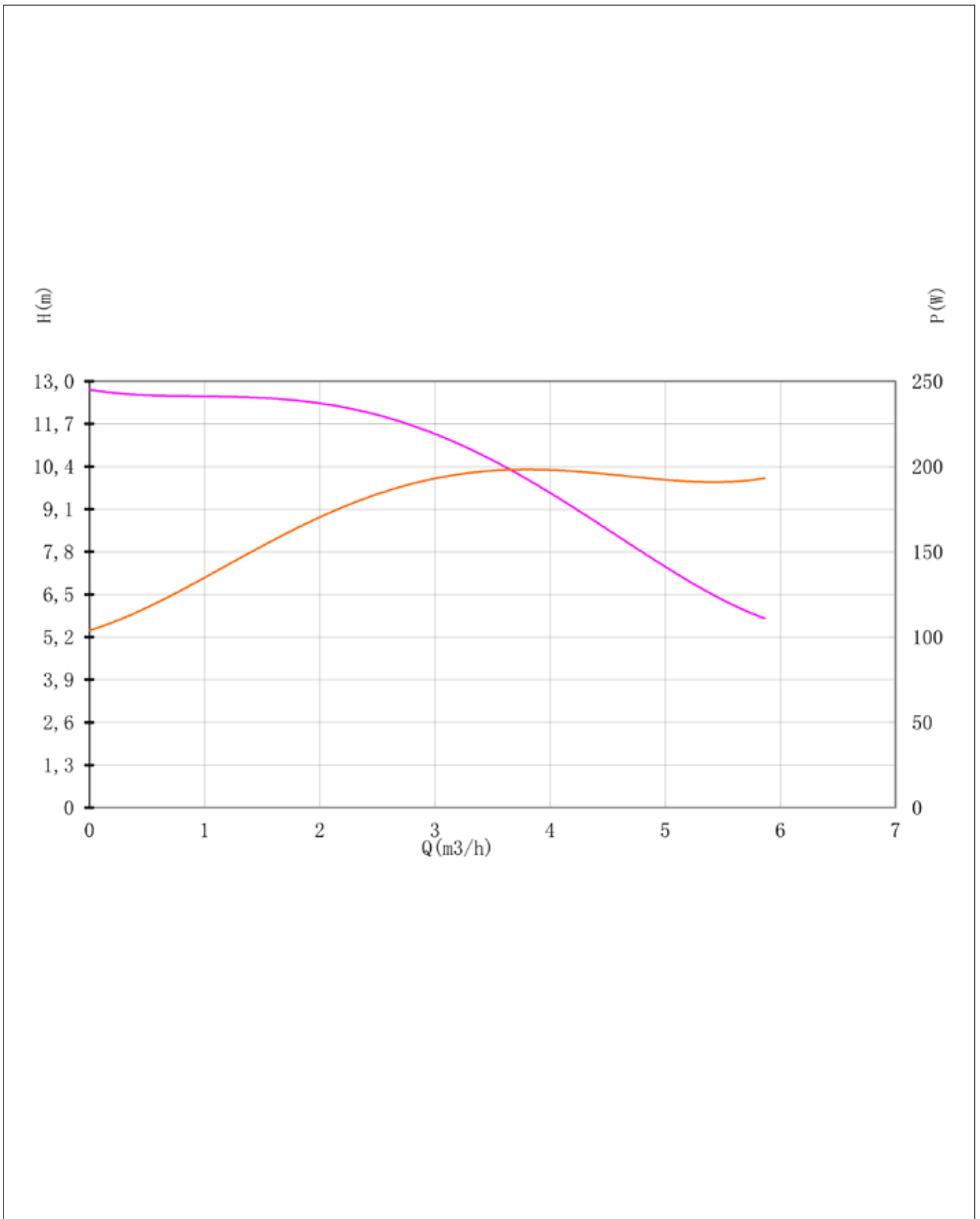

FIG. 19 (Curves and characteristics of circulator typ Templari GPA 25-13 H PRO/180)

5.10.10 CIRCULATOR GRUNDFOS UPM4K 15-75 130 PWM

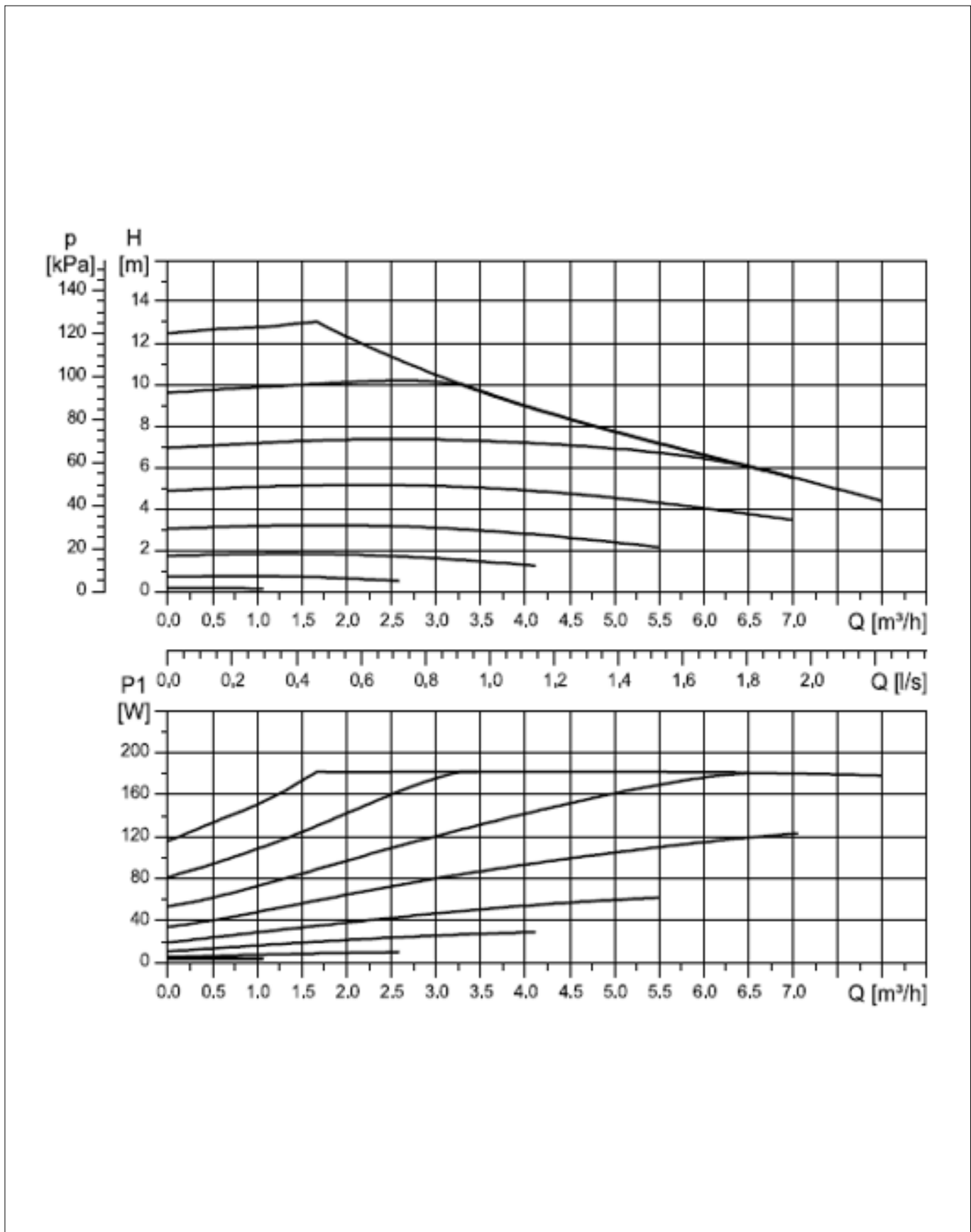

FIG. 20 (Curves and characteristics of circulator type Grundfos UPM10XL 25-125 180)

5.10.11 RESIDUAL HEAD

The residual head available for the hydraulic circuit corresponds to the circulator head appropriately reduced for the pressure drops in the stretch of hydraulic circuit affected by the machine components.

The following diagram shows the total pressure drops of the following components for the various models:

- plate heat exchanger
- deaerator
- flowmeter

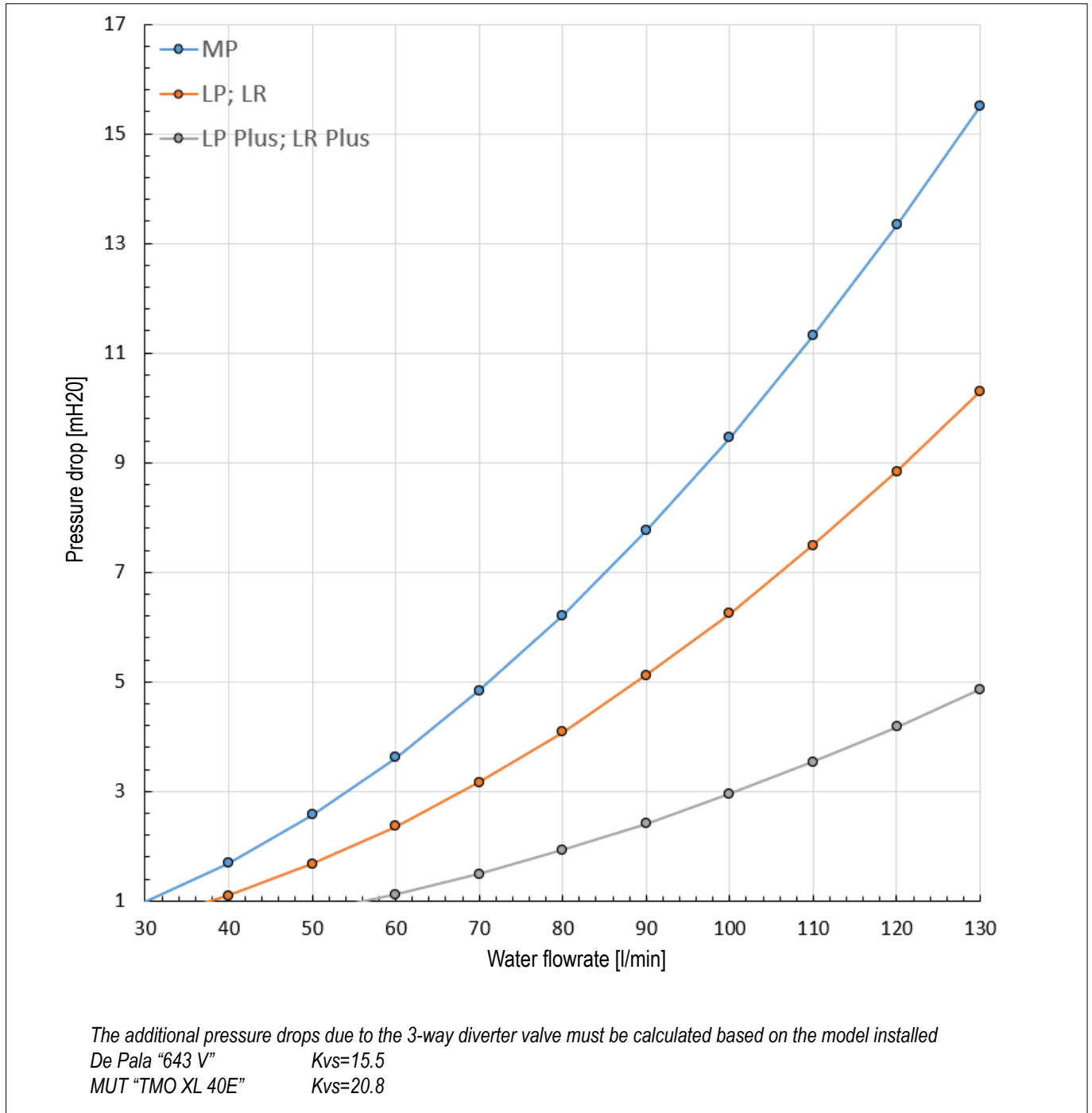
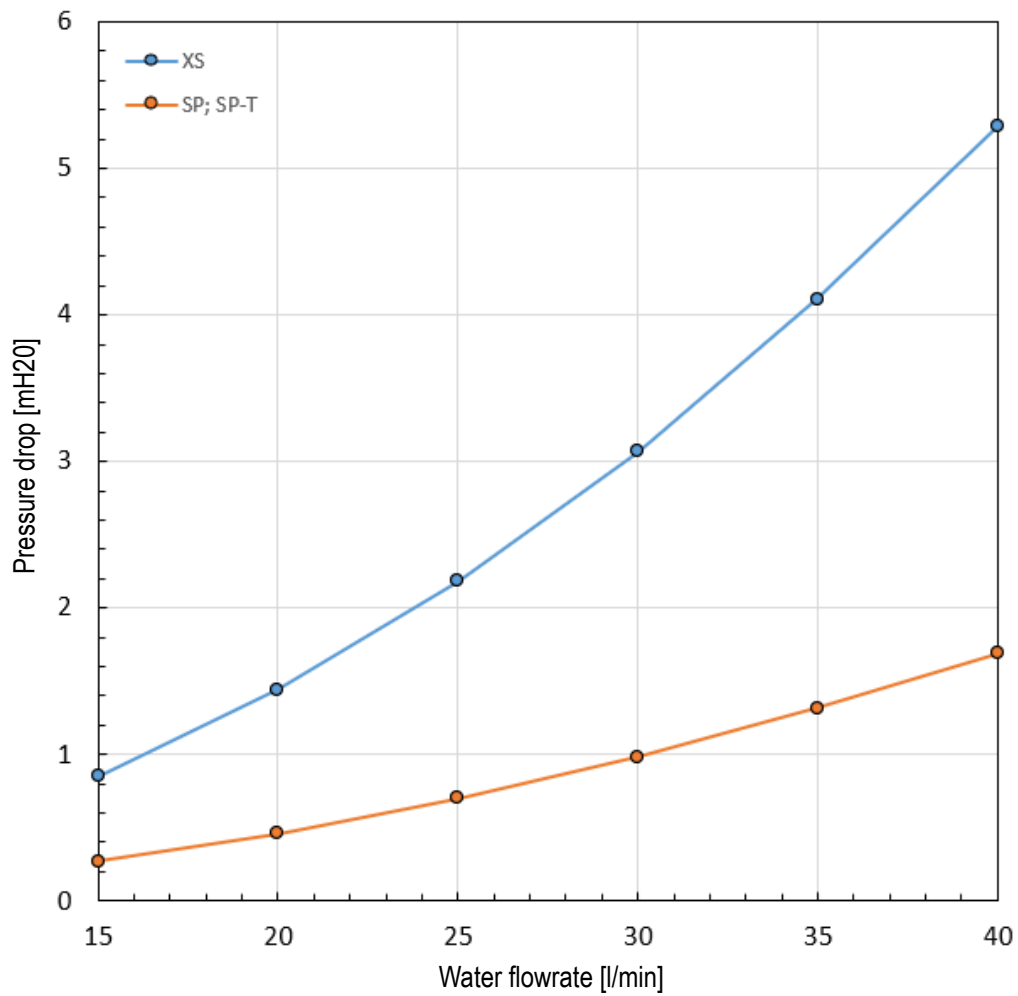

FIG. 21 (Residual heads)



The additional pressure drops due to the 3-way diverter valve must be calculated based on the model installed
 De Pala "643 V" $Kvs=15.5$
 MUT "TMO XL 40E" $Kvs=20.8$

FIG. 22(Pressure drop models XS, SP and SP-T)

5.11 OPERATING MODES

The heat pump can operate in two modes, which can be implemented by switching the 4-way valve: as illustrated below, these modes are heating and cooling/defrosting.

It is also possible to insert a suitable DHW (domestic hot water) management module consisting of relays, temperature sensors and 3-way valve. With this system, the pump is able to manage domestic hot water both in summer and winter as a priority.

5.11.1 HEATING

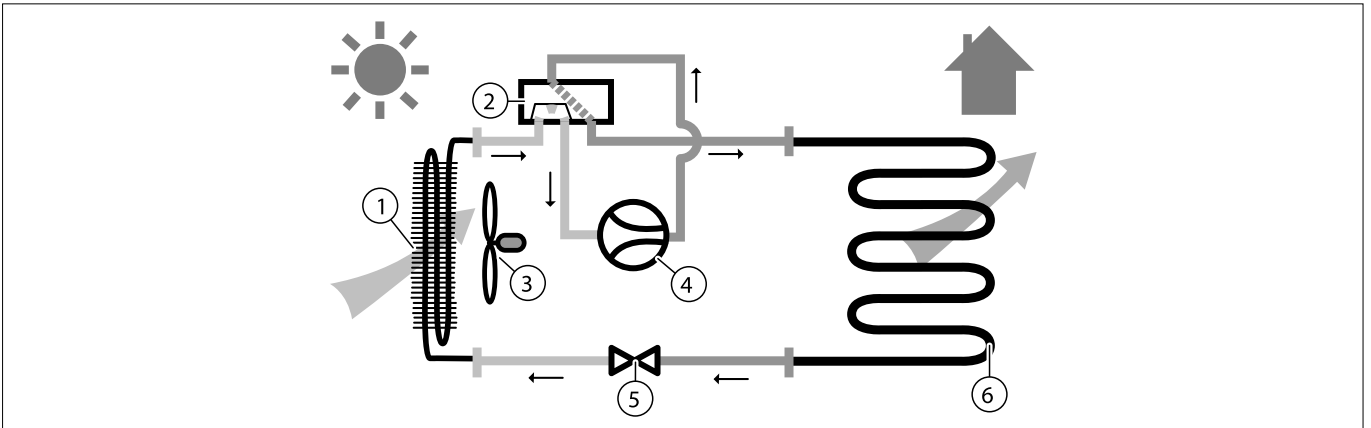

FIG. 23 (Heating mode)

Ref.		Ref.	
1	Evaporator	4	Compressor
2	4-way valve	5	Electronic expansion valve.
3	Fan	6	Plate heat exchanger

TAB. 15 (Components for heating mode)

5.11.2 COOLING OR DEFROSTING

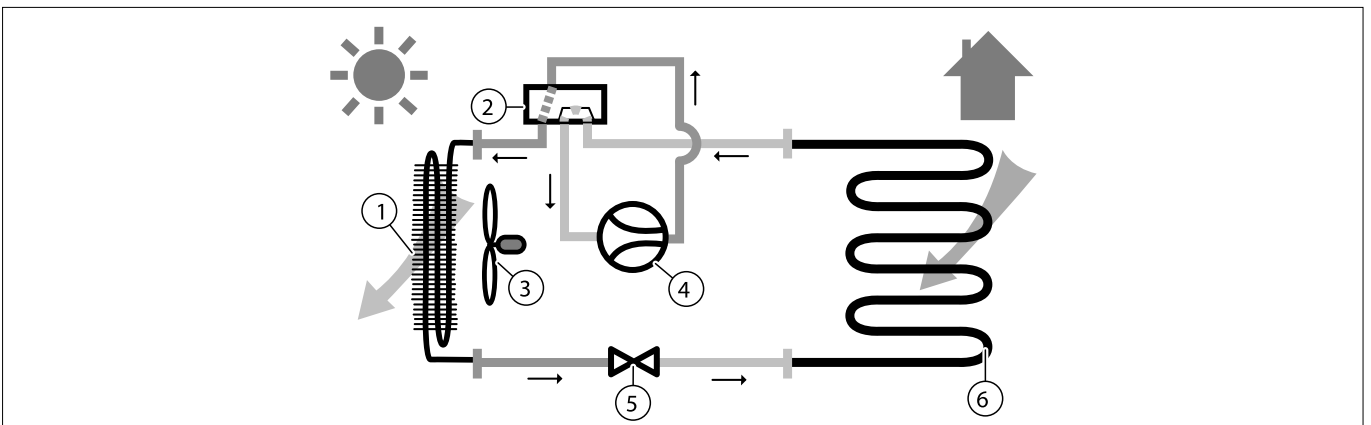

FIG. 24 (Cooling or defrosting mode)

Ref.		Ref.	
1	Evaporator	4	Compressor
2	4-way valve	5	Electronic expansion valve.
3	Fan	6	Plate heat exchanger

TAB. 16 (Components for cooling or defrosting mode)

5.12 STRUCTURE OF SYSTEM WITH HEAT PUMP

The heat pump system includes the following components:

- 1) Monoblock heat pump
- 2) Remote control
- 3) Optional hydraulic components, which can be requested from the Manufacturer:
 - Heating element for condensate drain
 - 3-way valve for combined management of the system and domestic hot water
 - mains filter
 - switching relay for operation with integration boiler



INFORMATION

THE MACHINE FUNCTIONS ARE FULLY CONTROLLED VIA THE REMOTE CONTROL.

5.13 ENERGY SUPPLY SOURCES

The machine is powered by the following energy sources:

EXTERNAL: Three-phase electrical supply **230 V - 50 Hz (1 ph)** o **400 V - 50 Hz (3 ph)**

5.14 EMISSIONS

5.14.1 AIRBORNE NOISE

The A-weighted emission sound pressure level at workstations (LpA) does not exceed **dB(A) <70**

5.15 PRODUCTS USED

The product used in the machine is a refrigerant gas **R32** GWP 675 or **R290** GWP 3 (GWP = global warming potential).

⚠ WARNING



THE AUTHORISED OPERATORS MUST READ THE SAFETY DATASHEETS SUPPLIED BY THE PRODUCERS OF SUCH PRODUCTS AND ENSURE THEY HAVE A FULL UNDERSTANDING OF THEIR CONTENTS.

ALL ACTIVITIES REQUIRING THE OPENING OF THE APPLIANCE CAN ONLY BE CARRIED OUT BY QUALIFIED PERSONS WHO ARE AWARE OF THE SPECIAL PROPERTIES AND HAZARDS OF R290 REFRIGERANT.

⚠ DANGER



THIS PRODUCT CONTAINS FLUORINATED GREENHOUSE GASES INCLUDED IN THE KYOTO PROTOCOL.

DO NOT RELEASE THESE GASES INTO THE ATMOSPHERE. THE REFRIGERANT IS EASILY FLAMMABLE, IN SAFETY GROUP A3 ACCORDING TO ISO 817 AND ANSI/ASHRAE 34.

5.16 DESIGNATION OF THE MAIN COMPONENTS

5.16.1 DESIGNATION OF THE MAIN COMPONENTS (EXAMPLE MODEL SP-8T)

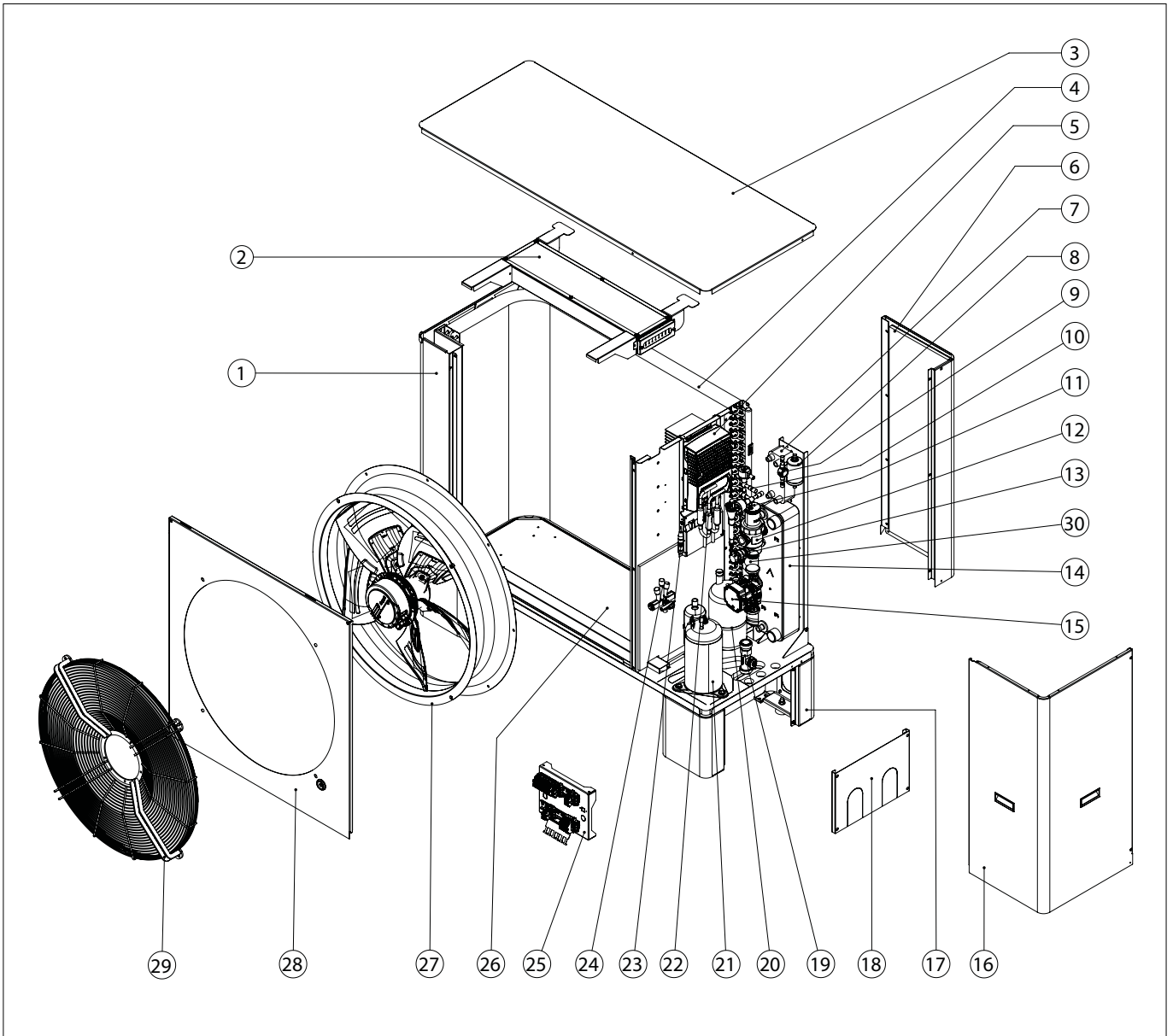

FIG. 25 (Designation of the main components - Example model SP-8T)

Ref.	Designation	Main functions
1	Frame	Contains the components
2	Main electrical panel (control)	Contains the electrical components for machine control
3	Top panel	Protects internal components
4	Evaporator	Allows heat exchange between external air and refrigerant gas (gas circuit)
5	Inverter	Allows the number of revolutions of the machine to be modulated

continued

Ref.	Designation	Main functions
6	Rear panel	Protects internal components
7	Economizer	Improves the efficiency of the refrigeration cycle
8	Dehydrator filter	Adsorbs humidity and filters acids and solid contaminants from refrigerant gas
9	Liquid indicator	Indicates the humidity downstream of the dehydrator filter (electronic expansion valve inlet).
10	Electronic expansion valve.	Performs refrigerant gas lamination (pressure reduction)
11	Venting valve	Vents any air or refrigerant gas present in the water (hydraulic circuit).
12	Deaerator	Extracts any air or refrigerant gas present in the water (hydraulic circuit).
13	Pressure relief valve	Protects the hydraulic circuit from overpressure. Calibrated to 2.5 bar
14	Plate heat exchanger	Allows heat exchange of refrigerant gas/water (hydraulic circuit)
15	Circulation pump (if internal)	Pumps water (hydraulic circuit)
16	Side panel	Protects internal components
17	Legs (if provided)	Support the machine
18	Leg closure panel	Protects internal components of legs
19	Flowmeter	Measures water flow rate (hydraulic circuit)
20	Liquid receiver	Compensates for the charge difference between chiller and heat pump operation
21	Compressor	Compresses the gas to allow it to flow into the gas circuit
22	Check valves	They force the gas to follow a predetermined path
23	Pressure switch	Calibration with refrigerant R290: 29.3 bar, with refrigerant R32: 42.8 bar
24	4-way valve	Allows the refrigerant gas flow to be reversed from summer operation (cooling) to winter operation (heating)
25	Secondary electrical panel (power supply)	Contains the main electrical components for the electrical panel power supply
26	Base	Supports the components
27	Fan	Conveys external air to allow air/refrigerant gas exchange on the evaporator
28	Fan panel	Allows the fan to be mounted
29	Fan grille	Protects the fan from accidental contact
30	Liquid separator	Accumulates liquid leaving the evaporator so as to prevent it from entering the compressor intake (gas circuit)

TAB. 17 (Designation of the main components - Example model SP-8T)

5.16.2 NAME OF MAIN COMPONENTS (EXAMPLE MODEL XS HIGH VERSION)

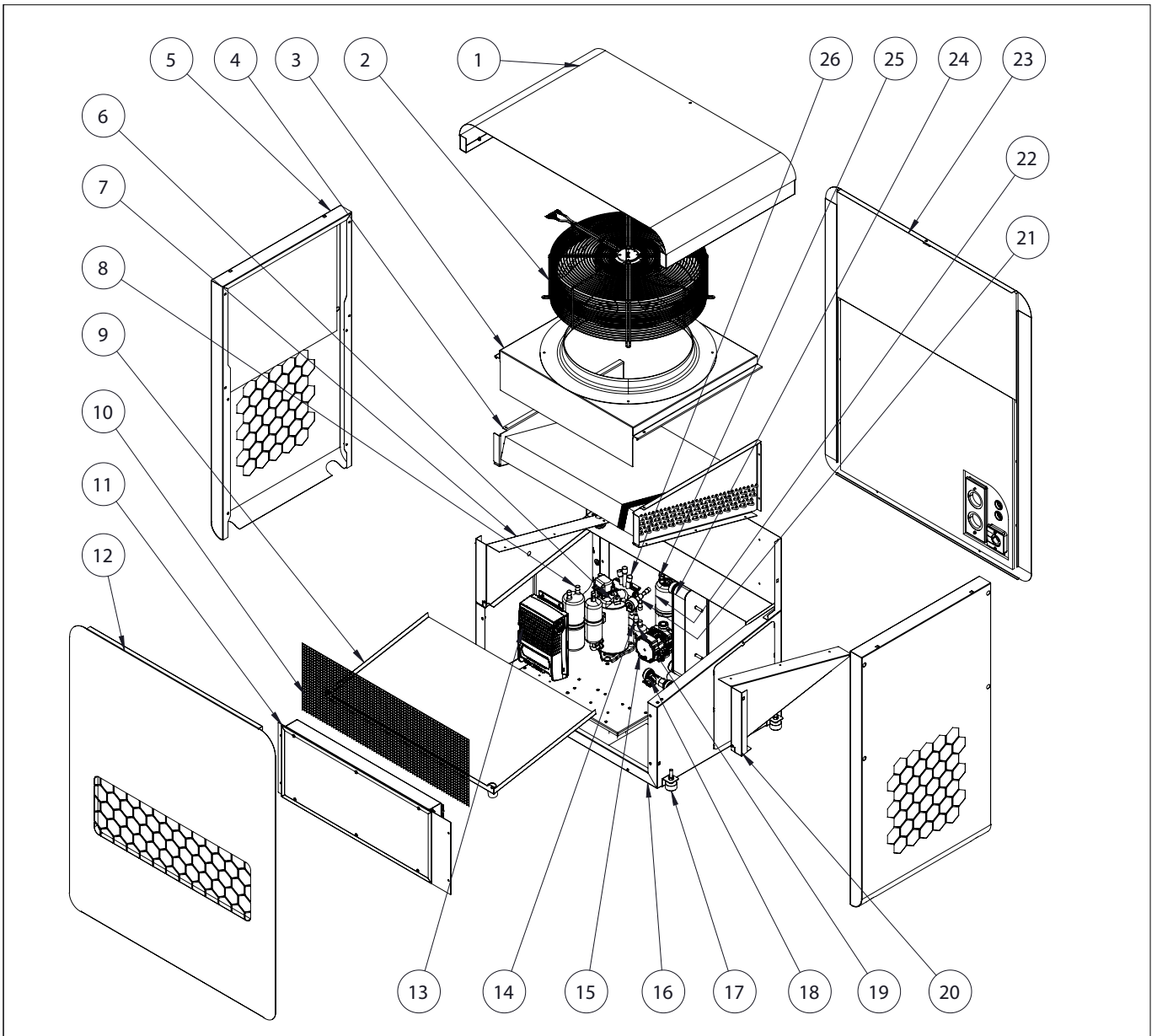

FIG. 26 (Designation of the main components - Example model XS High version)

Ref.	Designation	Main functions
1	Top cover	Protects internal components
2	Fan with protective grille	Conveys outside air to allow air/gas refrigerant exchange on the evaporator Protects the fan from accidental contact
3	Fan support	Allows the fan to be fixed
4	Evaporator	Allows heat exchange between outside air and refrigerant gas (gas circuit)
5	Side panel	Protects internal components
6	Compressor	Compresses the gas to allow it to flow over the gas circuit

continued

Ref.	Designation	Main functions
7	Battery support panel	Supports the evaporator and creates the suction chamber
8	Liquid separator	Accumulates the liquid leaving the evaporator so that it does not enter the compressor suction (gas circuit)
9	Condensate tray	Drains condensate from the evaporator
10	Protection grid	Protects the suction compartment from foreign objects that may clog the evaporator
11	Electrical panel	Contains the electrical components for machine control
12	Front panel	Protects the internal components
13	Inverter	Allows modulation of machine speed
14	Pressure switch	Calibration on refrigerant R290: 29.3 bar
15	Circulation pump (if internal)	Pumps the water (hydraulic circuit)
16	Base plate	Supports the components
17	Adjustable foot	Supports the machine and is used for leveling the machine
18	Flow meter	Measures the flow rate of water (hydraulic circuit)
19	Filter drier	Absorbs moisture and filters acids and solid contaminants from refrigerant gas
20	Battery support panel	Supports the evaporator
21	Electronic expansion valve	Performs lamination (pressure reduction) of the refrigerant gas
22	Liquid receiver	Compensates for charge difference between chiller and heat pump operation
23	Rear closure	Protects internal components
24	Plate heat exchanger	Enables refrigerant gas/water heat exchange (hydraulic circuit)
25	Vent valve	Vents any air or refrigerant gas present in the water (hydraulic circuit)
26	4-way valves	Allows reversal of refrigerant gas flow to switch from summer operation (cooling) to winter operation (heating)

TAB. 18 (Designation of main components-Example model XS High version)

5.17 HCC REMOTE CONTROL



FIG. 28 (HCC Remote control)



⚠ WARNING

IT IS MANDATORY TO REFER TO THE ATTACHED TECHNICAL DOCUMENTATION FOR USE AND OPERATION OF THE HCC REMOTE CONTROL.

5.18 OPTIONAL COMPONENTS

Provided on request

- Anti-vibration supports for floor mounting
- Anti-vibration elements for piping
- Heating element for condensate drain
- Fastening brackets (if legs are not present)

6 GUARDS AND PROTECTIVE DEVICES

6.1 DESIGNATION AND FUNCTIONS

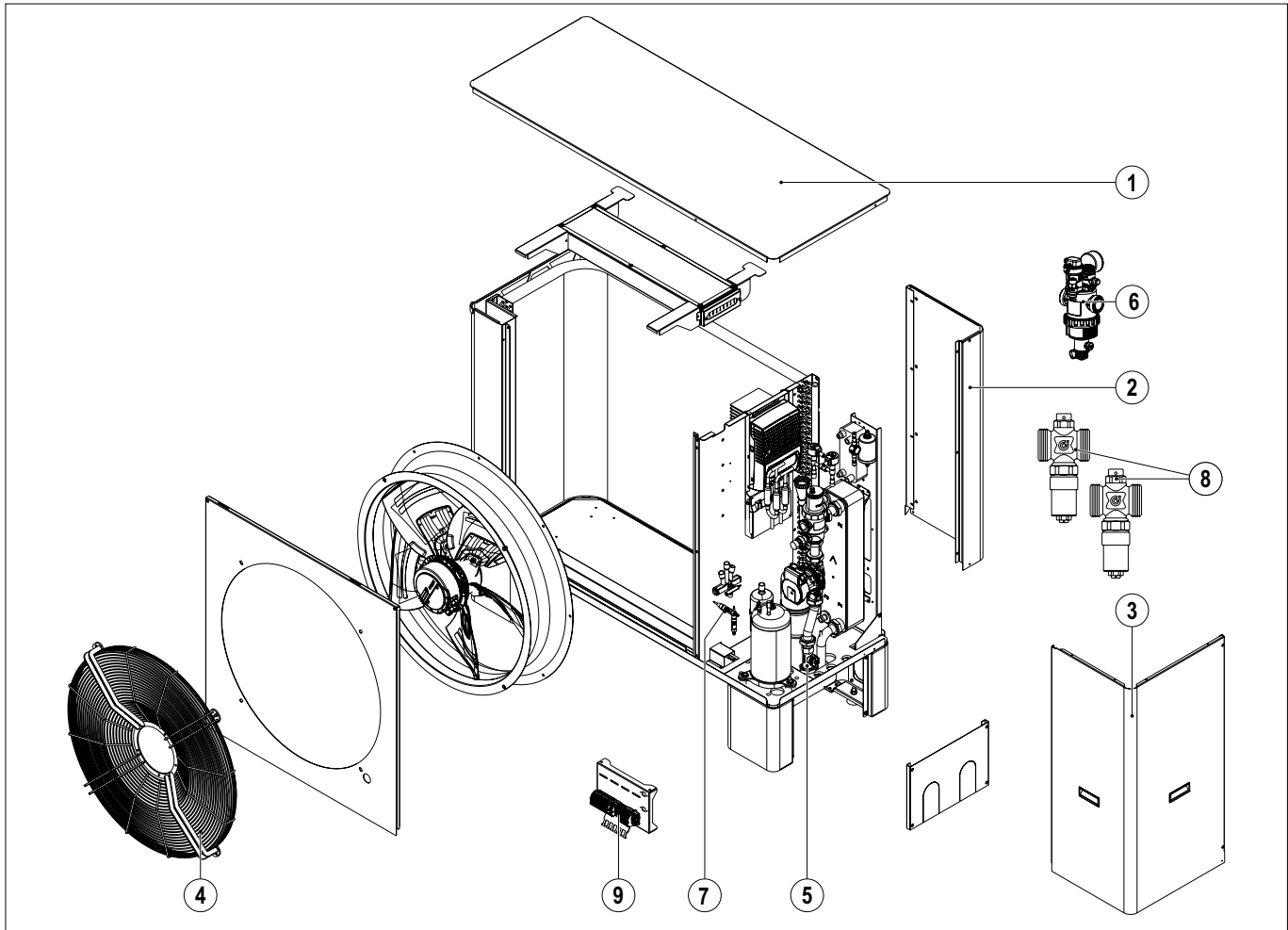

FIG. 29 (Guards and protective devices)

Ref.	Designation	Characteristics
1	Top panel	Shaped sheet metal fastened to the frame with screws
2	Rear panel	Shaped sheet metal fastened to the frame with screws
3	Side panel	Protects internal components
4	Fan grille	Steel wire mesh Ø 3 mm, pitch 10 mm
5	Flowmeter	Manufacturer HUBA control AG, detects the MINIMUM flow. (s. TAB. 14)
6	Magnetic dirt separator (optional)	Protects the circulator from magnetite and the hydraulic system from impurities
7	Pressure switch	Calibration with refrigerant R290: 29.3 bar, with refrigerant R32: 42.8 bar
8	Antifreeze valve (No. 2)	Optional, outside the machine. Caleffi. opens at 3°C and closes at 4°C
9	Fuses	5x20 F std 4a 250 V

TAB. 19 (Guards and protective devices)

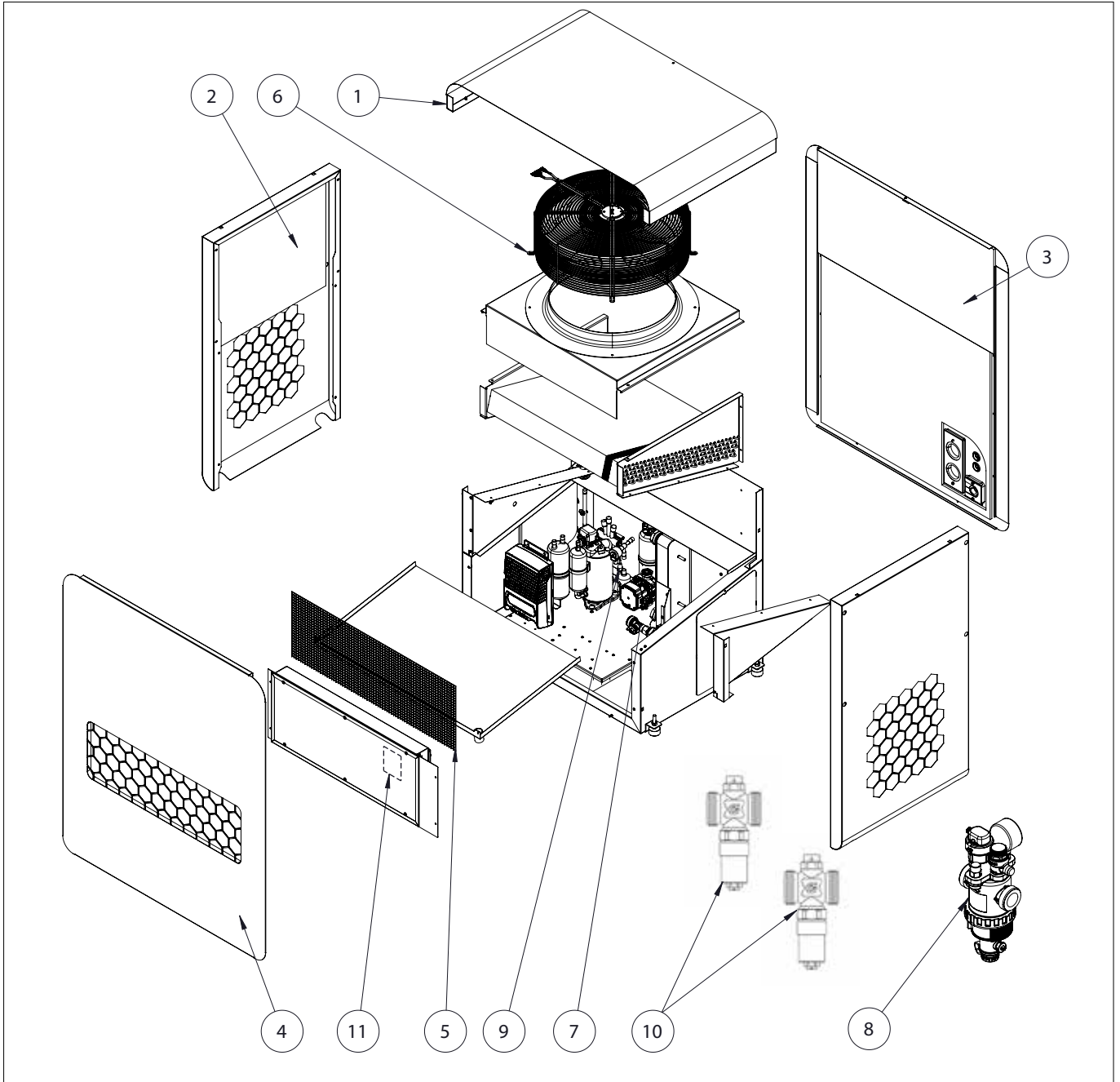

FIG. 30 (Ripari e dispositivi di protezione XS versione Alta e Bassa)

Ref	Designation	Characteristics
1	Top cover	Molded sheet attached to the frame with screws, protects internal components
2	Side panel	Molded sheet attached to the frame with screws, protects internal components
3	Rear cover	Molded sheet attached to the frame with screws, protects internal components
4	Front panel	Molded sheet attached to the frame with screws, protects internal components
5	Protective grille	Square mesh perforated net, thickness 1mm pitch 10mm

continua

Ref	Designation	Characteristics
6	Fan grille	Steel wire mesh Ø 3 mm, pitch 10 mm
7	Flow meter	Manufacturer HUBA Control AG detects MIN flow. (see TAB. 14)
8	Magnetic defogger (optional)	Protects the circulator from magnetite and the hydraulic system from impurities
9	Pressure switch	Calibration with R290 refrigerant: 29.3 bar, with R32 refrigerant: 39.5 bar
10	Antifreeze valve (nr.2)	Optional, external to the machine. Caleffi. opens at 3°C and closes at 4°C
11	Fuses (inside the electrical panel)	5x20 F std 4a 250 V

TAB. 20 (Ripari e dispositivi di protezione)



⚠ DANGER

IT IS PROHIBITED TO NEUTRALISE, TAMPER WITH, MANIPULATE OR BYPASS THE GUARDS AND PROTECTIVE DEVICES INSTALLED ON THE MACHINE

IT IS PROHIBITED TO REPLACE THE MACHINE GUARDS AND PROTECTIVE DEVICES USING NON-ORIGINAL PARTS.



⚠ WARNING

IT IS MANDATORY TO KEEP A CONSTANT CHECK ON THE PROPER OPERATION OF ALL GUARDS AND PROTECTIVE DEVICES.

IT IS MANDATORY TO REPLACE ANY INEFFECTIVE OR DAMAGED GUARDS AND PROTECTIVE DEVICES.



INFORMATION

THE PROCEDURES FOR ORDERING ORIGINAL SPARE PARTS FOR GUARDS AND PROTECTIVE DEVICES ARE SHOWN IN CHAP. 18.

7 SAFETY AND INFORMATION SIGNS

The safety and information signs are composed of a series of decals affixed to the machine as shown in FIG. 24.



⚠ WARNING

YOU MUST KEEP THE SAFETY SIGNS CLEAN TO ENSURE THEY ARE CLEARLY VISIBLE.

IT IS MANDATORY TO REPLACE ANY DAMAGED OR DEFACED SAFETY SIGNS, ORDERING NEW ONES FROM THE MANUFACTURER OR SERVICE CENTRE.



⚠ WARNING

IT IS PROHIBITED TO REMOVE AND/OR DAMAGE THE SAFETY SIGNS AFFIXED TO THE MACHINE.

7.1 SAFETY SIGN DECALS

SIGN	MEANING	SIGN	MEANING
	WARNING Flammable material		OBLIGATION Read the instruction manual.

TAB. 21 (Sign decals - Meaning of signs)

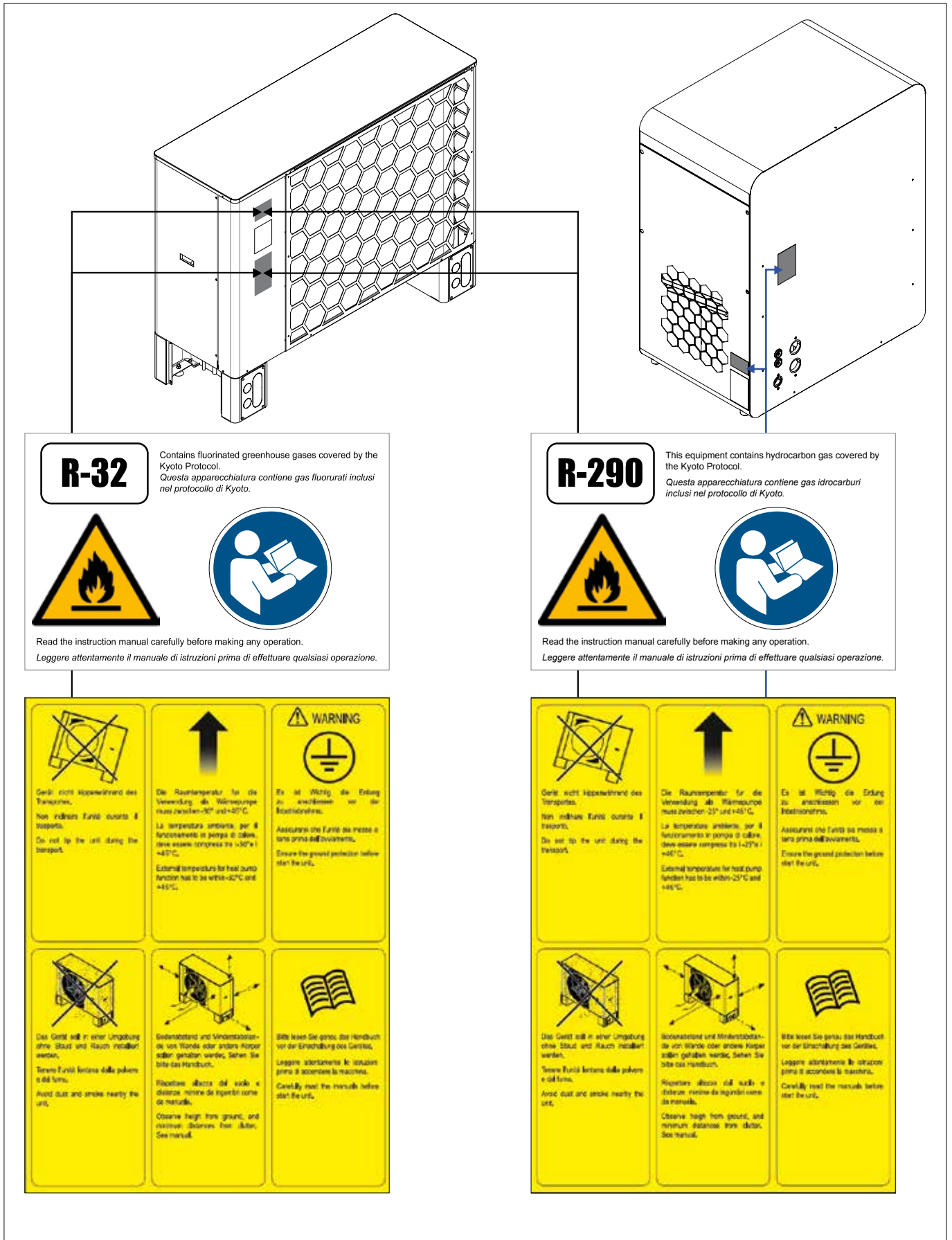

FIG. 31 (Safety sign decals on the machine)

8 RESIDUAL RISKS

The authorised operator is informed that although the Manufacturer has adopted all possible technical solutions to make the machine safe, certain residual risks remain, as described hereunder.

DANGER



TO MINIMISE EXPOSURE TO RESIDUAL RISKS IT IS PROHIBITED TO USE THE MACHINE INCORRECTLY (**S. PAR. 5.3**) OR IN A MANNER THAT DIFFERS FROM THE USE INTENDED BY THE MANUFACTURER (**S. PAR. 5.2**).

IT IS MANDATORY TO COMPLY WITH THE SAFETY SIGNS (**S. CHAP. 7**) AND WEAR THE PERSONAL PROTECTIVE EQUIPMENT (**S. CHAP. 9**) PRESCRIBED BY THIS MANUAL.

RISCHIO RESIDUO N. 1



THERE IS A **RISK OF OVERTURNING** IF THE AUTHORIZED OPERATORS OPERATE ON THE MACHINE BEFORE SECURING IT AND FAIL TO COMPLY WITH THE FOLLOWING PRESCRIPTIONS:

- IT IS MANDATORY TO WEAR THE PRESCRIBED PPE (**S. CHAP. 9**)
- IT IS MANDATORY TO COMPLY WITH THE PROCEDURES FOR CORRECT USE AND MAINTENANCE.

RISCHIO RESIDUO N. 2



THERE IS A **RISK OF ELECTRIC SHOCK** DUE TO ACCIDENTAL CONTACT WITH LIVE ELECTRICAL PARTS IF THE AUTHORIZED OPERATORS FAIL TO COMPLY WITH THE FOLLOWING PRESCRIPTIONS:

- IT IS MANDATORY TO WEAR THE PRESCRIBED PPE (**S. CHAP. 9**)
- IT IS MANDATORY TO COMPLY WITH THE PROCEDURES FOR CORRECT USE AND MAINTENANCE.

RISCHIO RESIDUO N. 3



THERE IS A **RISK OF BURNS OR FREEZING** DUE TO ACCIDENTAL CONTACT WITH HOT OR COLD PARTS IF THE AUTHORIZED OPERATORS FAIL TO COMPLY WITH THE FOLLOWING PRESCRIPTIONS:

- IT IS MANDATORY TO WEAR THE PRESCRIBED PPE (**S. CHAP. 9**)
- IT IS MANDATORY TO WAIT FOR THE TIME NECESSARY TO REACH ROOM TEMPERATURE
- IT IS MANDATORY TO COMPLY WITH THE PROCEDURES FOR CORRECT USE AND MAINTENANCE.

RISCHIO RESIDUO N. 4



THERE IS A **RISK OF CUTTING** DUE TO ACCIDENTAL CONTACT WITH THE SHARP EDGES OF THE MACHINE IF THE AUTHORIZED OPERATORS FAIL TO COMPLY WITH THE FOLLOWING PRESCRIPTIONS:

- IT IS MANDATORY TO WEAR THE PRESCRIBED PPE (**S. CHAP. 9**)
- IT IS MANDATORY TO COMPLY WITH THE PROCEDURES FOR CORRECT USE AND MAINTENANCE.

RISCHIO RESIDUO N. 5



THERE IS A **RISK OF FIRE AND EXPLOSION** OF THE REFRIGERANT CONTAINED IN THE MACHINE IF THERE IS A LEAKAGE OF REFRIGERANT THAT COMES INTO CONTACT WITH THE AIR, RESULTING IN THE FORMATION OF A COMBUSTIBLE ATMOSPHERE, OR IF THE AUTHORIZED OPERATORS FAIL TO COMPLY WITH THE FOLLOWING PRESCRIPTIONS:

- IT IS MANDATORY TO USE SUITABLE EQUIPMENT
- IT IS MANDATORY TO COMPLY WITH THE PROCEDURES FOR CORRECT USE AND MAINTENANCE.
- PROHIBITION OF THE USE OF OPEN FLAMES AND PROHIBITION OF HEAT-GENERATING ACTIVITIES

9 PERSONAL PROTECTIVE EQUIPMENT (PPE)



The use of Personal Protective Equipment (PPE) is mandatory in compliance with legislation concerning health and safety in the workplace in force in the country in which the machine is put into service.

The employer and authorised operators must be informed of and apply the obligations and duties prescribed by the foregoing legislation.



⚠ WARNING



IT IS PROHIBITED TO WEAR CLOTHING AND ACCESSORIES THAT MAY BECOME ENTRAPPED IN THE MACHINE (LOOSE FITTING GARMENTS, TIES, BELTS, NECKLACES, BRACELETS, WATCHES, EARRINGS, RINGS, ETC.) AND IT IS MANDATORY TO TIE BACK LONG HAIR.

Sign	Mandatory PPE for installation operators
	HAND PROTECTION: Protective gloves against sharp edges and protective gloves against heat
	FOOT PROTECTION: Non-slip shoes with reinforced toecap
	BODY PROTECTION: Protective clothing

TAB. 22 (Personal protective equipment - PPE)

10 WORK STATIONS

Depending on the type of action, authorised operators must occupy exclusively the work stations shown in **FIG. 25** and described in the following table.

Authorised operators	Work station	Action description
	On the four sides of the machine	To assemble the machine(s. par. 16.2)
	A	To carry out routine maintenance (s. par. 16.2)
	B	To carry out routine maintenance (s. par. 16.2)

TAB. 23 (Work stations)

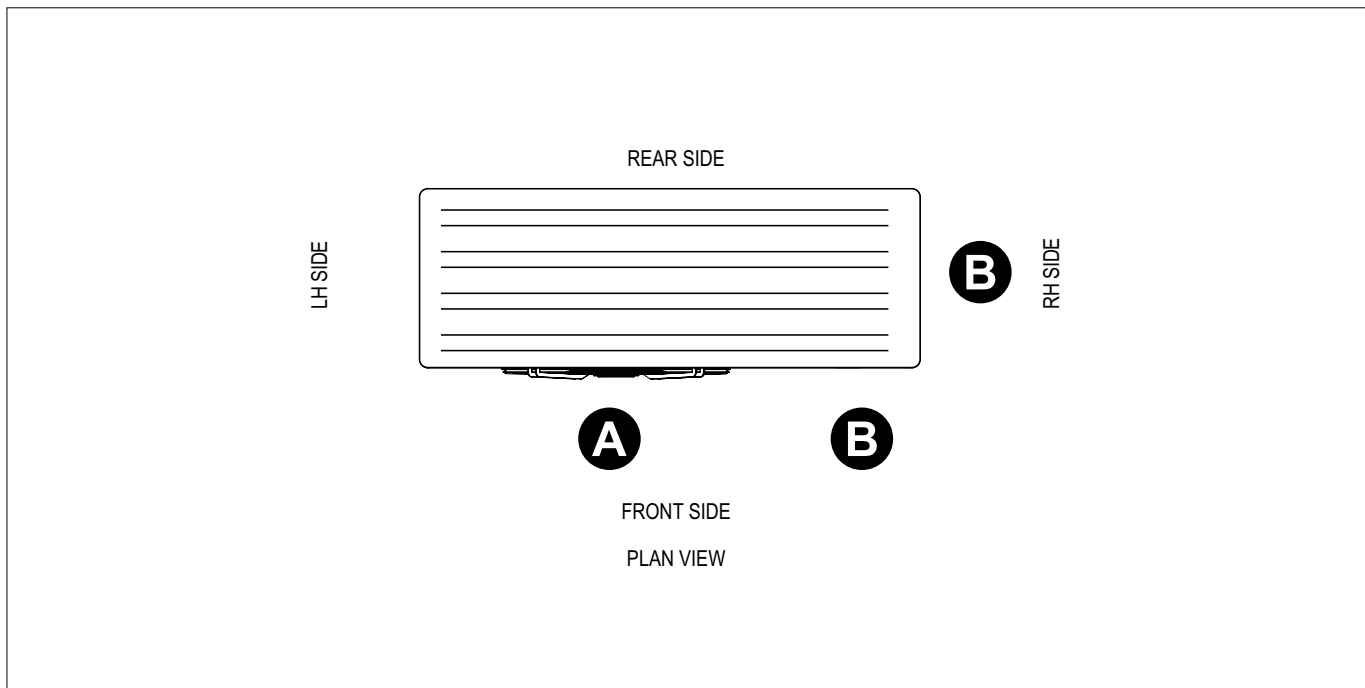

FIG. 32 (Work stations)

11 TRANSPORT AND HANDLING



The machine is generally transported to the customer's site by the Manufacturer or by a specialised shipping company that uses its own personnel and suitable means for the task and proceeds in compliance with statutory legislation to guarantee loading, transport and unloading operations in relation to the transportation type (land, sea or air).

11.1 PACK AND PACK CONTENTS



The machine is delivered wrapped in nylon and cardboard. The weight of each pack is specified in the lifting instructions on the pack in question (**s. par. 19.1**).

Machine mass	
Series	kg
XS	200
HRP	230
SP-T	180
S-T	180
MP	220
LP	280
LP PLUS	320
LR	280
LR PLUS	320

TAB. 24 (Contents of the pack)

11.2 UNPACKING THE MACHINE COMPONENTS



Place the pack containing the components on the ground on a flat, level and stable surface.

Unpack the machine as follows:

- 1) Remove plastic material and protective cardboard
- 2) Check the contents of the pack (**s. par. 11.1**).
- 3) If any machine components show signs of damage or anomalies, inform the Manufacturer and do not use the machine.



⚠ CAUTION

THE PACK MUST BE DISPOSED OF IN ACCORDANCE WITH THE TYPES OF MATERIAL OF WHICH IT IS COMPOSED AND IN FULL COMPLIANCE WITH STATUTORY LEGISLATION IN FORCE IN THE COUNTRY IN WHICH THE MACHINE IS PUT INTO SERVICE.

11.3 HANDLING WITH CRANE OR OVERHEAD CRANE



⚠ DANGER

IT IS MANDATORY TO MAKE SURE THERE ARE NO PERSONS, ANIMALS AND/OR OBJECTS WITHIN THE OPERATING RANGE OF THE JIB CRANE OR OVERHEAD TRAVELLING CRANE.

MAKE SURE THE HARNESS DOES NOT STRIKE OR DAMAGE THE MACHINE COMPONENTS.

⚠ WARNING

THE MACHINE MUST BE HANDLED WITH AN OVERHEAD TRAVELLING CRANE OR A JIB CRANE SUITABLE FOR THE APPLICATION AND WITH ADEQUATE LOAD CAPACITY.

IT IS MANDATORY TO USE LIFTING ACCESSORIES (ROPES, SLINGS, HOOKS, SHACKLES) SUITABLE FOR THE INTENDED USE AND LOAD (**V. PAR. 5.7**) AND IN COMPLIANCE WITH STATUTORY LEGISLATION.

⚠ WARNING

DO NOT MAKE ABRUPT MOVEMENTS DURING HANDLING OPERATIONS (LIFTING/LOWERING AND TRANSLATION) TO AVOID COMPROMISING THE STABILITY OF THE LOAD AND THE SAFETY OF THE AUTHORIZED OPERATORS.

Proceed as follows to handle the machine:

- 1) Make sure that the machine is free from any obstructions
- 2) Harness or hook the lifting accessories as shown in **FIG. 26**
- 3) Raise the machine just a few centimeters from the ground to check weight distribution, do not exceed an incline of **45°**
- 4) Move the machine carefully.
- 5) Lower the machine fully until it is resting on a flat, level and stable surface.
- 6) Remove the lifting accessories.

⚠ CAUTION

THE LOAD CAPACITY OF THE ROPES, STRAPS AND/OR SLINGS DECREASES AS THE "**β**" (**S. FIG. 26**) ANGLE INCREASES.

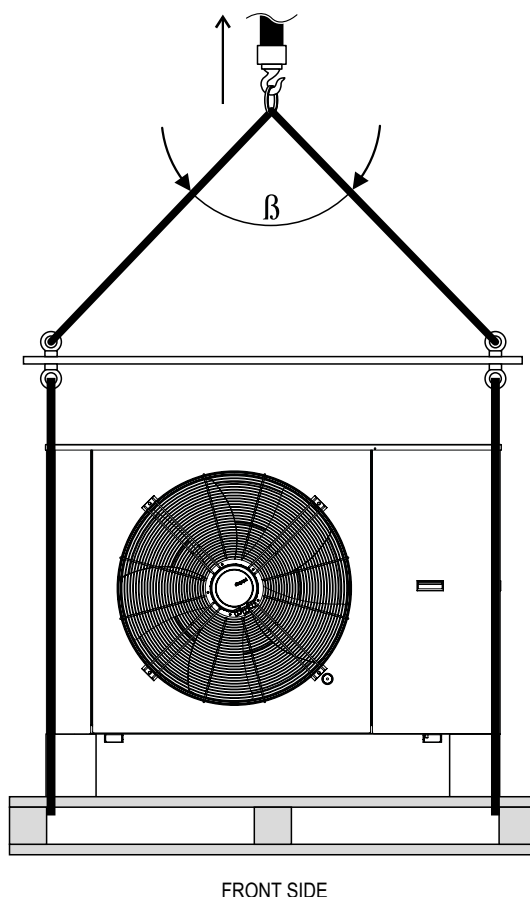

FIG. 33 (Handling with crane or overhead crane)

11.4 HANDLING WITH FORKLIFT TRUCK



⚠ WARNING



THE INSTRUCTIONS FOR HANDLING THE MACHINE ARE SHOWN ON A SHEET AFFIXED TO THE OUTSIDE OF THE PACK (S. PAR. 19.1).

HANDLE THE MACHINE USING A SUITABLE FORKLIFT TRUCK WITH AN ADEQUATE LIFTING CAPACITY.



⚠ DANGER

IT IS MANDATORY TO ENSURE THERE ARE NO PERSONS, ANIMALS, AND/OR OBJECTS IN THE OPERATING RANGE OF THE FORKLIFT TRUCK.



⚠ WARNING

DO NOT MAKE ABRUPT MOVEMENTS DURING HANDLING OPERATIONS (LIFT/LOWER AND TRANSLATION) TO AVOID THE ASSOCIATED LOSS OF STABILITY.

Proceed as follows to handle the machine:

- 1) Make sure the machine is free from obstacles
- 2) Insert the forks of the forklift truck (s. FIG. 27) under the pallet or baseboard at the rear of the machine or on the side of the fittings
- 3) Protect the side wall of the machine that comes into contact with the truck to avoid scratches and damage
- 4) Check that the forks of the forklift truck are protruding from the opposite side to the insertion side.
- 5) Raise the package just a few centimeters from the ground to make sure the weight is evenly distributed
- 6) Move the pack carefully
- 7) Lower the pack fully until it is resting on a flat, level and stable surface
- 8) Withdraw the forklift truck forks.

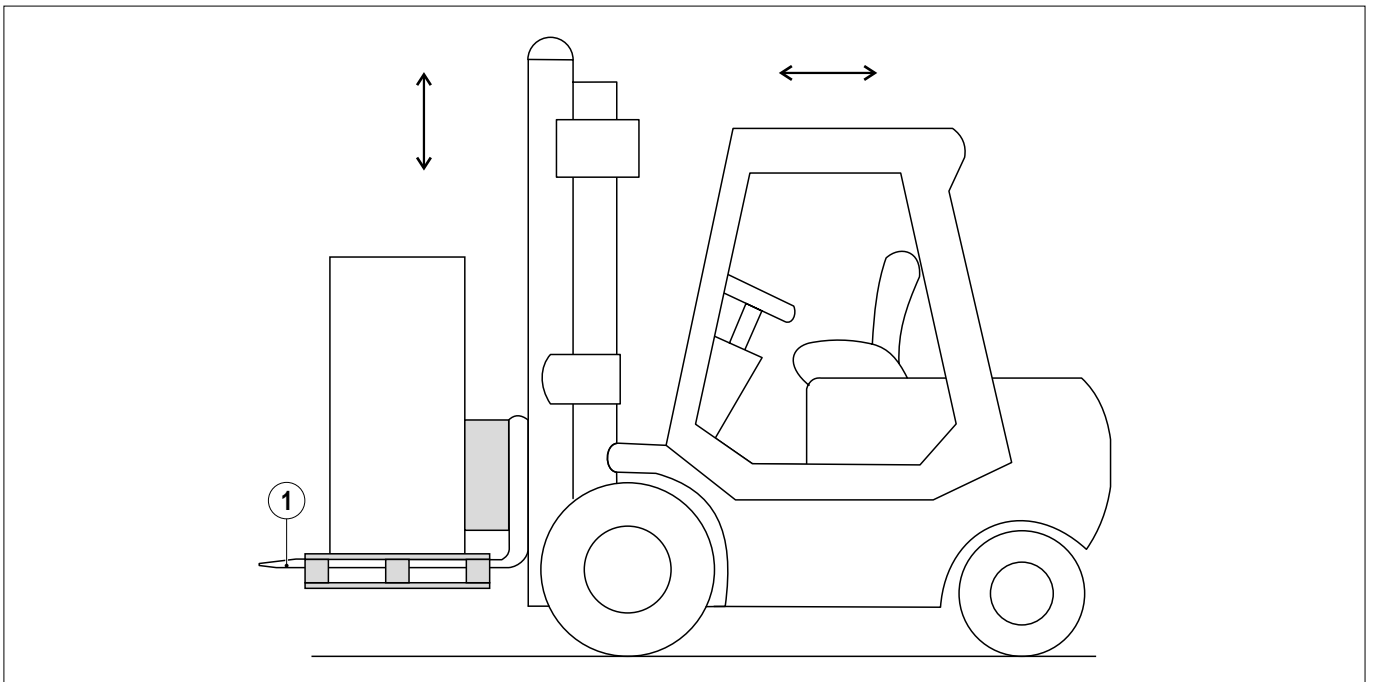

FIG. 34 (Handling with a forklift truck)

12 STORAGE



If the machine is to remain unused for a prolonged period, proceed as follows:

- 1) Check that the machine is in “**safety status**” (s. par. 5.1)
- 2) Grease the mechanical parts
- 3) Clean the machine
- 4) Protect the machine with tarpaulins or other protective measures to prevent the accumulation of dust



⚠ CAUTION

DO NOT STORE THE MACHINE IN A PLACE WHERE IT IS EXPOSED TO THE WEATHER, DIRECT SUNLIGHT AND DUST.

13 INSTALLATION



The machine must be located outside buildings, in a sufficiently ventilated place, suitable for the legal provisions in force in the country where the machine is to be put into service with regard to safety, and in compliance with the environmental conditions and operating limits given in (s. par. 5.7).



The machine must be mounted on a flat, level and stable surface.

The floor must be able to withstand the loads transmitted by the machine.

Respect the minimum distances shown in **TAB. 23** to ensure sufficient air flow and to facilitate maintenance operations.



⚠ WARNING

THE PROTECTED AREA (IF ANY) MUST NOT OCCUPY PARKING SPACES, ADJACENT LAND OR PUBLIC ROADS. IN THE CASE OF INSTALLATION IN THE VEHICLE MANOEUVRING AREA, ROBUST COLLISION PROTECTION IS REQUIRED OUTSIDE THE PROTECTED AREA.



⚠ WARNING

IT IS FORBIDDEN TO INSTALL THE MACHINE ON A SLOPING ROOF OR IN A PIT.



INFORMATION

CHECK THAT THERE IS SUFFICIENT SPACE FOR THE INSTALLATION OF HYDRAULIC PIPES.

IF THE MACHINE IS INSTALLED IN AREAS SUBJECT TO HEAVY SNOWFALL, MAKE SURE THAT SNOW DOES NOT ACCUMULATE AROUND THE MACHINE AND THAT THE MINIMUM DISTANCES INDICATED BELOW ARE RESPECTED. IF THESE CONDITIONS CANNOT BE MET, INSTALL AN ADDITIONAL THERMAL GENERATOR IN THE HEATING CIRCUIT.

IT IS NECESSARY THAT THE MACHINES BE INSTALLED IN A LOCATION SHELTERED FROM THE WIND.

IN THE EVENT OF STRONG WINDS, ESPECIALLY ICY WINDS OR SNOWSTORMS, THE MACHINES MUST BE SWITCHED OFF (SELECT OFF ON THE PANEL). OTHERWISE, THE DEFROST CYCLE MAY BE PREVENTED, RESULTING IN DAMAGE TO THE COMPRESSOR.

13.1 CHOICE OF INSTALLATION SITE

To install the machine, check:

- prevailing winds
- noise emissions of the fan and compressor
- environmental visual impact
- avoid locations where strong winds can affect the air exhaust of the machine

If necessary to avoid production of loud noise, install the machine on one of the following supports:

- concrete floor
- steel T-beam
- concrete block

Series	Distance	mm
XS low version	A	>300
	B	>300-1000*
Series	Distance	mm
XS high version	A	>400
	B	>400-1000*

*Recommended for ease of disassembly

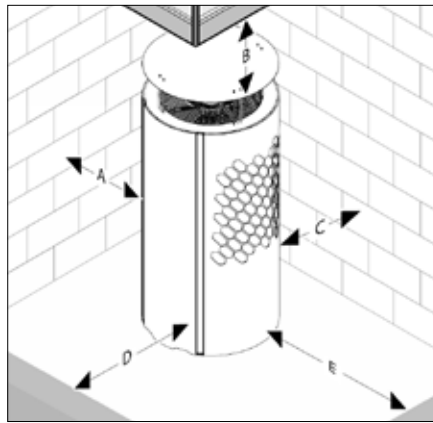
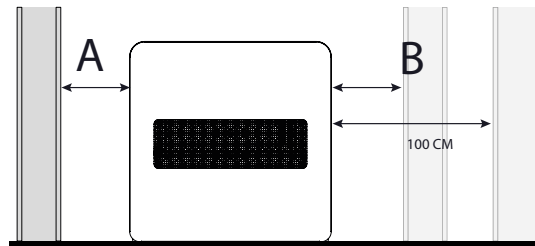

Series	Distance	mm
HRP	A	>800
	B	>300
	C	>800
	D	>800
	E	>2500

Series	Ref.	mm
All	A	>300
All	B	>2500
S	C	>300
M		>400
L		>500
All	D	>3000
All	E	>1000

TAB. 25 (Installation)

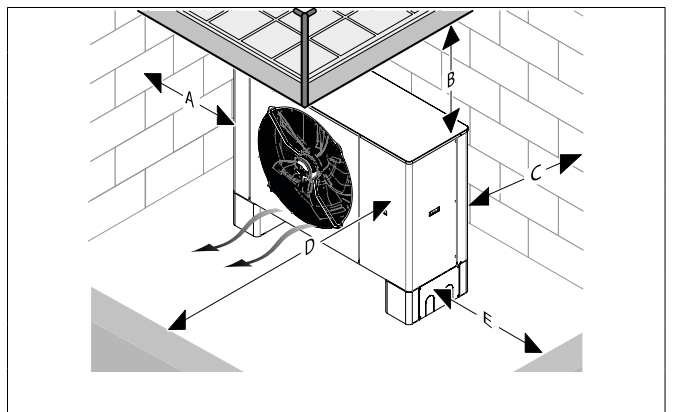

⚠ WARNING

IT IS MANDATORY TO GUARANTEE THE MINIMUM POSITIONING CLEARANCES SHOWN IN FIG. 28 TO ALLOW AUTHORISED OPERATORS TO OCCUPY THE PRESCRIBED WORK STATIONS.



⚠ WARNING

IT IS MANDATORY TO ARRANGE THE LAYING OF ELECTRICAL CABLES FOLLOWING THE DIMENSIONS OF THE MACHINE MODEL (S. PAR. 5.5).

13.2 SAFETY ZONE (FOR R290 REFRIGERANT TYPE ONLY)

INFORMATION

THE R290 REFRIGERANT CONTAINED IN THE MACHINE HAS A HIGHER DENSITY THAN AIR. IN THE EVENT OF LEAKAGE, THE LEAKING COOLANT MAY ACCUMULATE AT GROUND LEVEL.



THE REFRIGERANT MUST NOT ACCUMULATE IN SUCH A WAY AS TO CREATE A DANGEROUS, EXPLOSIVE, SUFFOCATING OR TOXIC ATMOSPHERE. THE REFRIGERANT MUST NOT GET INTO BUILDING THROUGH ITS OPENINGS AND MUST NOT ACCUMULATE IN GROOVES OR INTO WASTE-WATER SYSTEM.

ENSURE THAT IN THE SAFETY ZONE THERE ARE NO IGNITION SOURCES SUCH AS SOCKETS, LIGHT SWITCHES, LAMPS, ELECTRICAL SWITCHES, HEATING MUSHROOMS, GRILLS OR OPEN FLAMES OR OTHER PERMANENT IGNITION SOURCES WITH TEMPERATURES >360 °C.

⚠ WARNING



THE MACHINE MUST BE INSTALLED SO THAT, IN THE EVENT OF LEAKS, THE REFRIGERANT FLUID DOES NOT PENETRATE INSIDE BUILDINGS OR INDOORS.

ENSURE THAT IN THE SAFETY ZONE THERE ARE NO WINDOWS, DOORS, VENTILATION OPENINGS, CAVITIES, CELLAR ACCESSES, MANHOLES, SKYLIGHTS, GUTTERS OR OTHER COMPARTMENTS THAT ARE NOT HERMETICALLY SEALED IN THE PROTECTED AREA.

THE SAFETY ZONE SHALL NOT EXTEND TO NEIGHBOURING PROPERTIES OR AREAS WITH PUBLIC TRAFFIC

NO STRUCTURAL CHANGES MUST BE MADE IN THE SAFETY AREA IN BREACH OF THESE RULES.

13.2.1 SAFETY ZONE FOR GROUND (OR FLAT ROOF) INSTALLATION

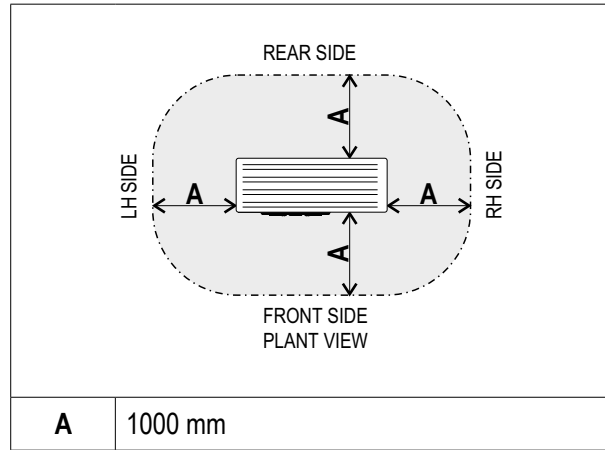

FIG. 35 (Safety zone for ground - or flat roof - installation)

13.2.2 SAFETY ZONE FOR GROUND INSTALLATION IN FRONT OF A BUILDING WALL

With reference to **TAB. 23**, **C** is the minimum distance from the wall.

If **C** exceeds **1000 mm**, refer to **par. 13.1**.

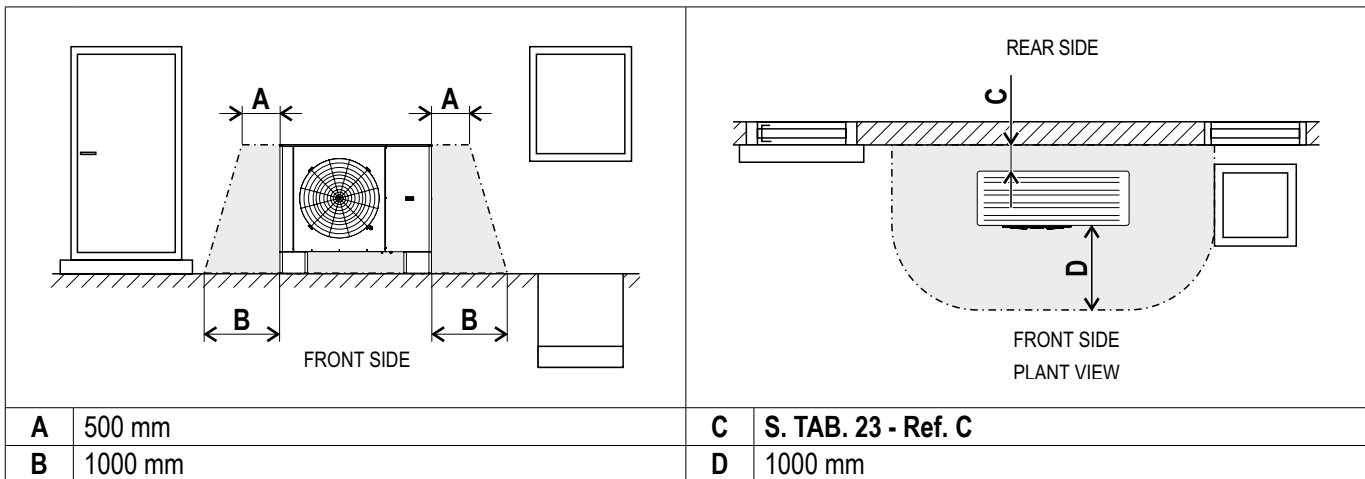

FIG. 36 (Safety zone for ground installation in front of a building wall)

13.2.3 SAFETY ZONE FOR GROUND INSTALLATION IN A BUILDING CORNER

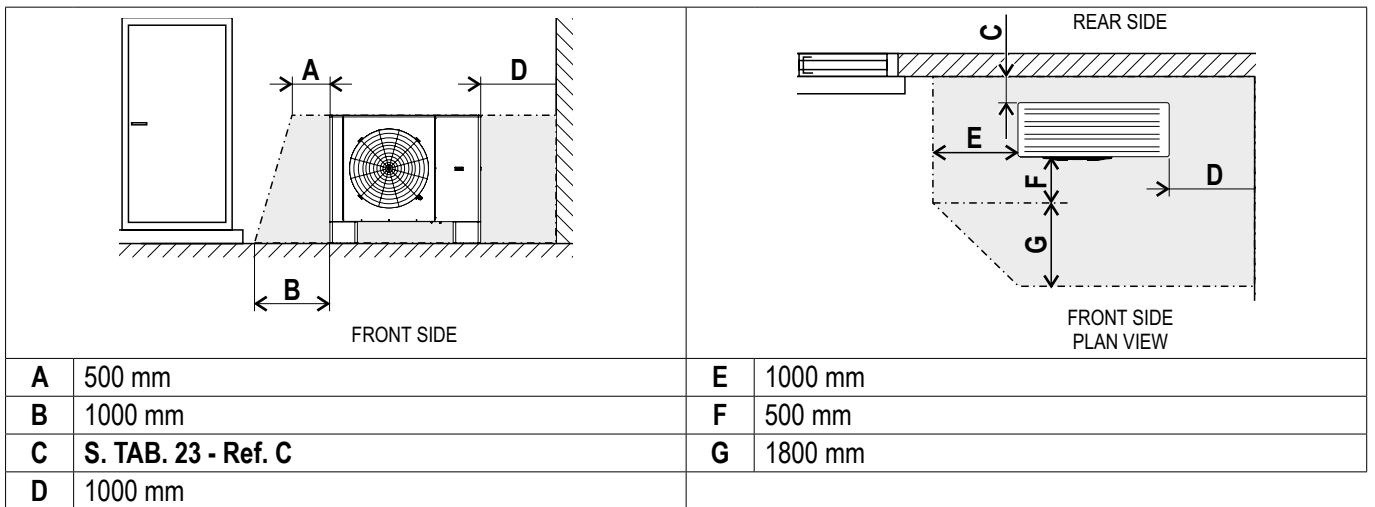

FIG. 37 (Safety zone for ground installation in a building corner)

13.2.4 SAFETY ZONE FOR WALL INSTALLATION IN FRONT OF A BUILDING WALL

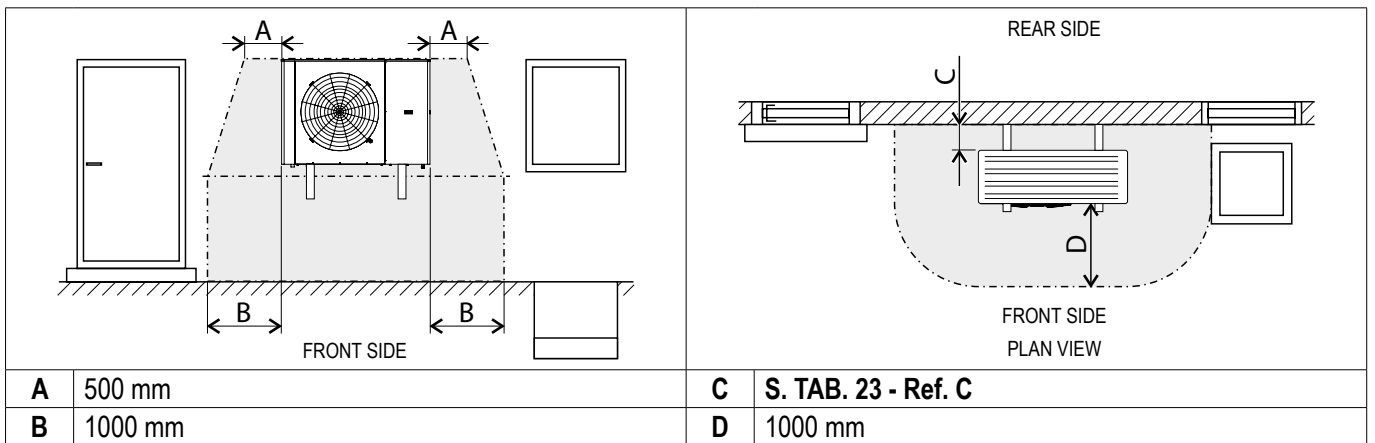

FIG. 38 (Safety zone for wall installation in front of a building wall)

13.2.5 SAFETY ZONE FOR WALL INSTALLATION IN A BUILDING CORNER

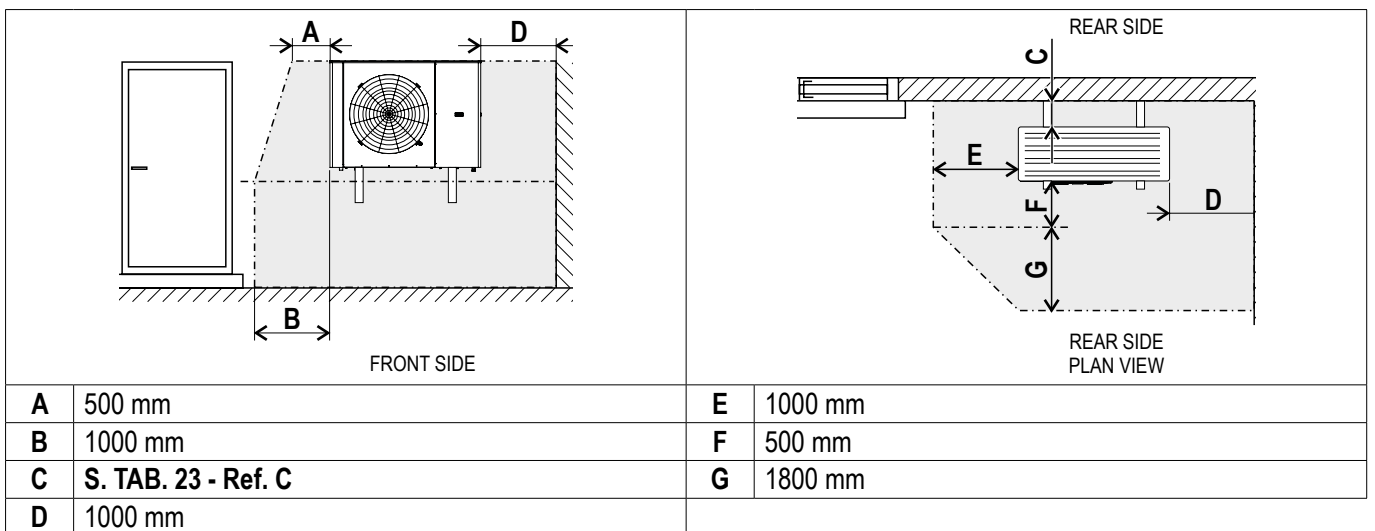

FIG. 39 (Safety zone for wall installation in a building corner)

13.3 ASSEMBLY EQUIPMENT

To assemble the machine, use:

- Phillips and slotted screwdriver set
- Wire cutters
- Electrician's scissors
- Wrench and pipe turner set
- Ladder or scaffolding
- Plumbing material for thread sealing
- Electrical equipment for connections
- Tester and ampere tester
- Ground or wall mounting devices
- Compulsory PPE (s. chap. 9)

13.4 USEFUL COMPONENTS FOR INSTALLATION

The installer must choose and install the necessary system components. Below are some useful components for installing the machine:

- **Circuit inlet and outlet shut-off valves** allow maintenance operations without having to empty the system
- **Pressure relief valve** on the hydraulic circuit
- **Thermometers and pressure gauges** at the inlet and outlet of the main components ensure better monitoring and facilitate maintenance
- **Venting valves** at the highest points of the system guarantee the venting of air from the circuit
- **Drainage taps** in the lower part of the system to facilitate emptying
- **Expansion tank** to maintain the correct water pressure by compensating for thermal expansions, must be sized considering the total volumes of water in the system

⚠ WARNING

IF GLYCOL IS USED, COLLECT IT ON THE PRESSURE RELIEF VALVE TO AVOID POLLUTING THE ENVIRONMENT.

RINSE THE HEATING SYSTEM THOROUGHLY BEFORE CONNECTING TO REMOVE ANY RESIDUES. WELDING RESIDUES, FLAKES, HEMP, PUTTY, RUST AND THE LIKE FROM THE PIPES CAN BUILD UP IN THE MACHINE CIRCUIT CAUSING ANOMALIES.

IT IS MANDATORY TO INSTALL A MAGNETIC DIRT SEPARATOR TO AVOID DAMAGING THE MACHINE. OTHERWISE THE WARRANTY WILL BE VOIDED.

IT IS MANDATORY TO INSTALL A PRESSURE RELIEF VALVE ON THE HYDRAULIC SYSTEM CALIBRATED TO A PRESSURE >2.5 bar.



13.5 ASSEMBLING THE MACHINE

⚠ WARNING

THE MACHINE IS ASSEMBLED BY THE INSTALLER (S. PAR. 2.4).

THE MACHINE MUST BE FIXED AND LEVELED TO THE FLOOR OR WALL WITH SUITABLE DEVICES ON STEEL BEAMS, CONCRETE BLOCKS, OR FOUNDATIONS.

WATER MUST NOT ACCUMULATE UNDER THE MACHINE.

THE FLOOR IN FRONT OF THE MACHINE MUST ABSORB WATER TO AVOID THE FORMATION OF ICE, PREVENTING CONDENSATION FROM FREEZING ON ACCESS PATHS, WHICH COULD CAUSE ACCIDENTAL FALLS.

CHECK THAT THE DUCTWORK, IMPLEMENTED BY THE MANUFACTURER BY MEANS OF TWO RUBBER PIPES, IS ASSEMBLED ON THE MACHINE ON THE PRESSURE RELIEF VALVE OUTLET.

MAKE SURE THAT NO AIR ENTERS THE REFRIGERANT CIRCUIT, THE TOOLS OR APPLIANCES THAT CARRY REFRIGERANT, OR THE REFRIGERANT CYLINDER. KEEP IN MIND THAT REFRIGERANTS R290 AND R32 MUST NEVER BE DISCHARGED INTO THE SEWERAGE SYSTEM.

MAKE SURE THAT THE PLACE OF INSTALLATION IS NOT PARTICULARLY PRONE TO POLLUTION OR THE PRESENCE OF PARTICULATES (DUST, LEAVES, ETC.).



The machine must be installed in the place of use prepared by creating the foundations and excavations (s. FIG. 34) for laying pipes and cables (by the customer).

The machine must be installed in a sufficiently illuminated premises in compliance with the safety provisions in force in the country of use and in compliance with the ambient conditions and operating limits specified in (s. par. 5.7). The machine must be mounted on a flat, level and stable surface.

The installation of the machine must ensure minimum positioning measurements to enable authorized operators to occupy positions to carry out maintenance (s. FIG. 28).

13.6 LEVELLING THE MACHINE

Level the machine as follows:

- 1) Place a level (FIG. 36 -Ref. 1) in the longitudinal and transverse direction of the machine
- 2) Use the nuts (FIG. 36 -Rif. 2) to level the machine
- 3) Tighten the locknuts when the operation is complete

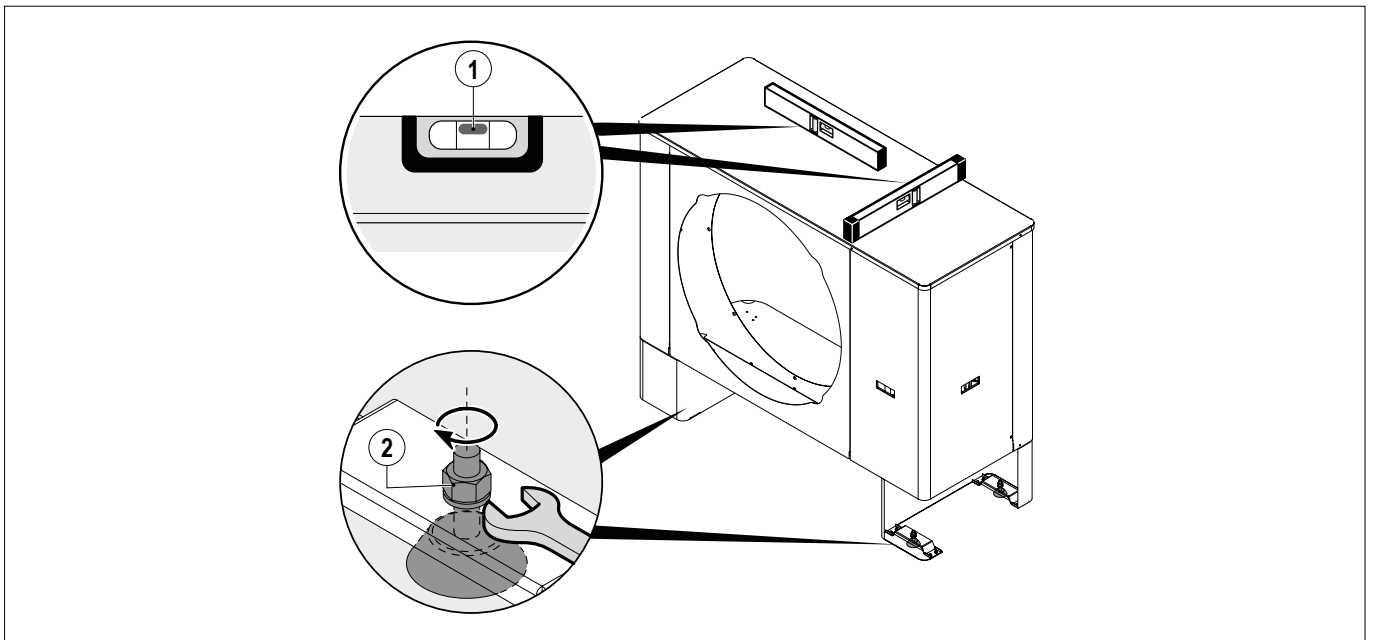

FIG. 40 (Levelling the machine)

Level the machine as follows:

- 1) Place a level (**FIG. 36 -Ref. 1**) in the longitudinal and transverse direction of the machine
- 2) Use the nuts (**FIG. 36 -Rif. 2**) to level the machine
- 3) Tighten the locknuts when the operation is complete

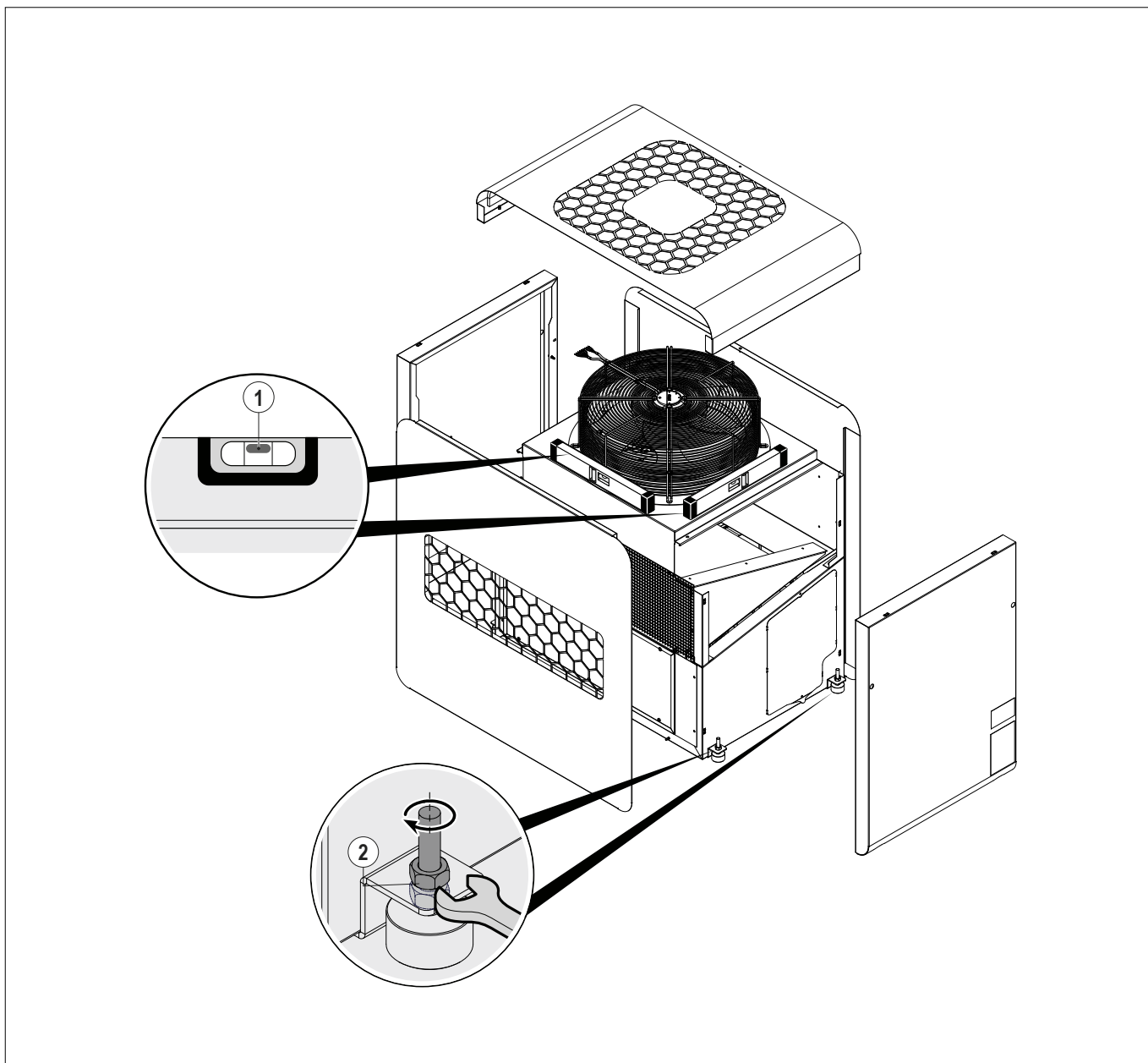

FIG. 41 (Levelling the machine)

13.7 INSTALLING THE PROBES



⚠ WARNING

THE PROBES USED FOR OPERATION OF THE SYSTEM MUST BE INSTALLED CORRECTLY IN THE APPROPRIATE WELLS USING A SUITABLE THERMAL PASTE. POSITION PROBES B2 AND/OR B3 AT THE SAME HEIGHT WITH RESPECT TO THE MACHINE SUPPLY ACCUMULATION INLET.

13.8 INSTALLING THE VENTING VALVES



⚠ WARNING

IF THE MACHINE IS NOT INSTALLED AT THE HIGHEST POINT OF THE HEATING CIRCUIT, INSTALL ADDITIONAL VENTING VALVES AT A SUITABLE POINT.

13.9 CONNECTIONS

13.9.1 CONNECTION TO THE WATER ENERGY SOURCE



⚠ WARNING

TO PREVENT THE TRANSMISSION OF VIBRATIONS ON ADJACENT BUILDINGS, USE CONNECTING LINES TO THE MACHINE WITH A LENGTH OF AT LEAST **0.75 m** (s. **FIG. 37**).

IT IS MANDATORY TO INSULATE ALL PIPES TO REDUCE THERMAL DISPERSION AND AVOID CONDENSATE FORMATION.

IT IS MANDATORY FOR THE MACHINE TO ALWAYS BE POWERED IN ANTIFREEZE MODE IF THERE IS A RISK OF FREEZING. IF NECESSARY, MIX THE WATER WITH ETHYLENE OR PROPYLENE GLYCOL, CONSIDERING THAT THE PRESSURE DROPS ARE INCREASED.

IT IS MANDATORY TO CHECK THAT ALL THE COMPONENTS FITTED ARE COMPATIBLE WITH THE USE OF ETHYLENE OR PROPYLENE GLYCOL.

IT IS MANDATORY TO EMPTY THE PLANT COMPLETELY IN CASE OF LONG PERIODS OF MACHINE INACTIVITY.

Connect the delivery and return hoses as follows:

- 1) Unscrew and remove the cover caps (**FIG. 37 - Ref. 3**) from the delivery (**FIG. 37 - Ref. 5**) and return (**FIG. 37 - Ref. 4**) connections
- 2) Install a filter on the heating circuit between two shut-off valves
- 3) Install a flexible pipe (**FIG. 37 - Ref. 6**) with a gasket (**FIG. 37 - Ref. 2**) and a shut-off valve in the connection of the heating return to the building
- 4) Install a flexible pipe (**FIG. 37- Ref. 1**) with a gasket (**FIG. 37- Ref. 2**) and a shut-off valve in the connection of the heating supply to the heat pump
- 5) Check the connections for leaks
- 6) Cover the pipes with insulation (**FIG. 37 - Ref. 7**)



INFORMATION

DEPENDING ON THE MODEL AND SERIES OF THE MACHINE, THE FITTINGS VARY BETWEEN Ø 1" AND Ø 1" 1/2.

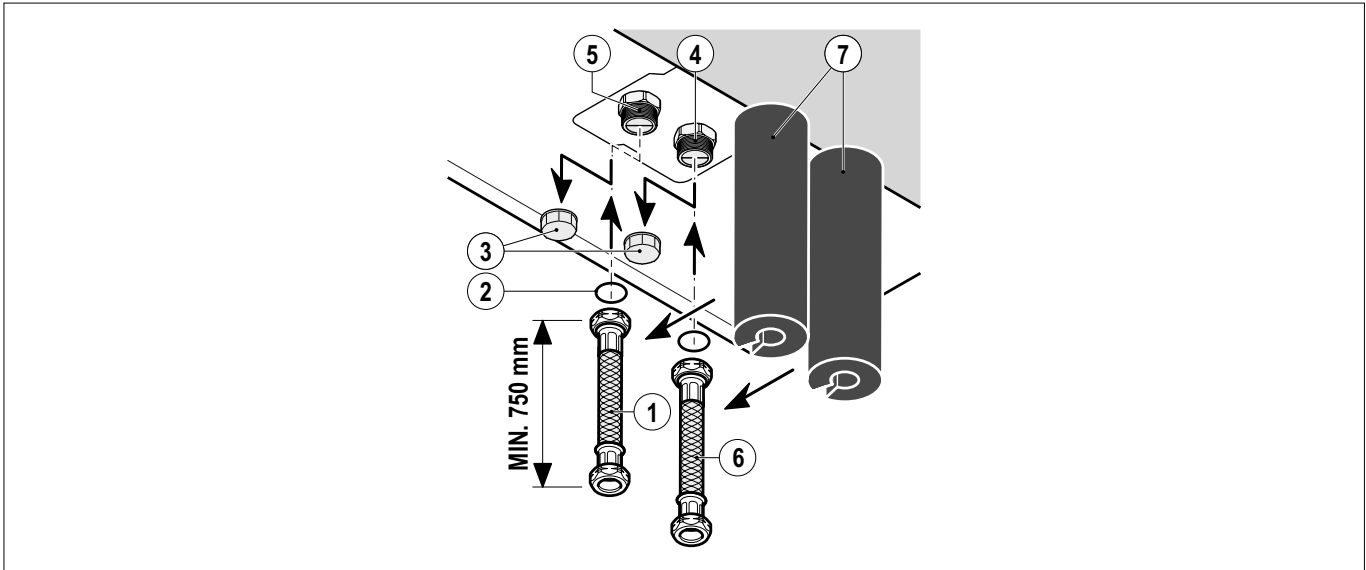

FIG. 42 (Connection to the water energy source)



⚠ WARNING

IT IS MANDATORY TO PROVIDE A **MINIMUM** VOLUME OF LITERS OF INITIAL ACCUMULATION WATER NECESSARY TO ENSURE THE OPERATION OF THE HEAT PUMP, EVEN IN THE DEFROSTING PHASES.



FIG. 43 (Transport safety)

13.9.2 CHOICE OF SYSTEM LAYOUT

Refer to the diagrams shown in the following pages for construction of the hydraulic system according to your needs and adapting it to the installation context.



⚠ WARNING

IT IS MANDATORY TO PROVIDE A MINIMUM VOLUME OF LITRES OF INERTIAL ACCUMULATION WATER TO ENSURE PROPER OPERATION OF THE HEAT PUMP, ALSO DURING DEFROSTING.

Series	Litres
HRP	300
SP-T	200
SP	200
MP	300
LP	500
LP PLUS	800
LR	500
LR PLUS	800
XS	200

TAB. 26 (MIN. litres of water with the use of puffers)



⚠ WARNING



















PROBE **B2** MUST BE POSITIONED AT THE TOP OF THE PUFFER, USING THE APPROPRIATE PROBE HOLDERS.



INFORMATION

THE DIAGRAMS SHOWN BELOW (**S. FIG. 39 AND FIG. 40**) ARE INTENDED PURELY AS EXAMPLES. THE MANUFACTURER CANNOT BE RESPONSIBLE FOR THE SYSTEM BUILT BY THE INSTALLER FOR ANY REASON.

THE SYSTEM MUST BE DESIGNED AND BUILT EXCLUSIVELY BY QUALIFIED PERSONNEL.

	antivibration flexible hose		signal cables
	water circulation pump		signal / power cables
	shut off valve		temperature probe
	filter		domestic hot water (DHW)
	expansion tank		manifold
	3 way valve		B2 buffer tank temperature probe
	automatic air vent		B3 DHW temperature probe
	relief safety valve		B4 inlet temperature probe
	check valve		B7 outlet temperature probe
	pressure reducing valve		

TAB. 27 (Key to system examples)

HEATING/COOLING PLANT + DHW WITH STORAGE TANK AS SEPARATOR

(* Alternative circulator to the internal circulator, powered and managed by T-Split card (FIG. 46 - Ref. 2, 3 and 6).

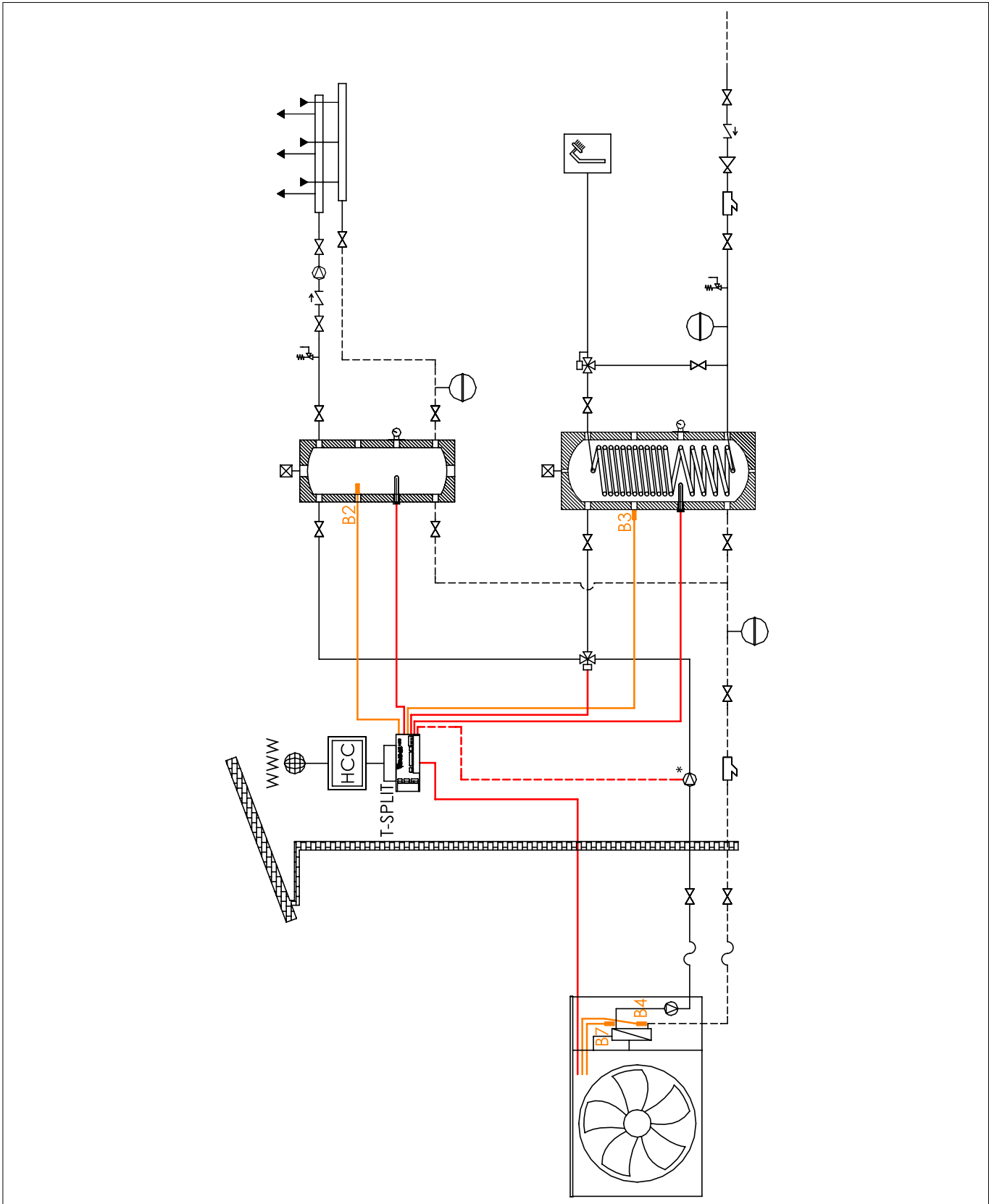

FIG. 44 (Heating/cooling plant + DHW with storage tank as separator)

HEATING/COOLING PLANT + DHW ("TEE" LAYOUT)

(*) Alternative circulator to the internal circulator, powered and managed by T-Split card (FIG. 46 - Ref. 2, 3 and 6).

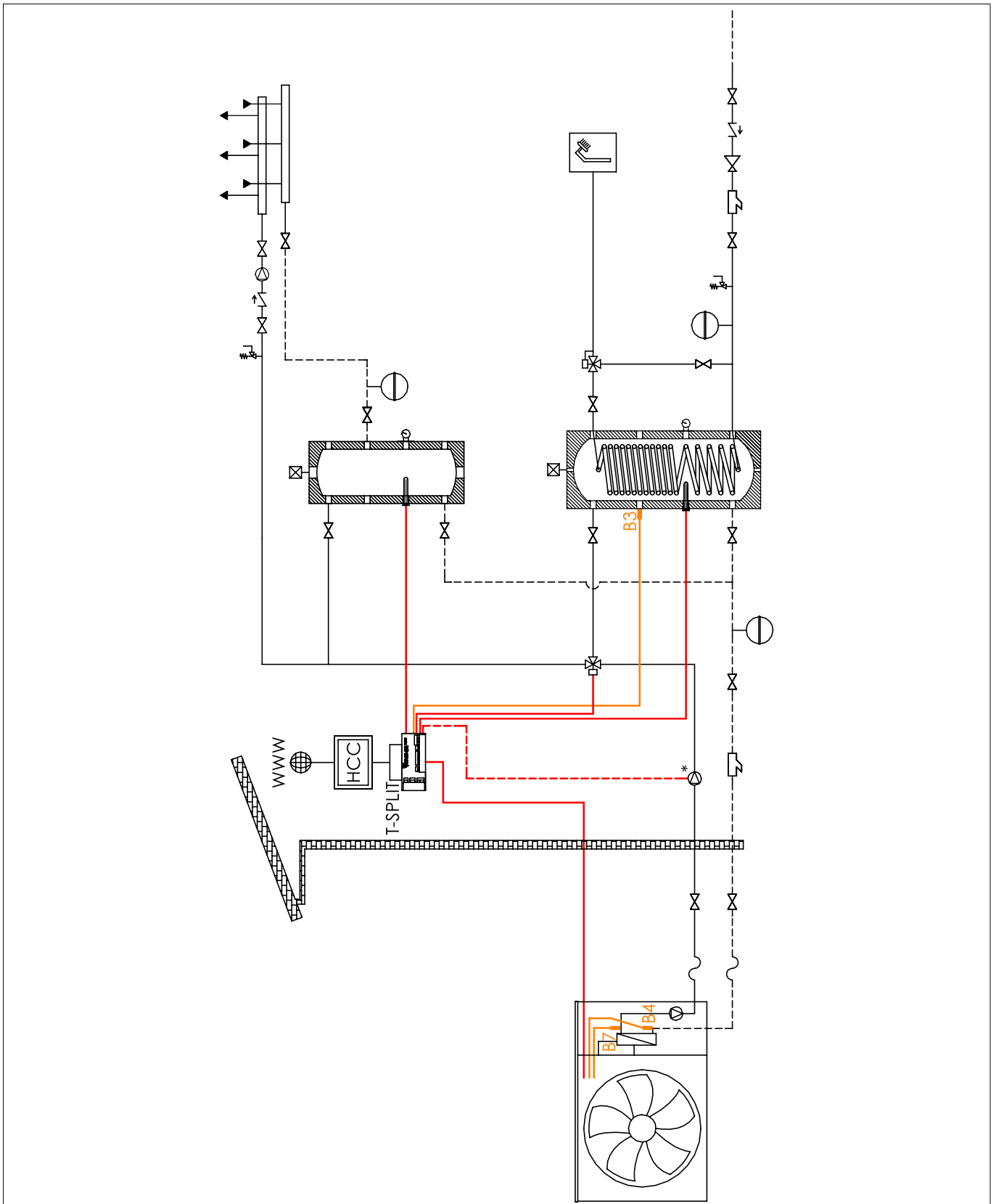

FIG. 45 (Heating/cooling plant + DHW - "TEE" layout)

EXAMPLE HEATING / COOLING SYSTEM XS MODEL WITH ARMCHAIR
with one direct and one mixed group.

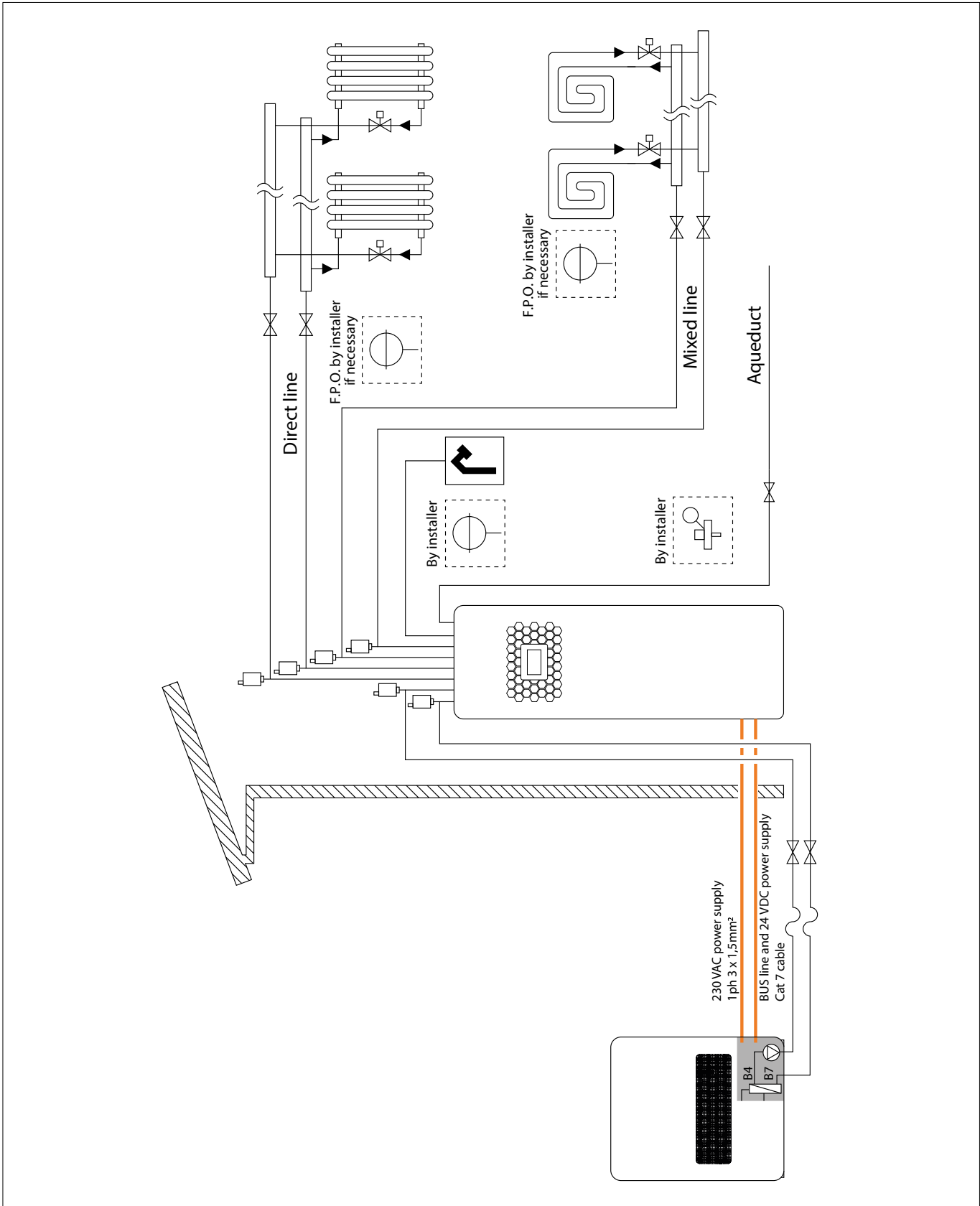

FIG. 46 (Heating/cooling + DHW system - "TEE" diagram)

13.9.3 CONNECTION TO THE ELECTRICAL ENERGY SOURCE



To connect the machine to the energy supply, proceed as follows:



⚠ DANGER

THE ELECTRICAL POWER FEEDING LINE TO WHICH THE MACHINE IS CONNECTED MUST BE IN COMPLIANCE WITH THE REQUIREMENTS OF STATUTORY LEGISLATION IN THE COUNTRY IN WHICH THE MACHINE IS PUT INTO SERVICE, BE EQUIPPED WITH A FUNCTIONAL PROTECTIVE EARTHING SYSTEM AND A RESIDUAL CURRENT DEVICE THAT DISCONNECTS THE POWER SUPPLY IF THE GROUND FAULT CURRENT EXCEEDS **30 mA** FOR **30 ms**, OR AN ADEQUATELY RATED ENERGY ISOLATING DEVICE IN RELATION TO THE MAX. POWER INPUT (**S. PAR. 5.7**).

IT IS MANDATORY TO CHECK THAT THE ELECTRICAL NETWORK CHARACTERISTICS (VOLTAGE, PHASES, FREQUENCY, POWER RATING) ARE COMPATIBLE WITH THE MACHINE (**S. PAR. 5.7**).



⚠ WARNING

THE MACHINE HOOK-UP TO THE ELECTRICAL POWER FEEDING NETWORK IS PERFORMED BY THE ELECTRICAL MAINTENANCE TECHNICIAN IN COMPLIANCE WITH THE DESIGN DATA AND IN CONFORMITY WITH THE ELECTRICAL SCHEMATIC SUPPLIED AS AN ANNEX TO THIS MANUAL (**S. PAR. 19.4**).

IT IS MANDATORY TO USE A SUITABLY RATED CONNECTION CABLE IN RELATION TO THE MACHINE'S POWER REQUIREMENTS (**S. PAR. 5.7**).



⚠ WARNING

ANY TYPE OF ELECTRICAL MATERIAL EMPLOYED TO MAKE THE CONNECTION MUST BE FIT FOR PURPOSE, "CE" MARKED AND IN COMPLIANCE WITH THE PRESCRIPTIONS OF STATUTORY LEGISLATION IN FORCE IN THE COUNTRY IN WHICH THE MACHINE IS PUT INTO SERVICE.



⚠ WARNING

IT IS MANDATORY TO LAY THE CABLES AT AN ADEQUATE DISTANCE FROM LINES WITH DIFFERENT VOLTAGES OR FROM DEVICES THAT MAY CREATE ELECTROMAGNETIC INTERFERENCE.

AVOID LAYING IN PARALLEL WITH OTHER CABLES. ONLY 90° LAYOUT IS ALLOWED.



⚠ WARNING

INSULATE THE WIRES (EVEN THOSE UNDERGROUND) BETWEEN THE MACHINE AND THE HEATING SYSTEM WITH UV AND HIGH TEMPERATURE RESISTANT INSULATION.



⚠ CAUTION

THE MANUFACTURER DECLINES ALL LIABILITY FOR MACHINE FAULTS OR OPERATING ANOMALIES CAUSED BY POWER SUPPLY SURGES OR DIPS EXCEEDING THE ELECTRICITY COMPANY'S STATED TOLERANCE VALUES ($\pm 5\%$ VOLTAGE, $\pm 2\%$ FREQUENCY).



INFORMATION

USE A FERRITE TOROID TO PROTECT THE REMOTE PANEL FROM ANY EXTERNAL DISTURBANCES.

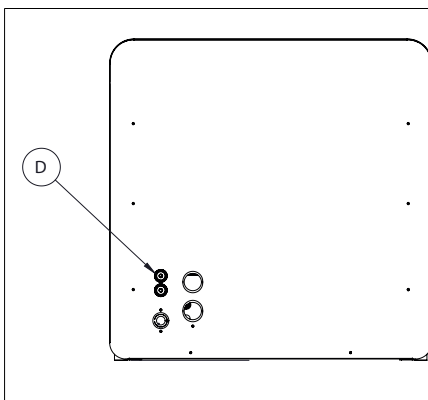

SCHEMA COLLEGAMENTO ALLA FONTE DI ENERGIA ELETTRICA SERIRE XS

D= PASSAGGIO CAVI ELETTRICI

13.9.4 INSTALLATION OF THE XS HIGH VERSION HEAT PUMP

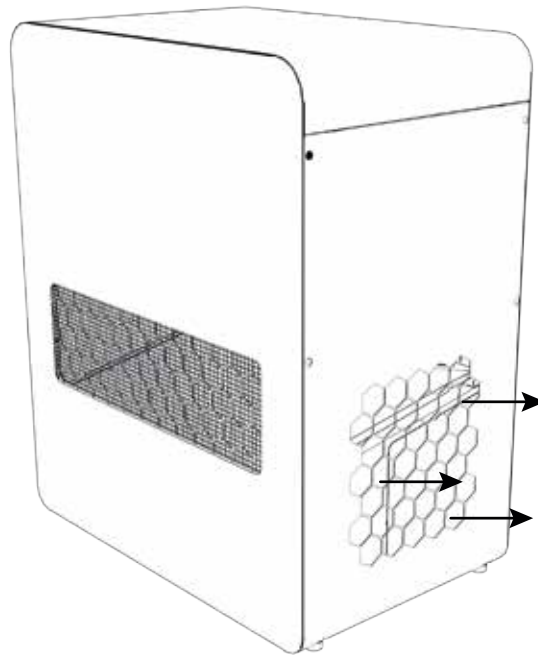

HIGH VERSION INSTALLATION NOTES
- Outlet on the side

13.9.5 MINIMUM CLEARANCES FOR HEAT PUMP INSTALLATION - XS HIGH VERSION

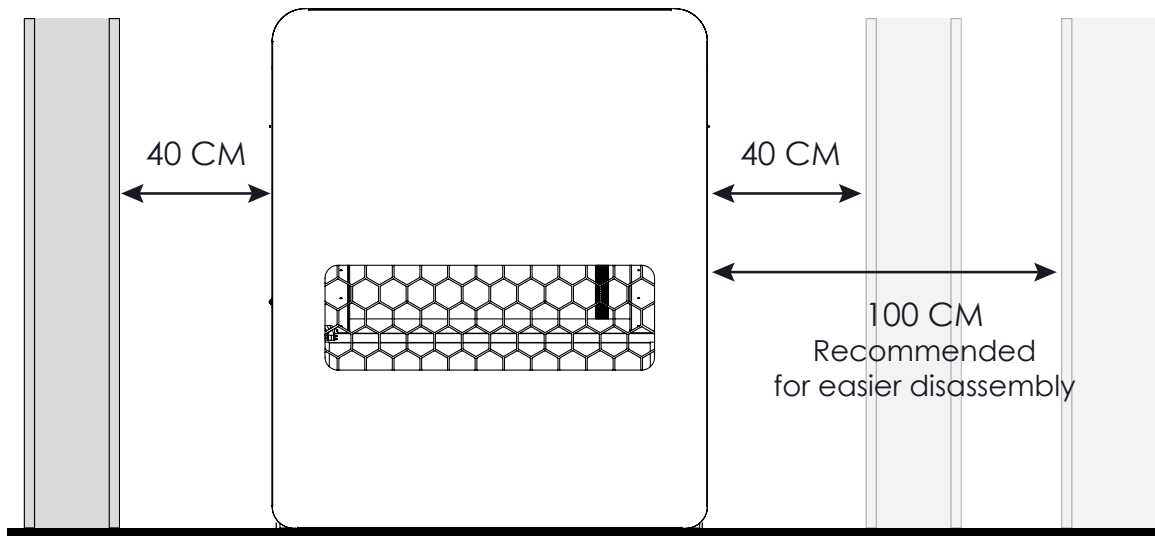

- LH clearance 40cm
- RH clearance 40÷100cm

13.9.6 INSTALLATION OF UTILITIES (HEAT PUMP SUPPLY/RETURN, ELECTRICAL WIRING, CONDENSATE OUTLET)

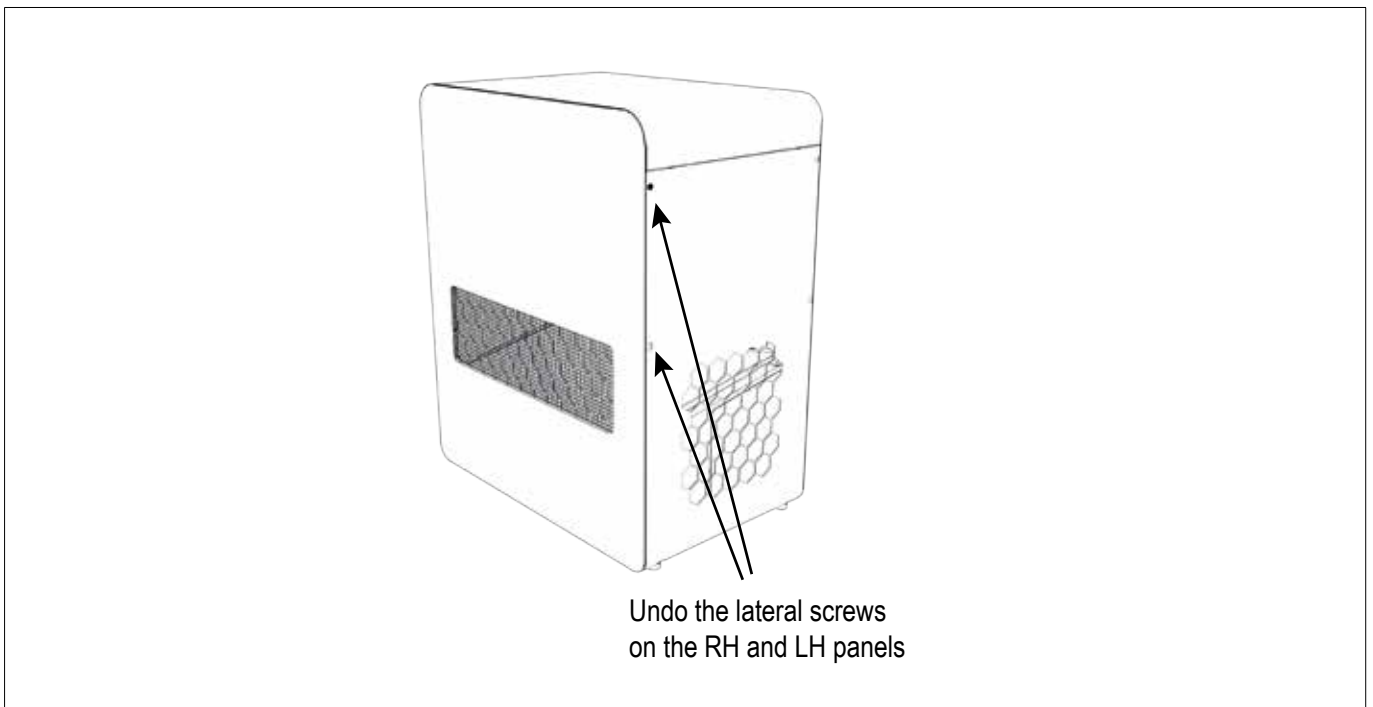

REMOVE THE EXTERNAL SECTION IN THE FOLLOWING ORDER:

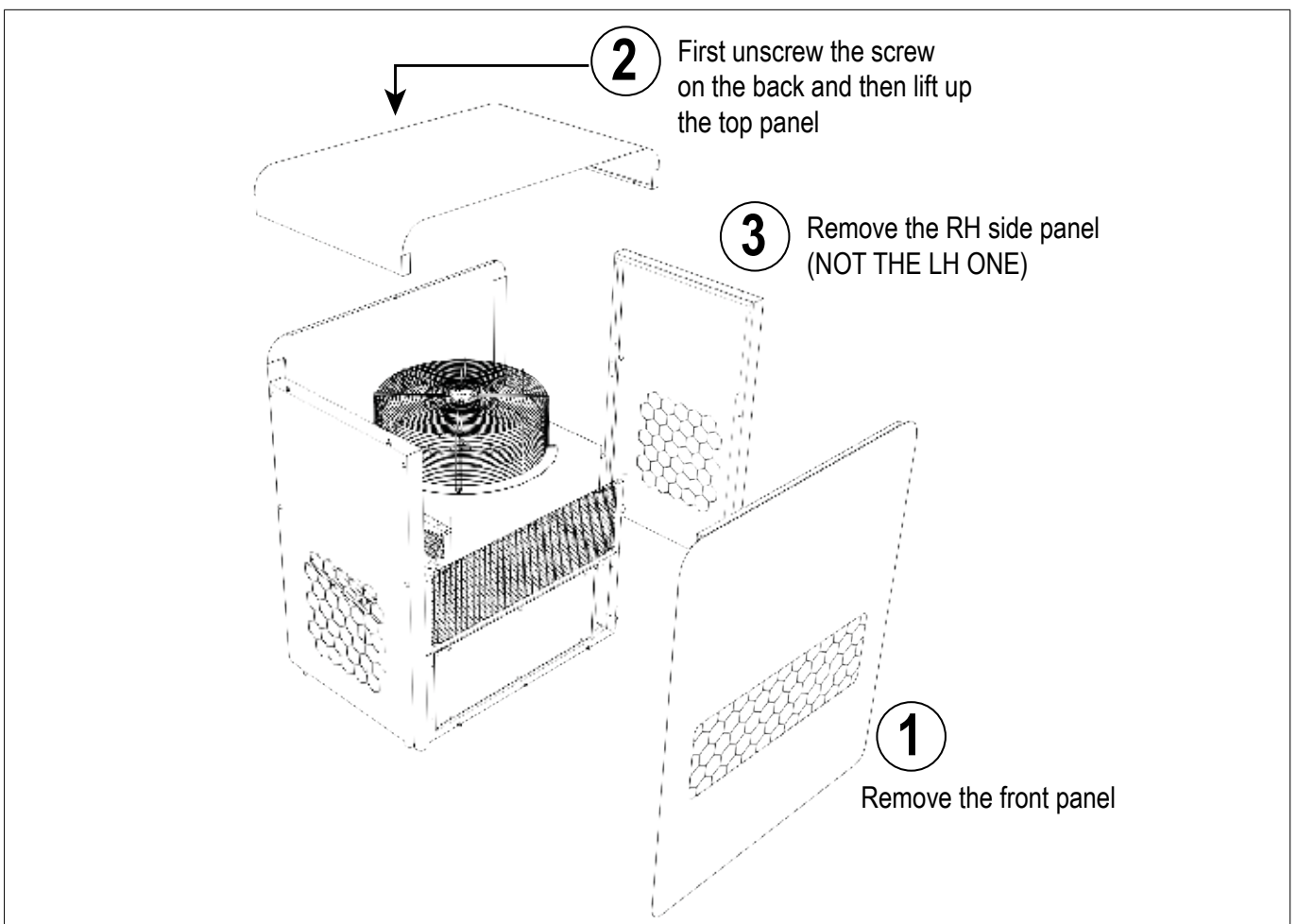

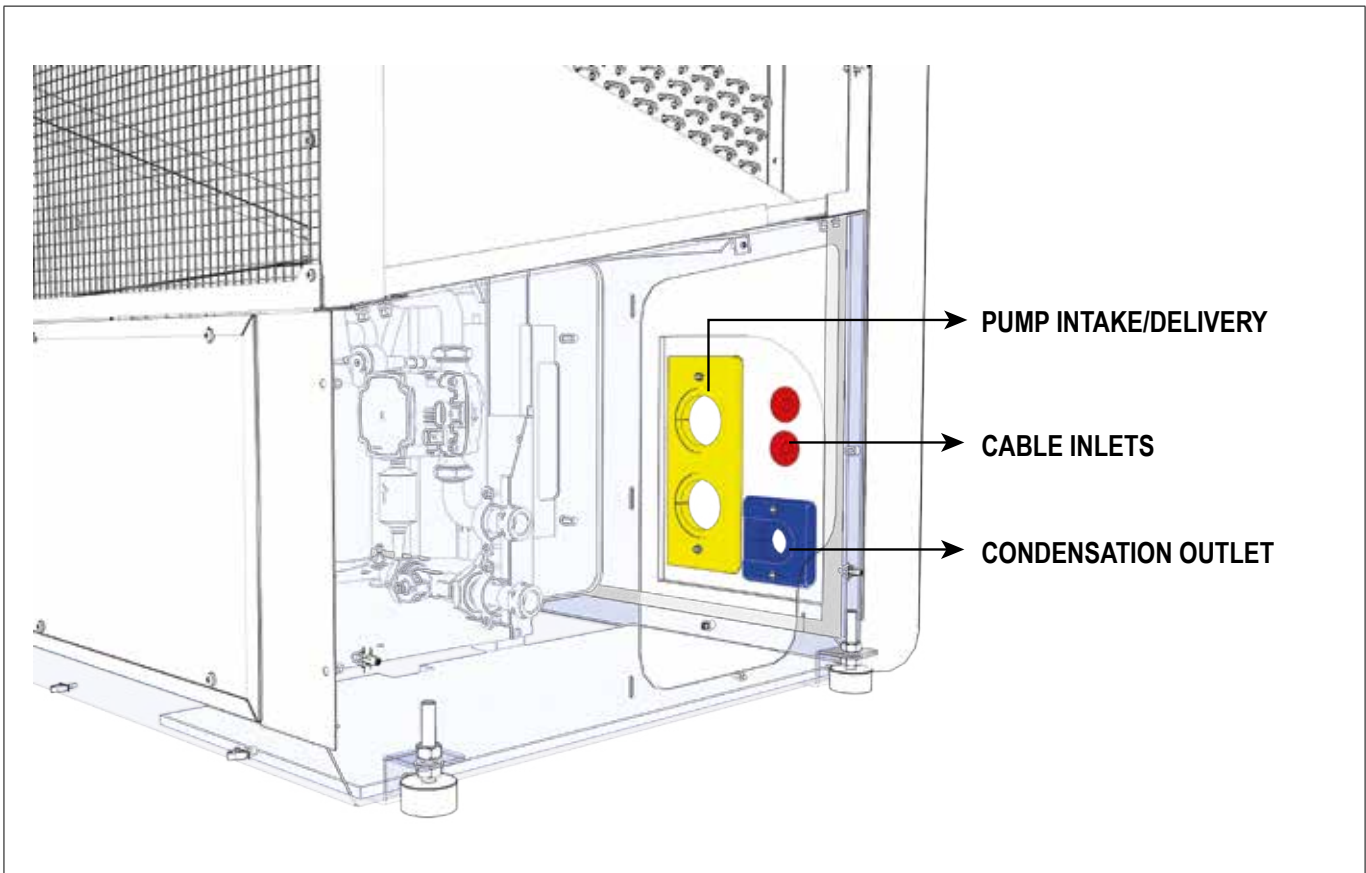
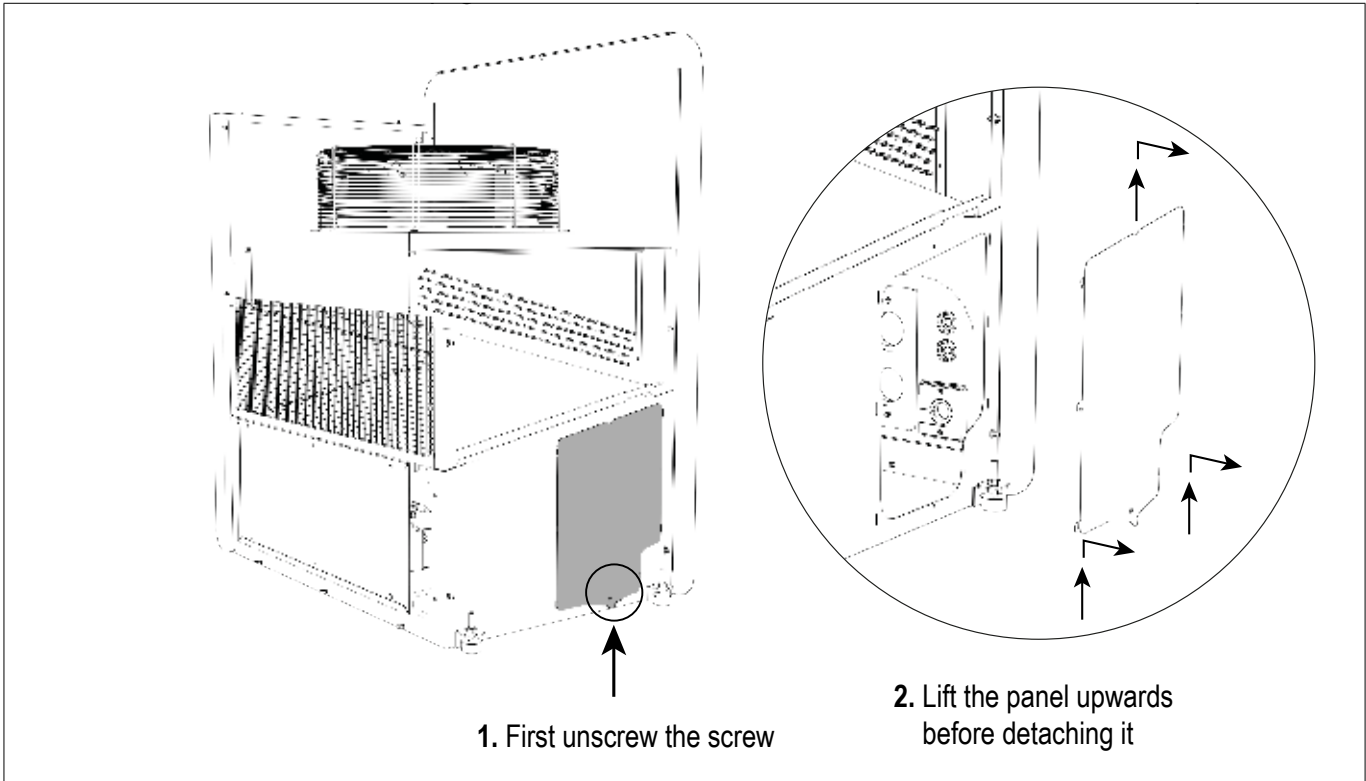

CAUTION

BEFORE LOCATING THE HEAT PUMP AGAINST THE WALL, ARRANGE THE SERVICE OUTLETS ON THE BACK PANEL

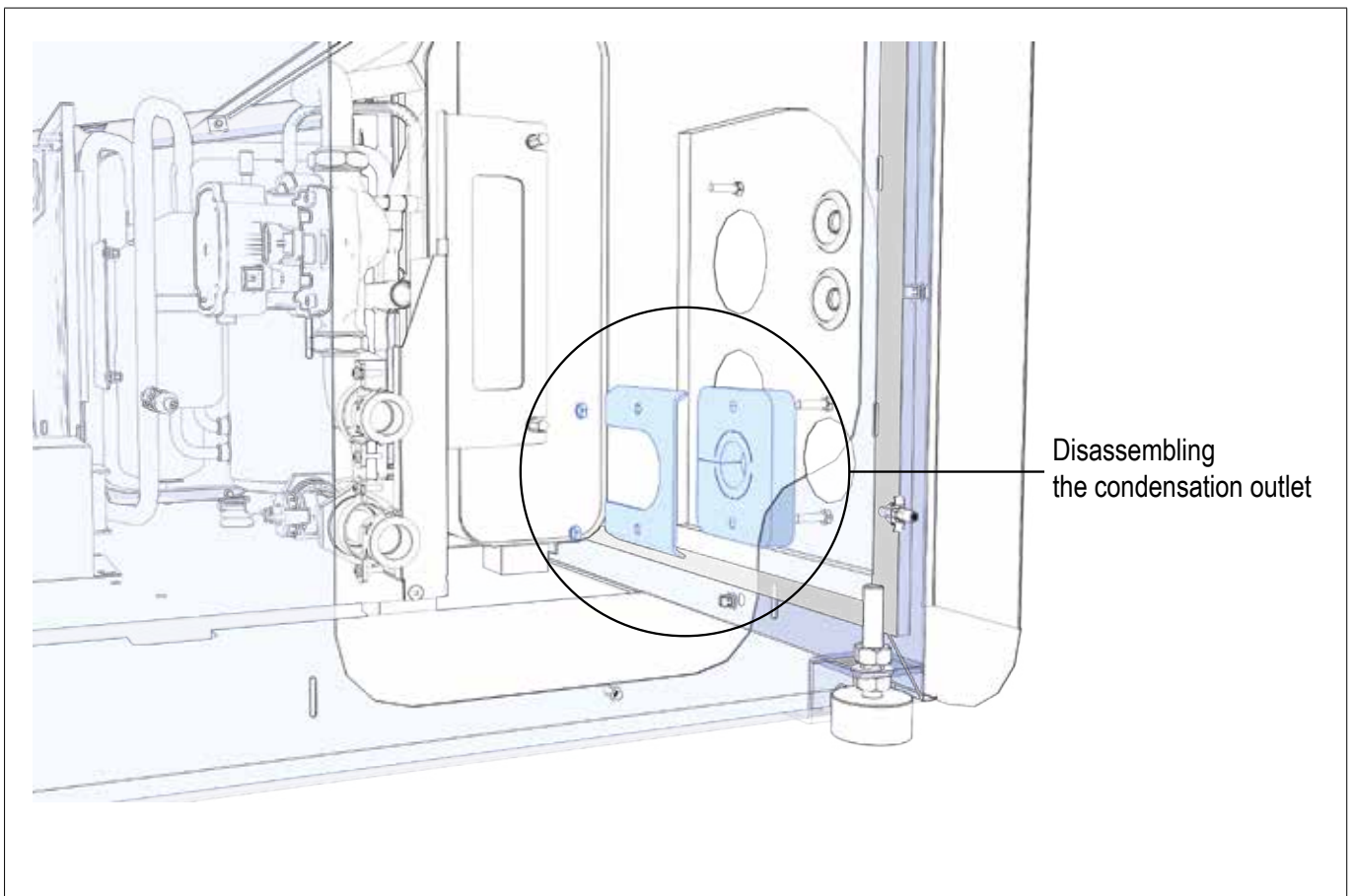
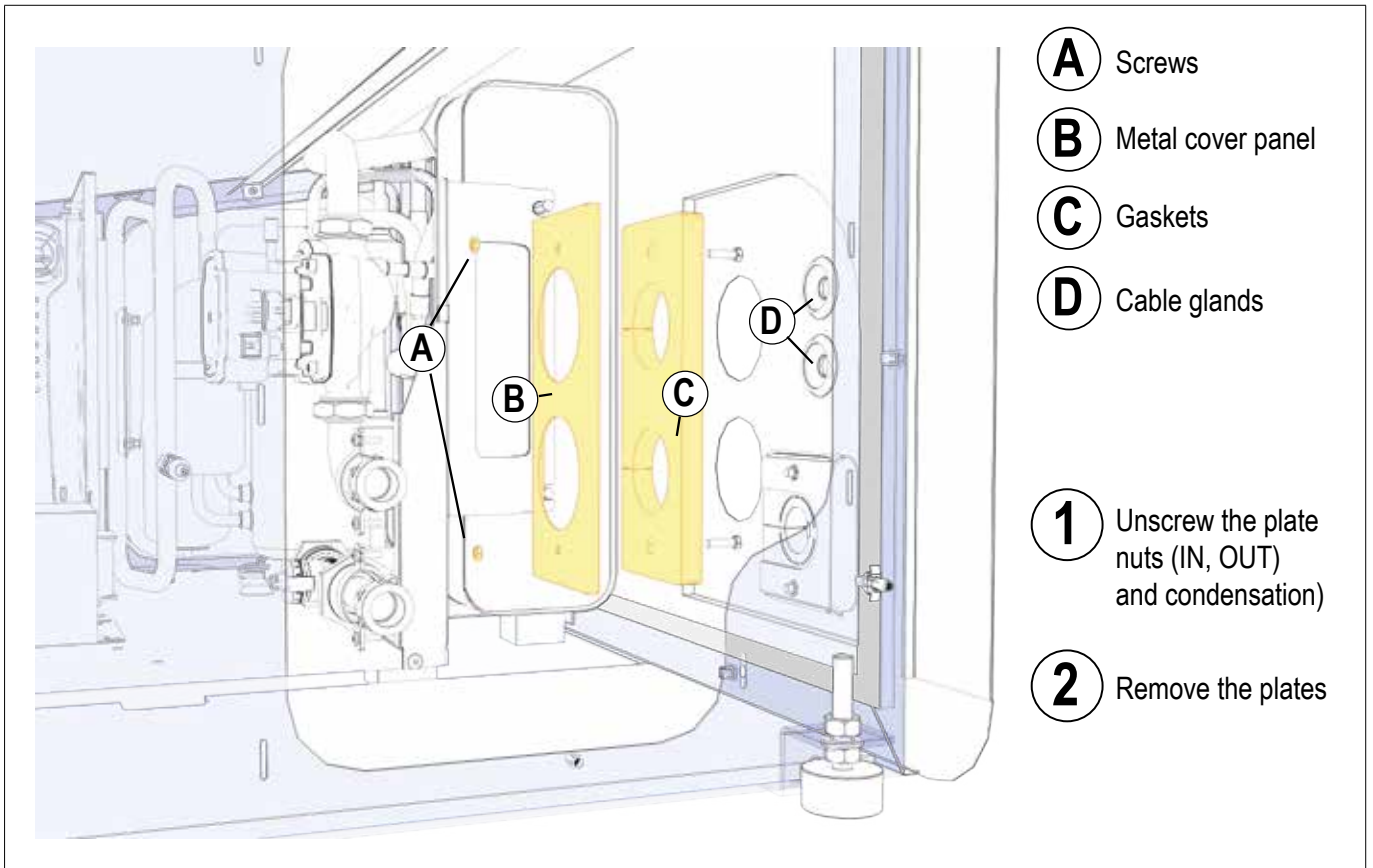

Locate the heat pump against the wall, making sure to route the service hoses as shown in the following figure.

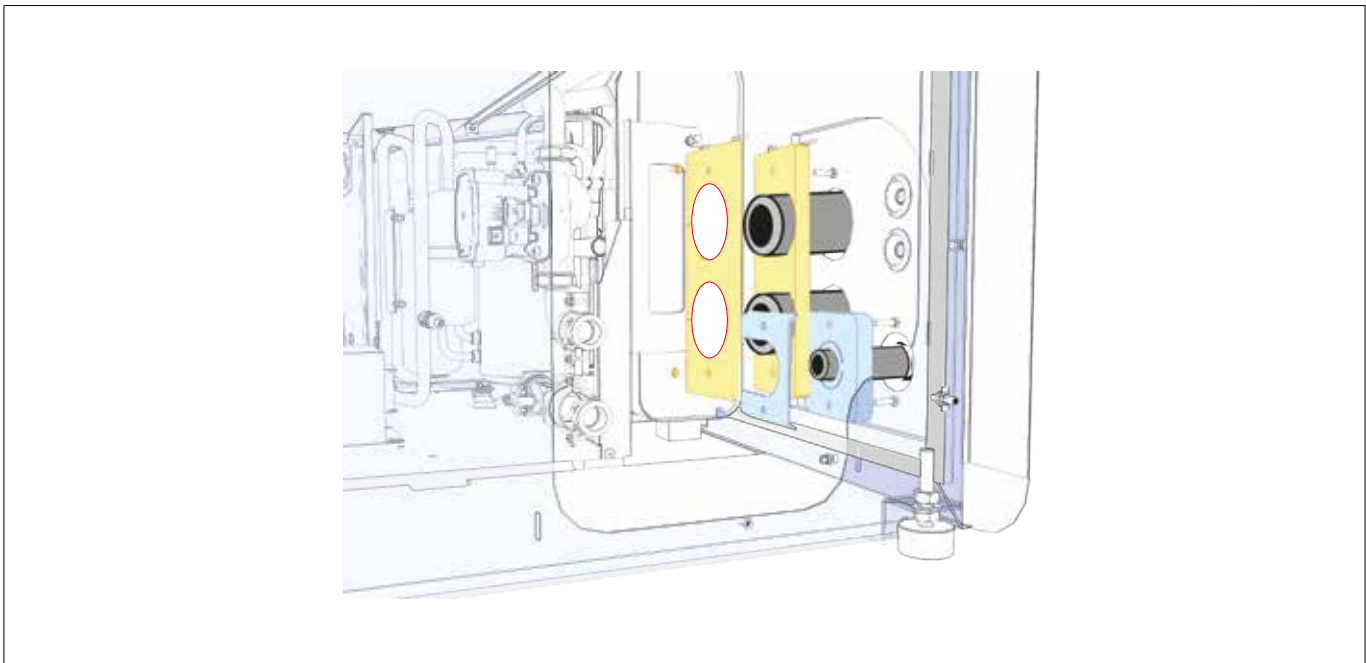
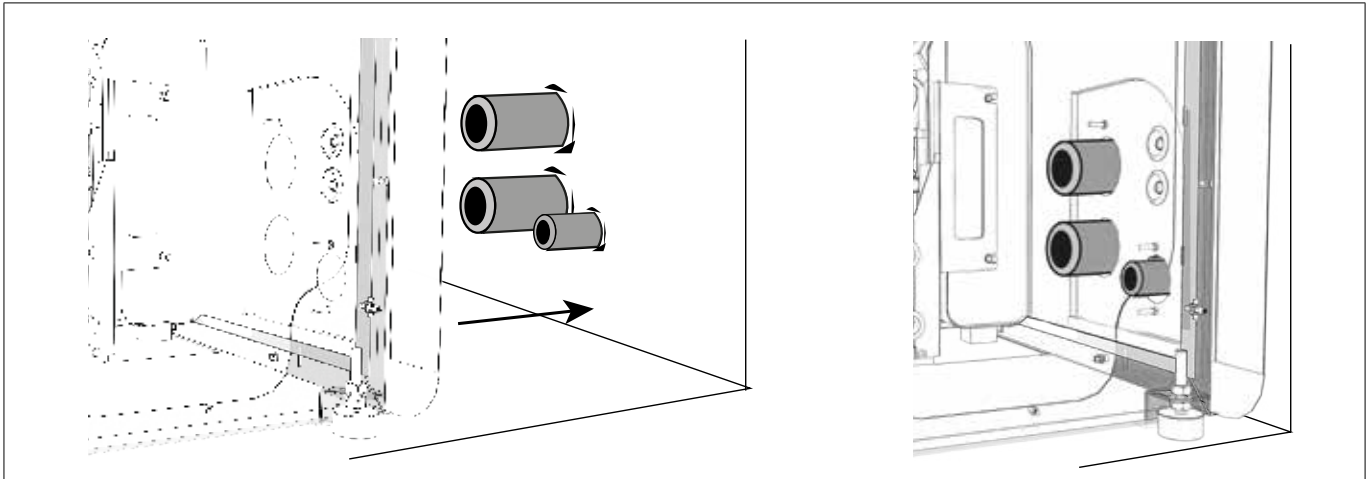

⚠ CAUTION



CAUTION: ONCE THE HOSES RUNNING FROM THE WALL INTO THE MACHINE ARE IN POSITION, FIT THE GASKET AND PLATE (IN THAT ORDER) BEFORE MAKING ANY OTHER CONNECTIONS. THEN SECURE THEM BY TIGHTENING DOWN THE NUTS TO COMPRESS THE GASKET AROUND THE HOSES.

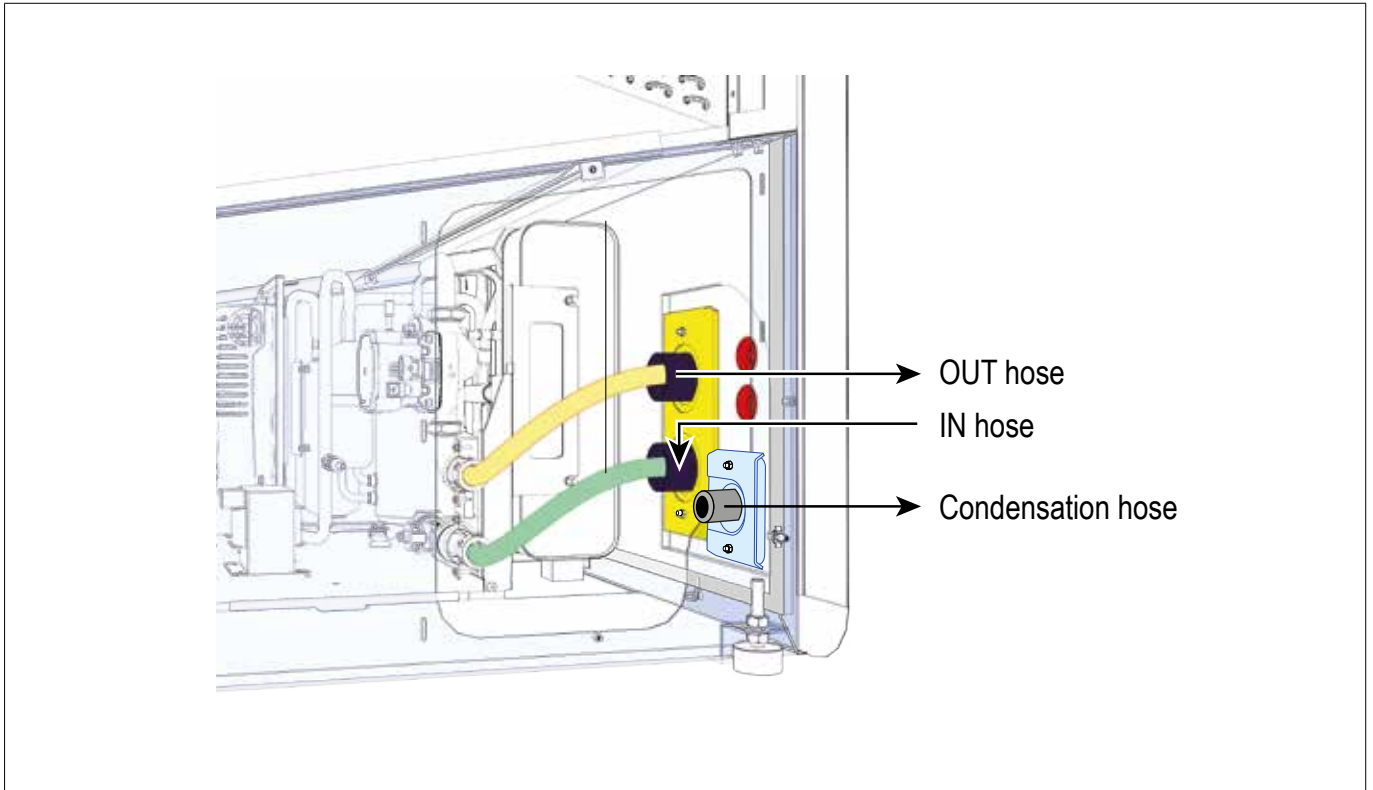

⚠ WARNING



COMPLETE THE WATER CIRCUIT HOOKUP WITH TWO HOSES

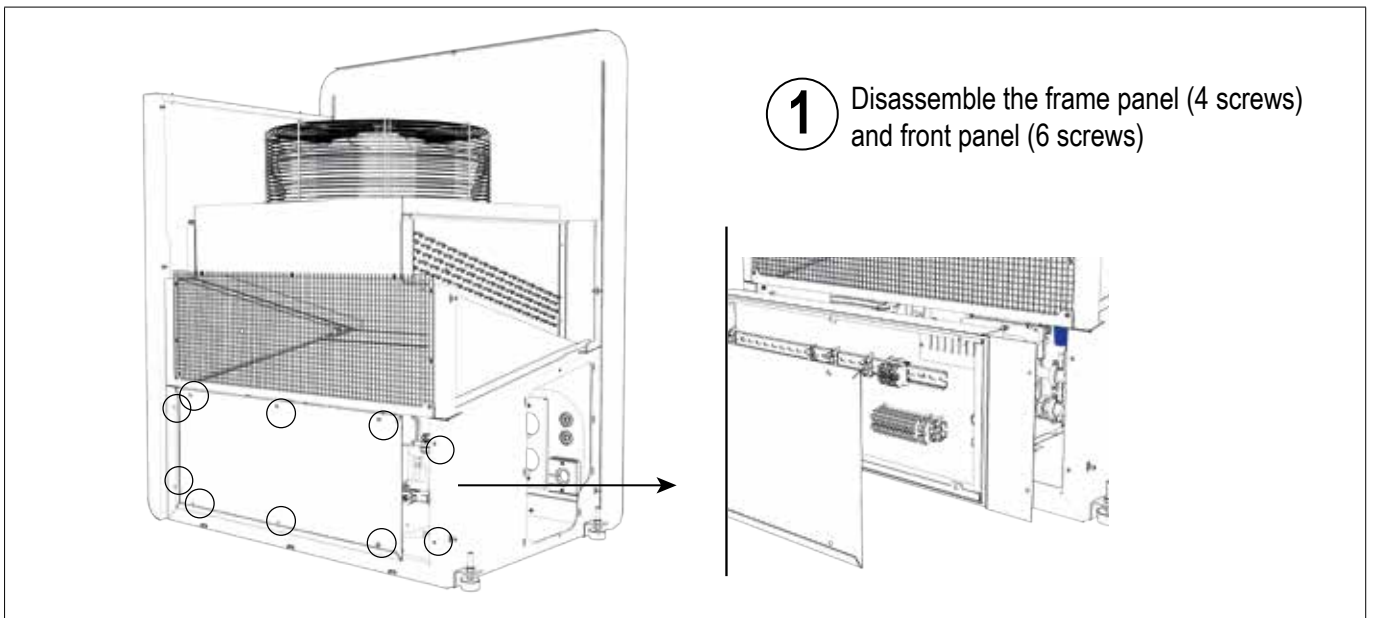

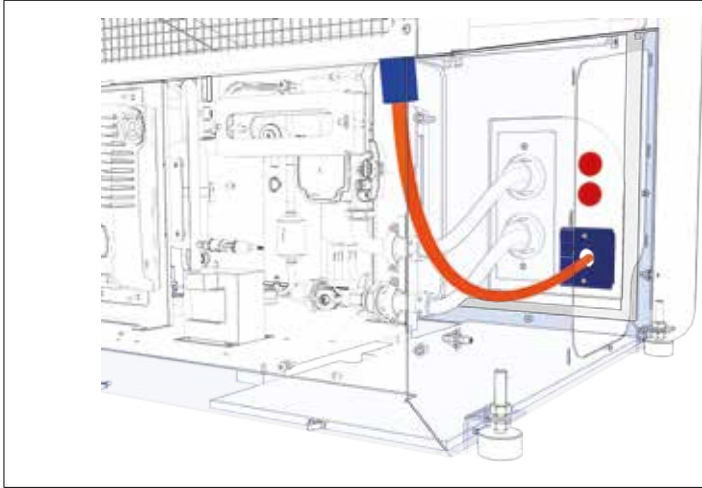

- 2** Connect the condensation hose to the hose on the tray to the right (secure with a clamp)

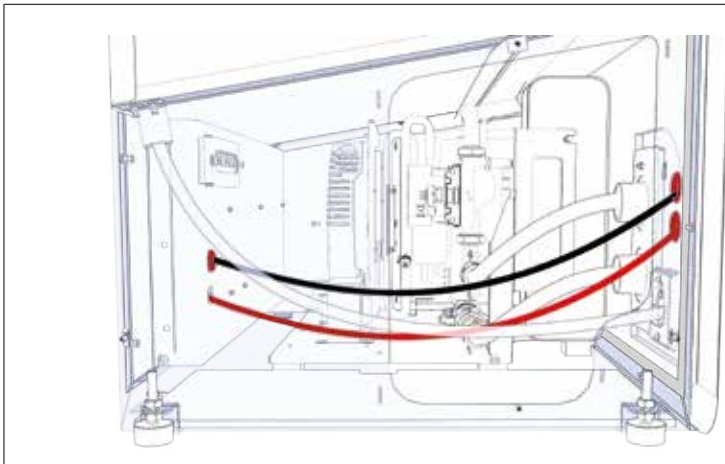

- 3** Route the data and power cables through the cable glands and secure them to the terminal block (see electrical section)

Reassemble everything (in reverse order).

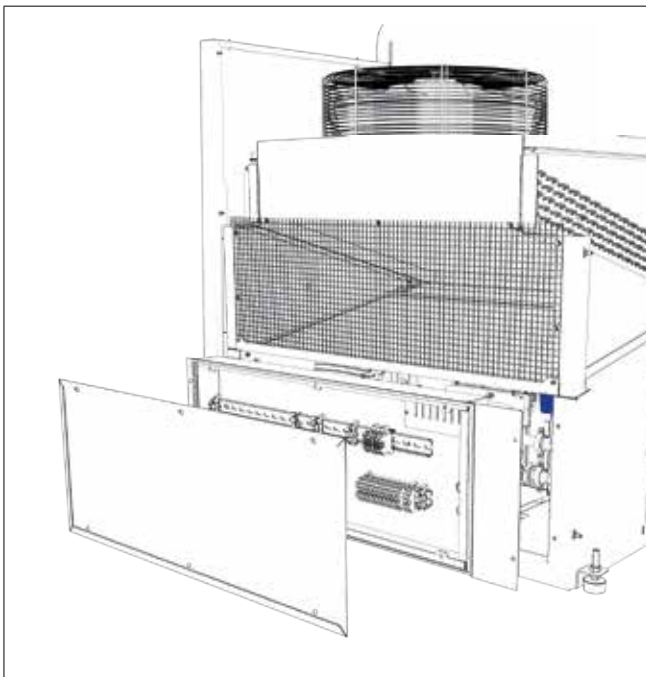

- 1** Install the frame panel (4 screws) and front panel (6 screws)

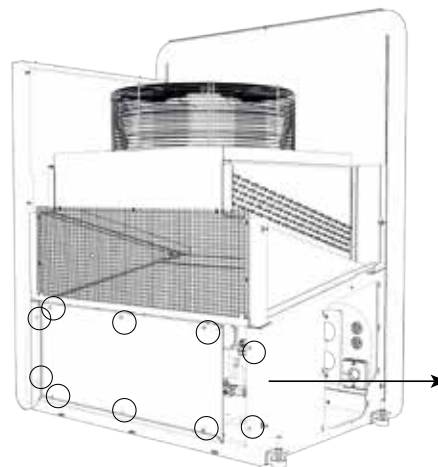

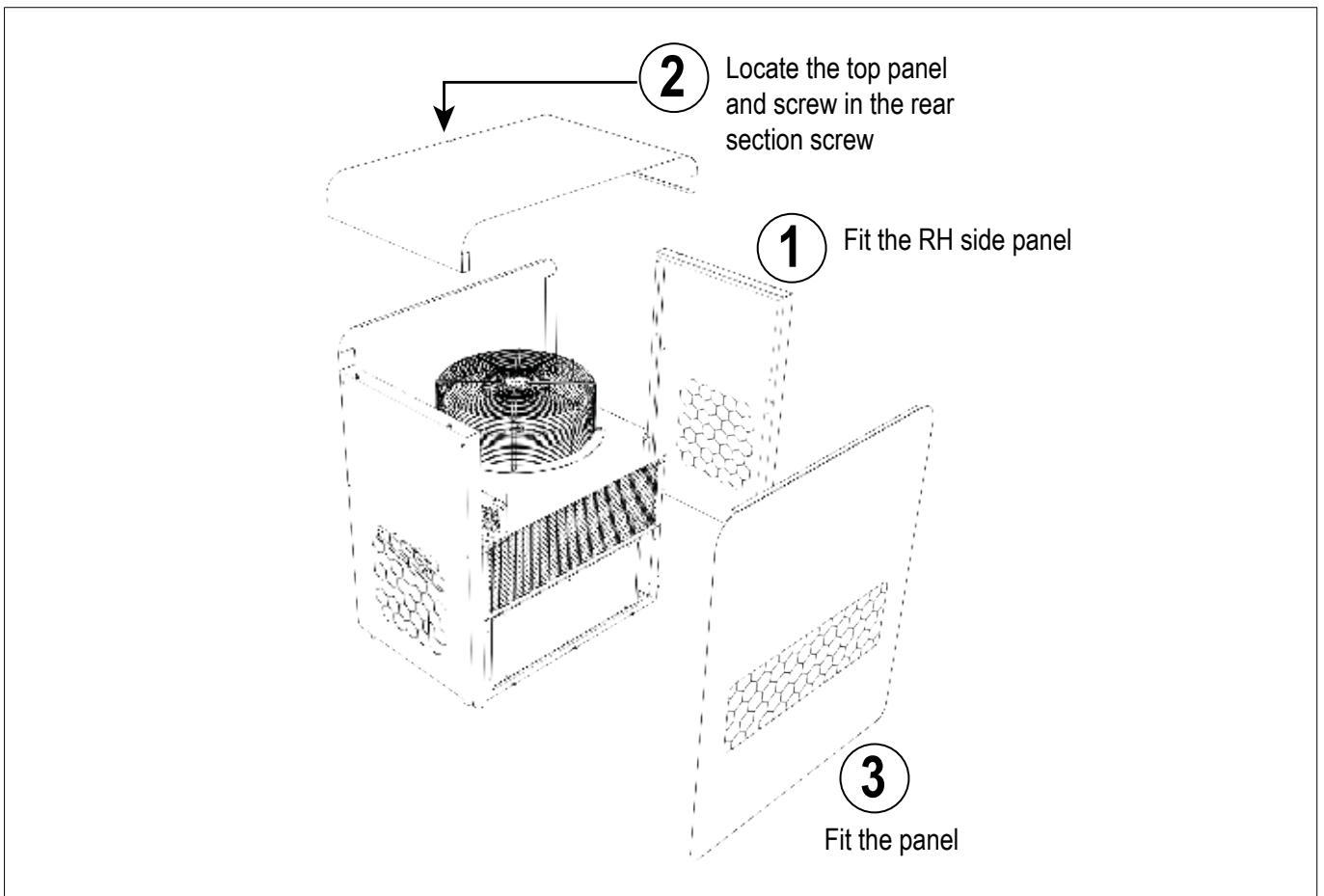
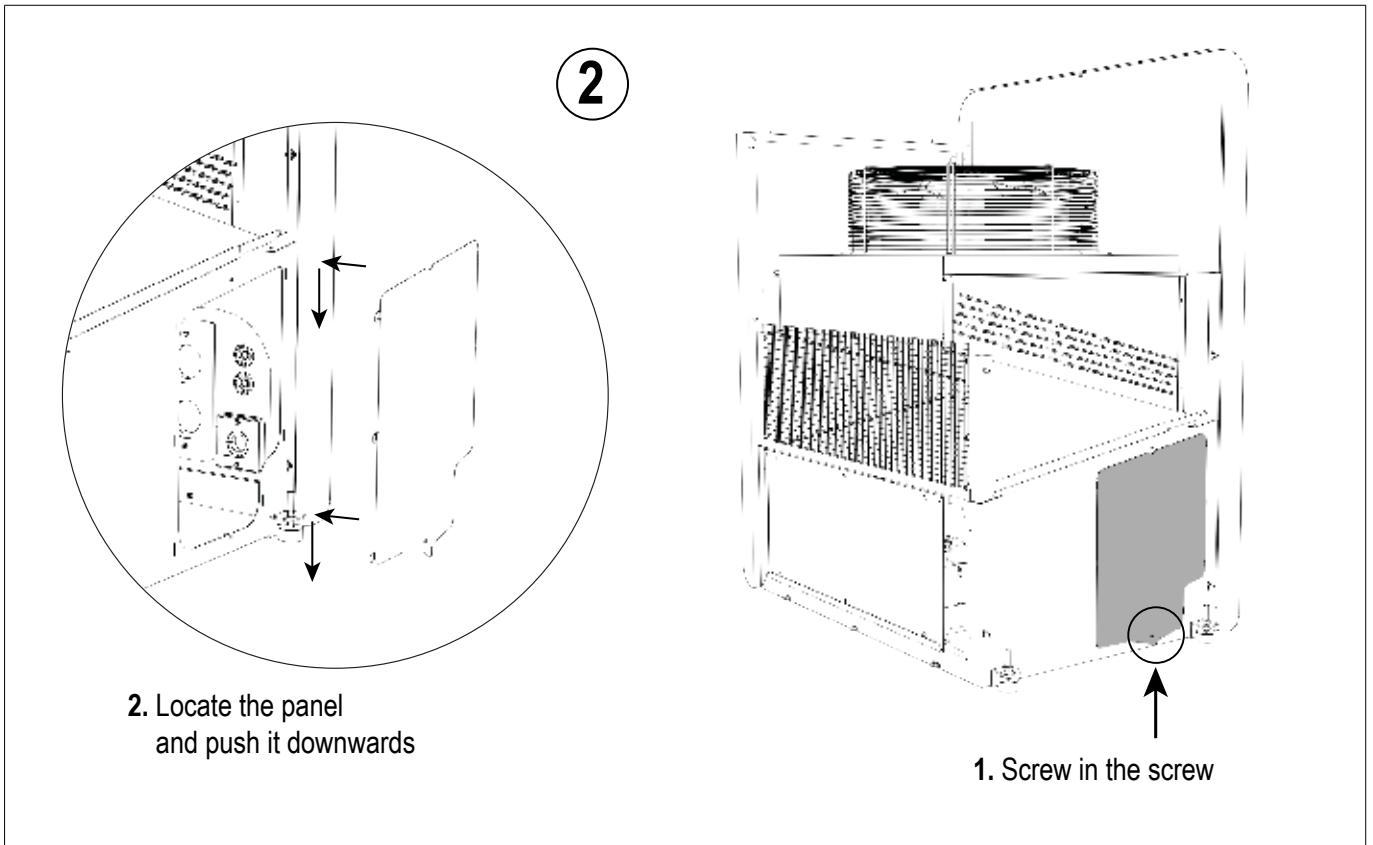

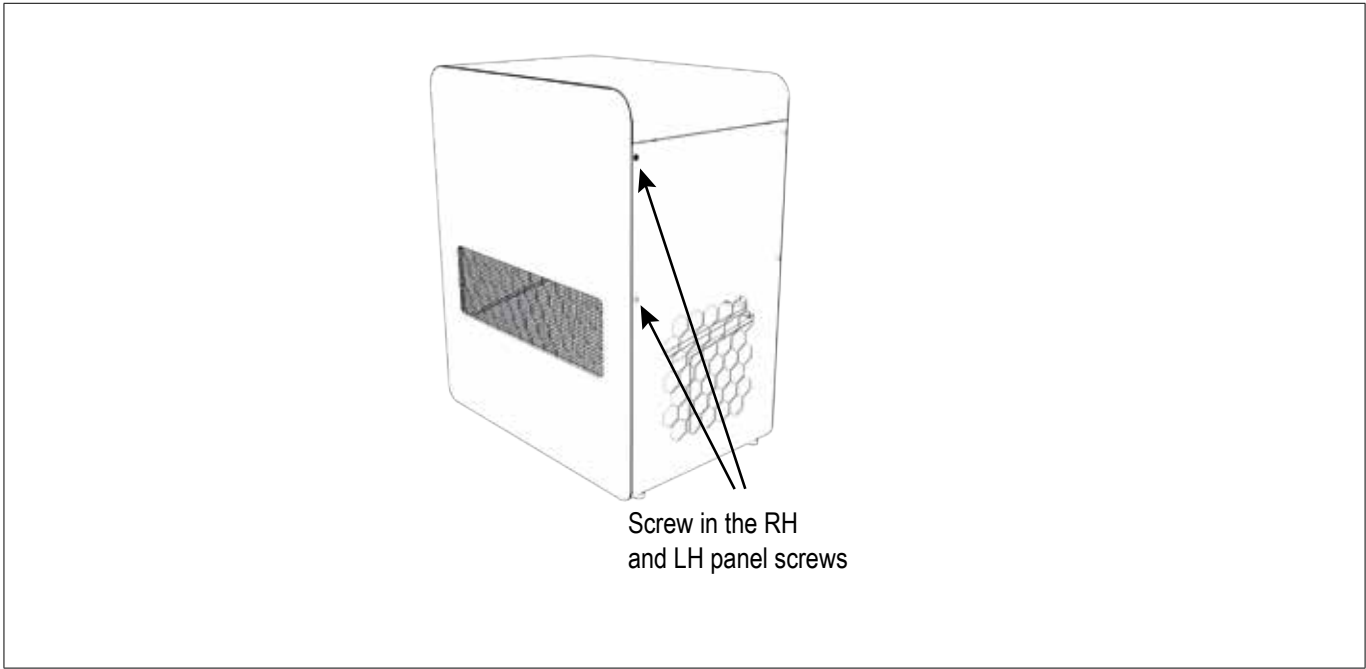

CAUTION

IF THE RH SIDE IS NOT EASILY ACCESSIBLE, THE HOOKUP CAN BE DONE FROM THE FRONT.

Remove the lateral screws on the two panels and the remove only the front panel

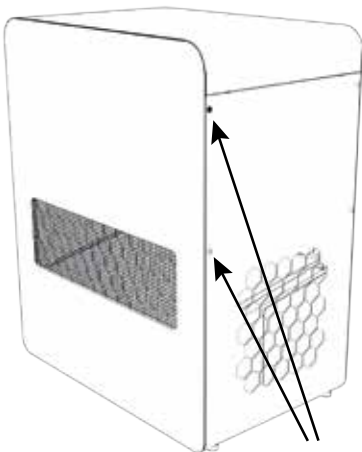

Undo the lateral screws on the RH and LH panels

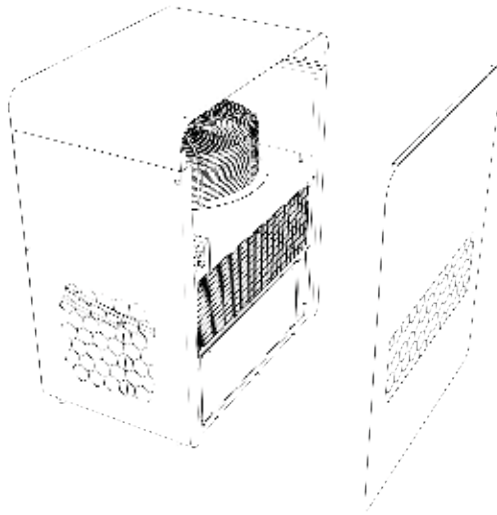

1

Remove the front panel

The disassembly procedure is as follows:

- Disassemble the electrical panel
- Disassemble the tray
- Disassemble the grille

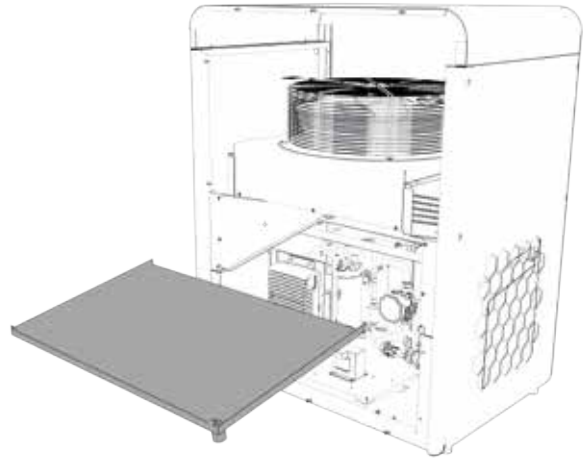
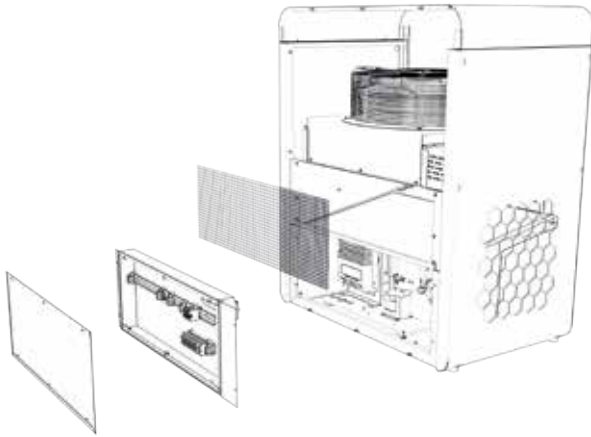

⚠ WARNING



THE HOOKUP PROCEDURE IS SIMILAR TO BEFORE. LOCATE THE HEAT PUMP AGAINST THE WALL AND HOOK UP THE SERVICES. ONCE EVERYTHING IS HOOKED UP, RESTORE THE GRILLE, TRAY AND PANEL.

13.9.7 INSTALLATION OF THE XS LOW VERSION HEAT PUMP

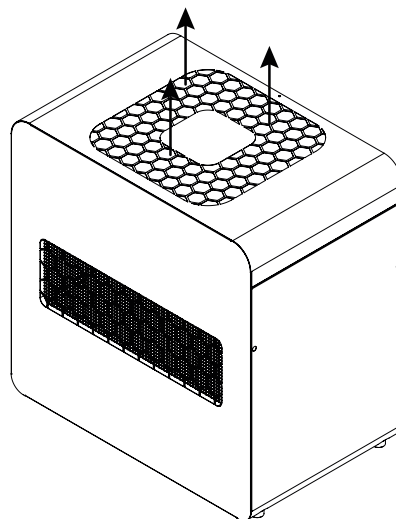

LOW VERSION INSTALLATION NOTES
- Outlet on the side

13.9.8 MINIMUM CLEARANCES FOR HEAT PUMP INSTALLATION XS LOW VERSION

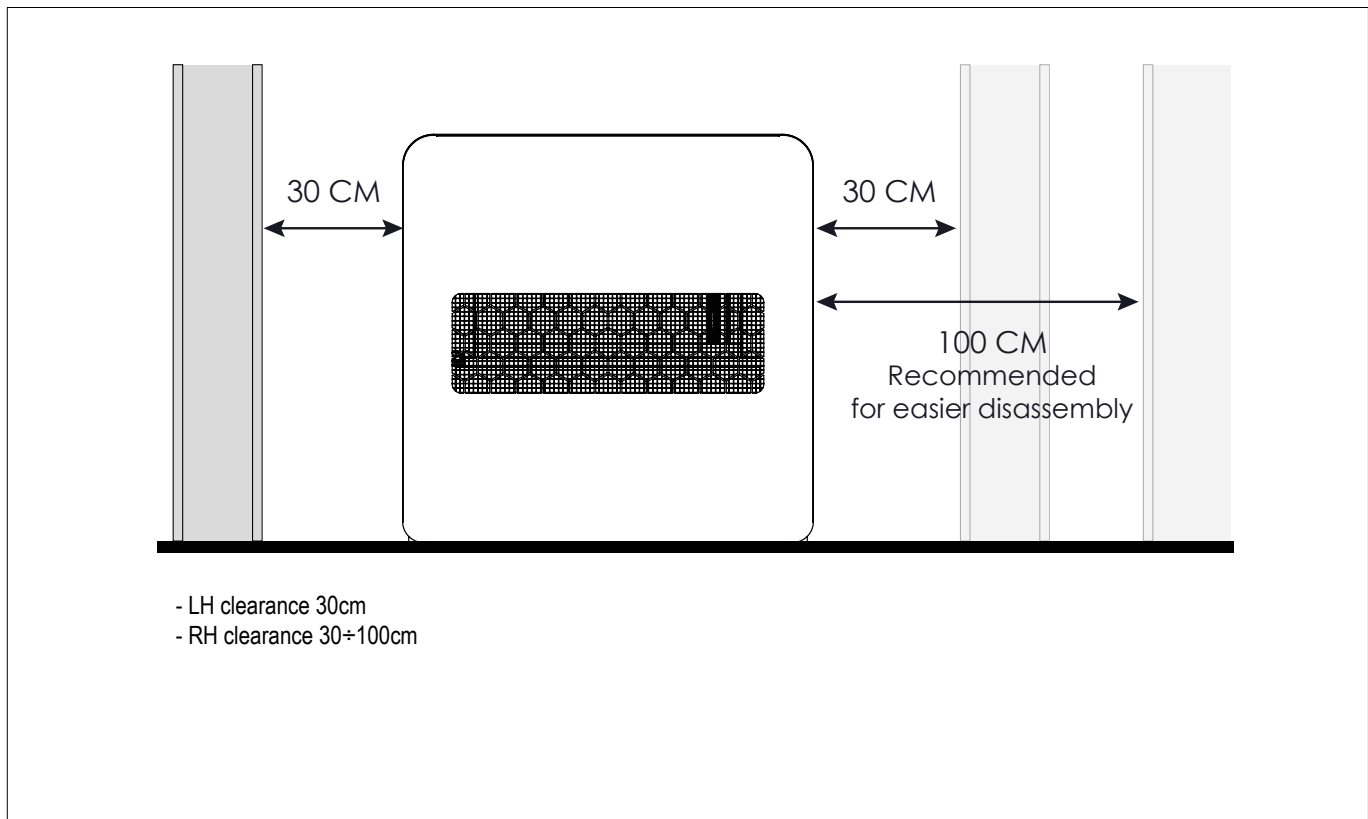

13.9.9 INSTALLATION OF UTILITIES (HEAT PUMP SUPPLY/RETURN, ELECTRICAL WIRING, CONDENSATE OUTLET)

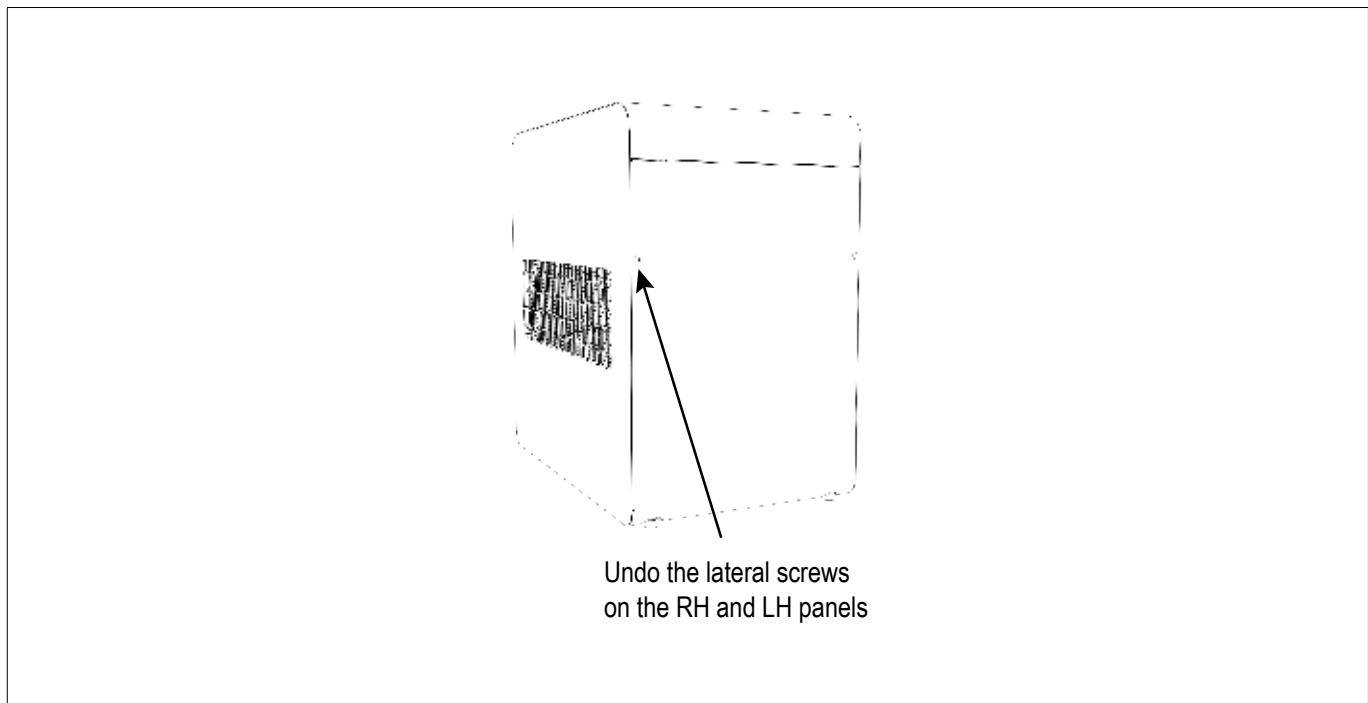

REMOVE THE EXTERNAL SECTION IN THE FOLLOWING ORDER.

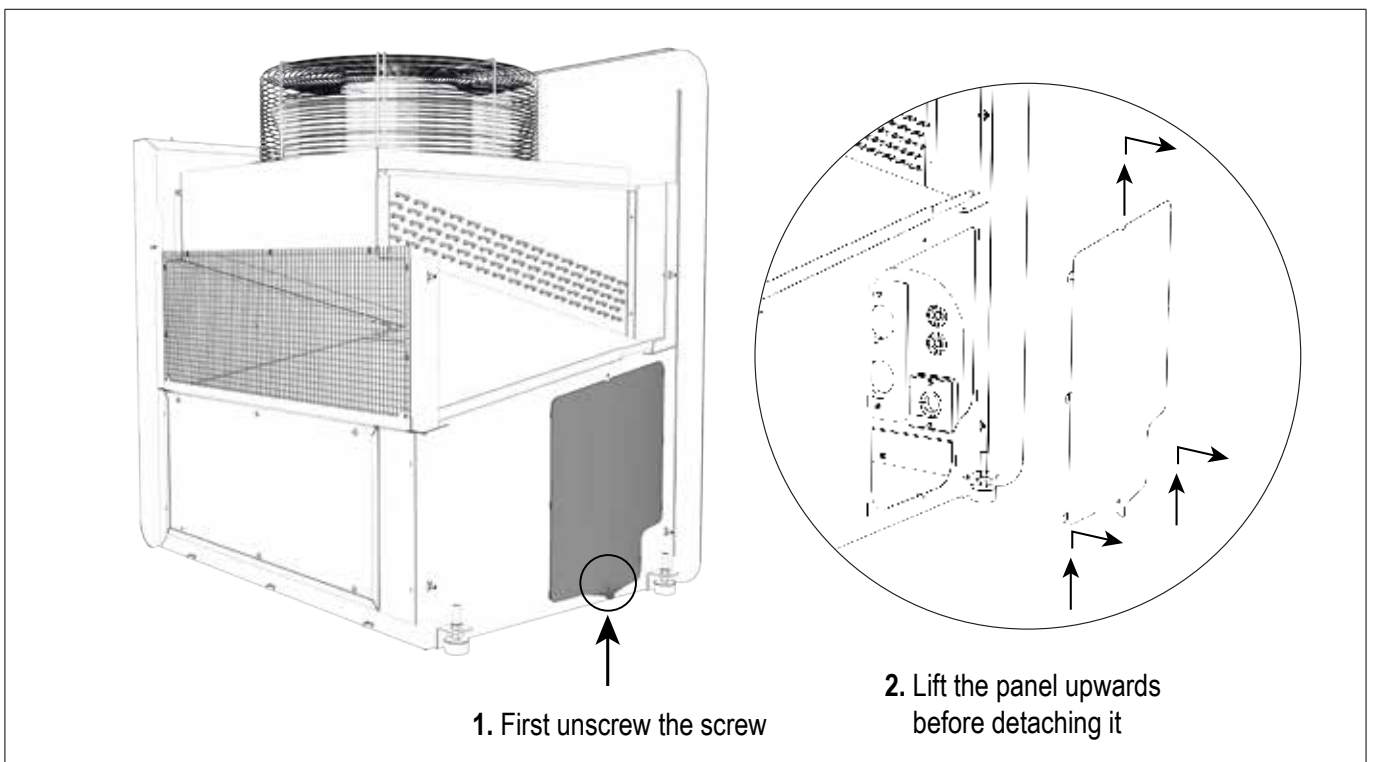
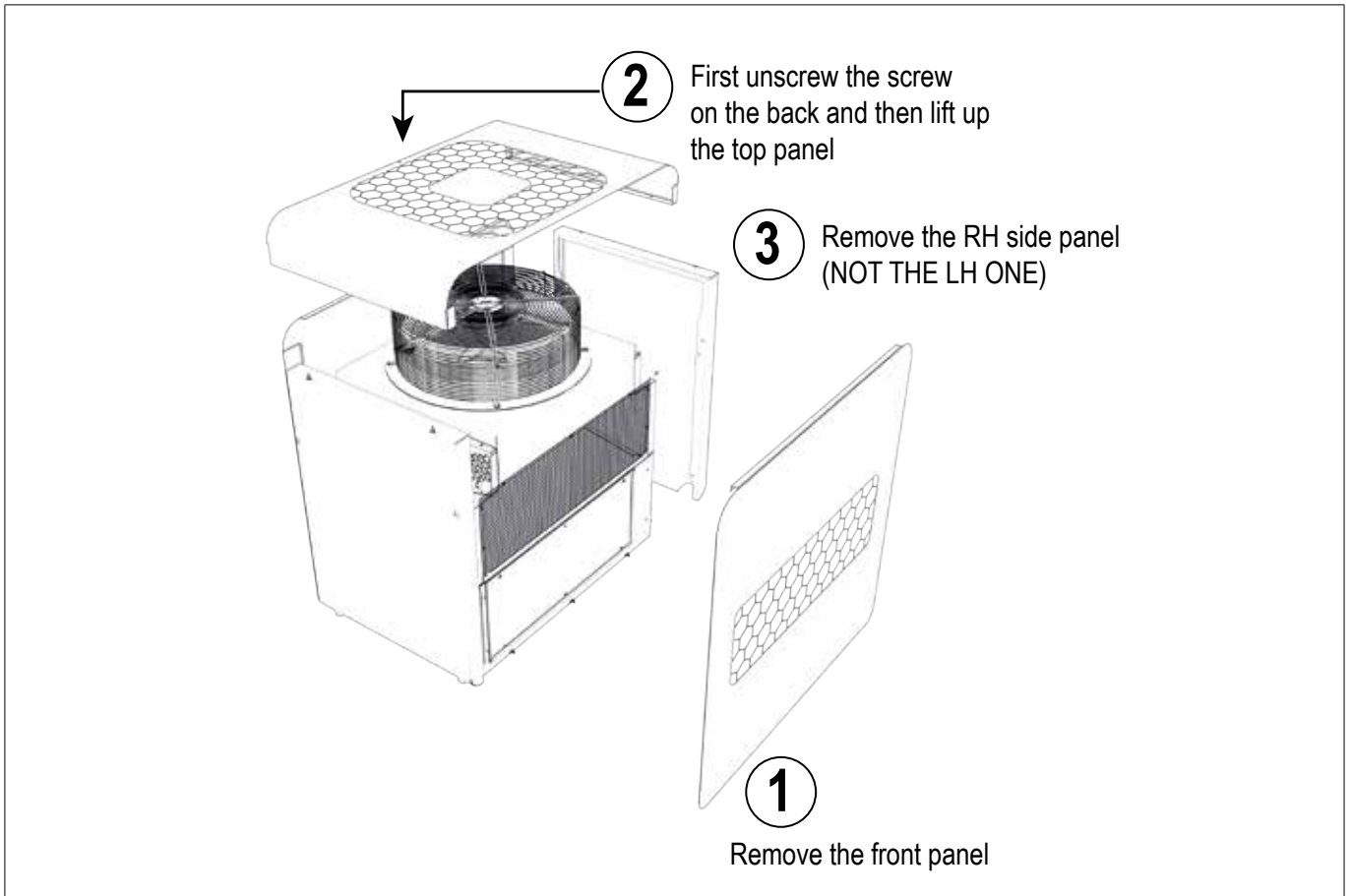

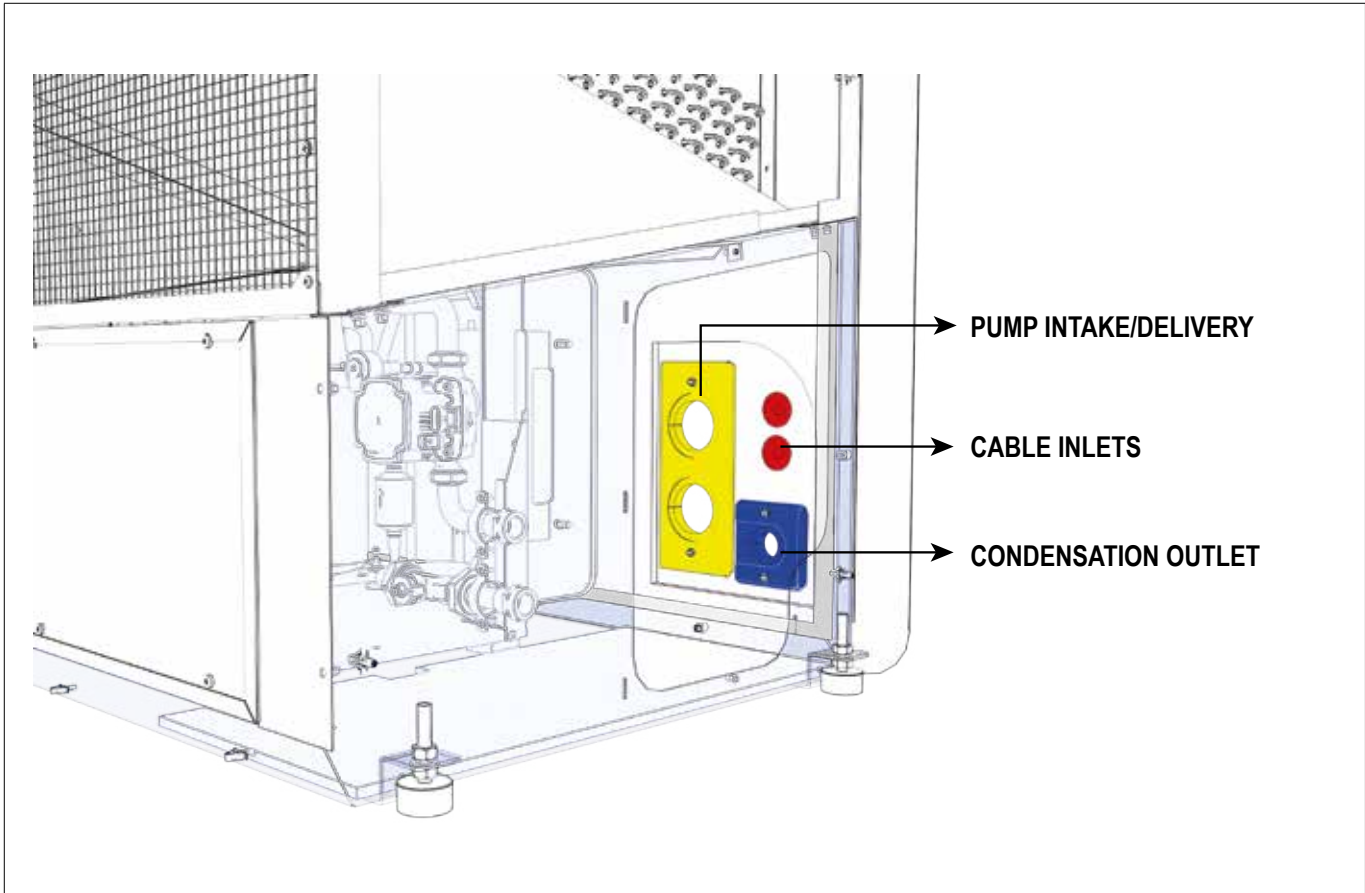

⚠ CAUTION

BEFORE LOCATING THE HEAT PUMP AGAINST THE WALL, ARRANGE THE SERVICE OUTLETS ON THE BACK PANEL



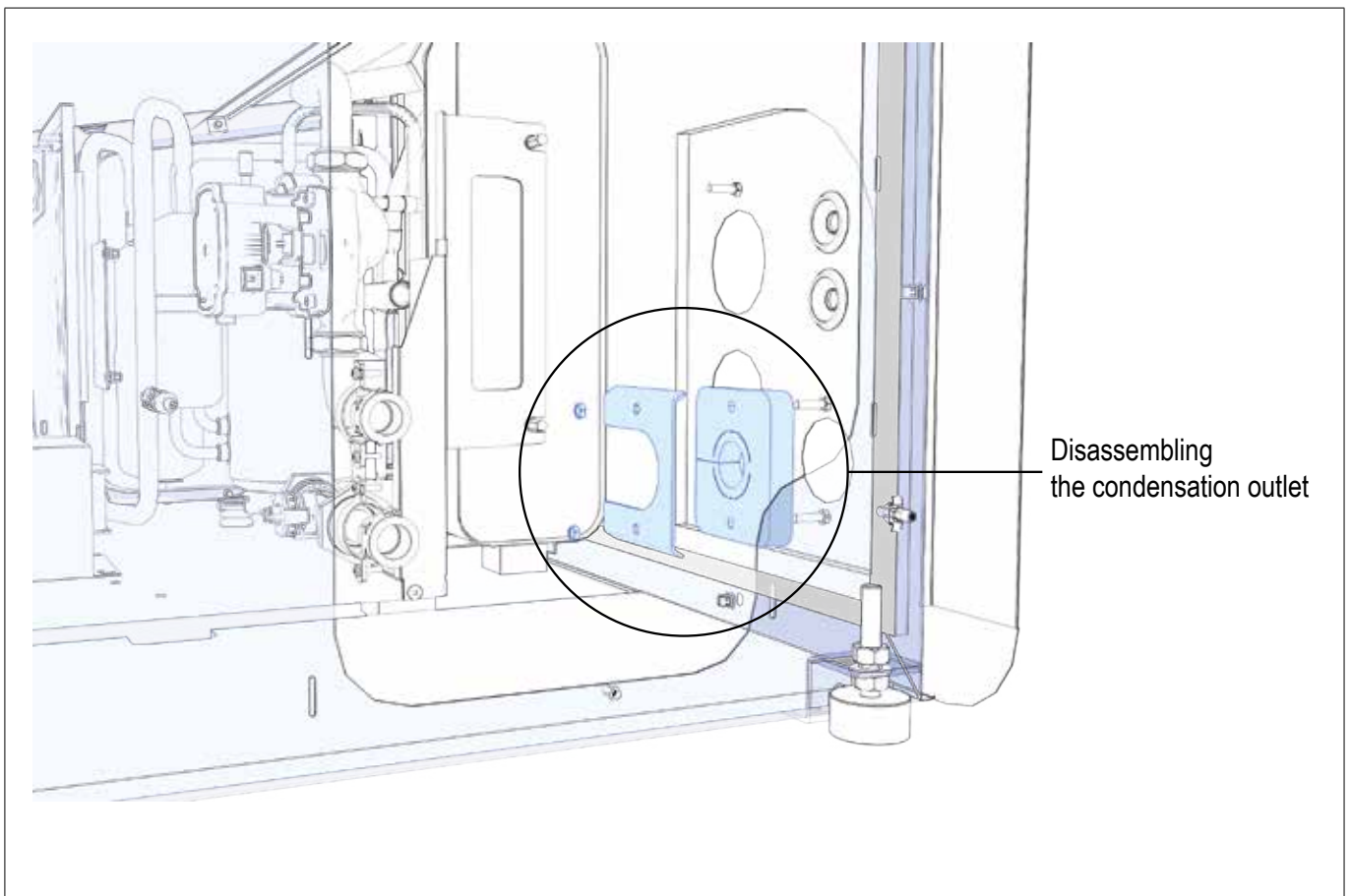
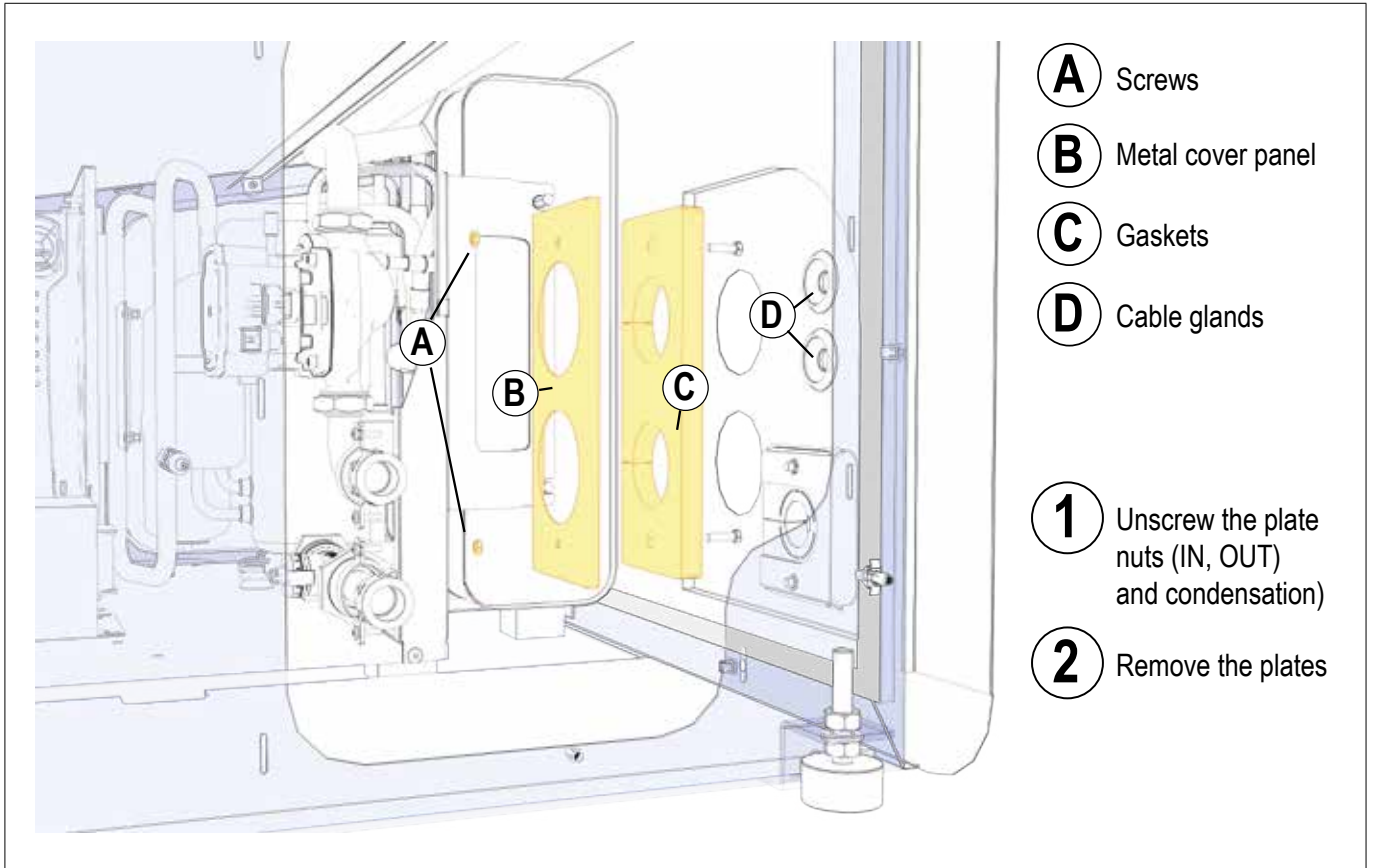

Locate the heat pump against the wall, making sure to route the service hoses as shown in the following figure.

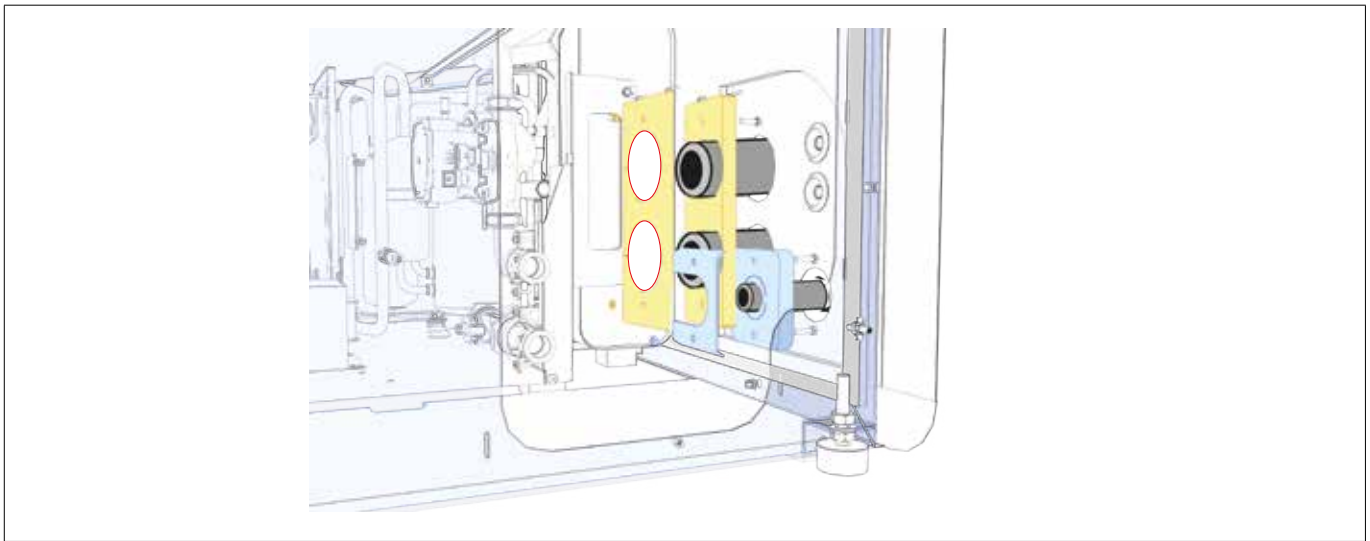
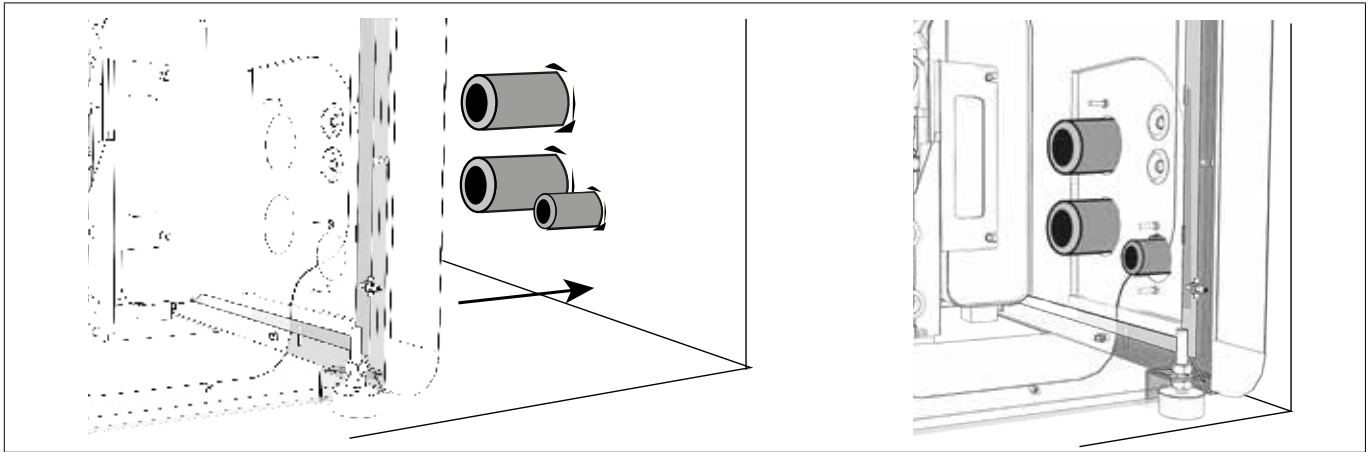

⚠ CAUTION



CAUTION: ONCE THE HOSES RUNNING FROM THE WALL INTO THE MACHINE ARE IN POSITION, FIT THE GASKET AND PLATE (IN THAT ORDER) BEFORE MAKING ANY OTHER CONNECTIONS. THEN SECURE THEM BY TIGHTENING DOWN THE NUTS TO COMPRESS THE GASKET AROUND THE HOSES.

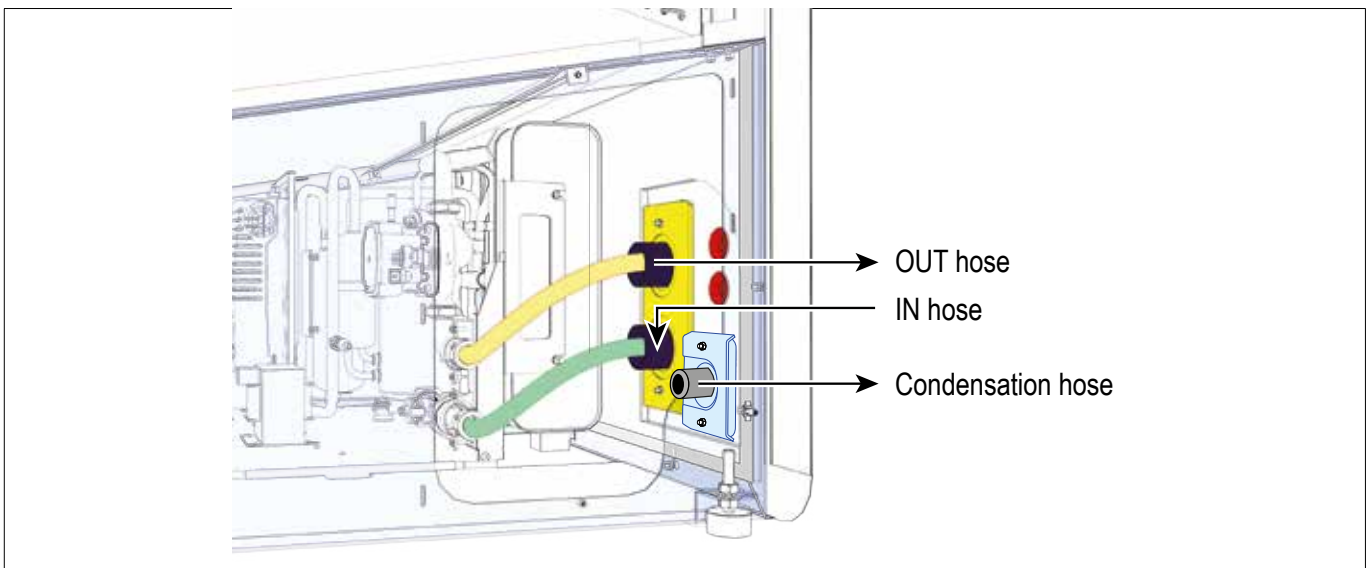



⚠ WARNING

COMPLETE THE WATER CIRCUIT HOOKUP WITH TWO HOSES

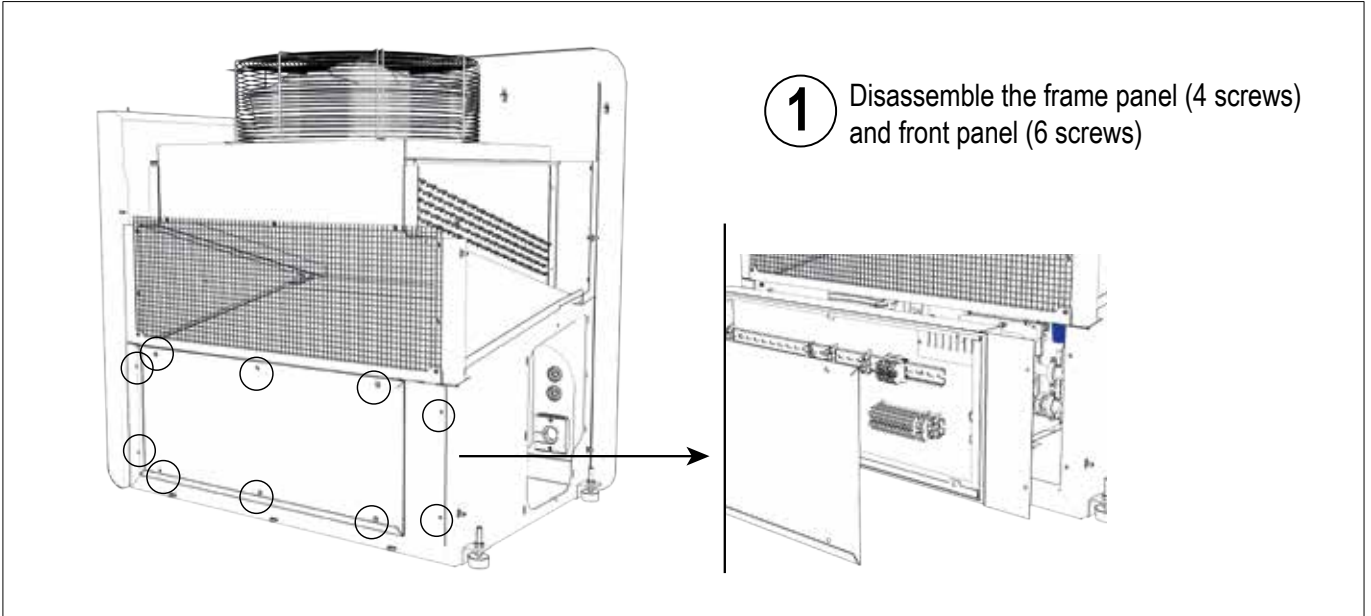

1 Disassemble the frame panel (4 screws) and front panel (6 screws)

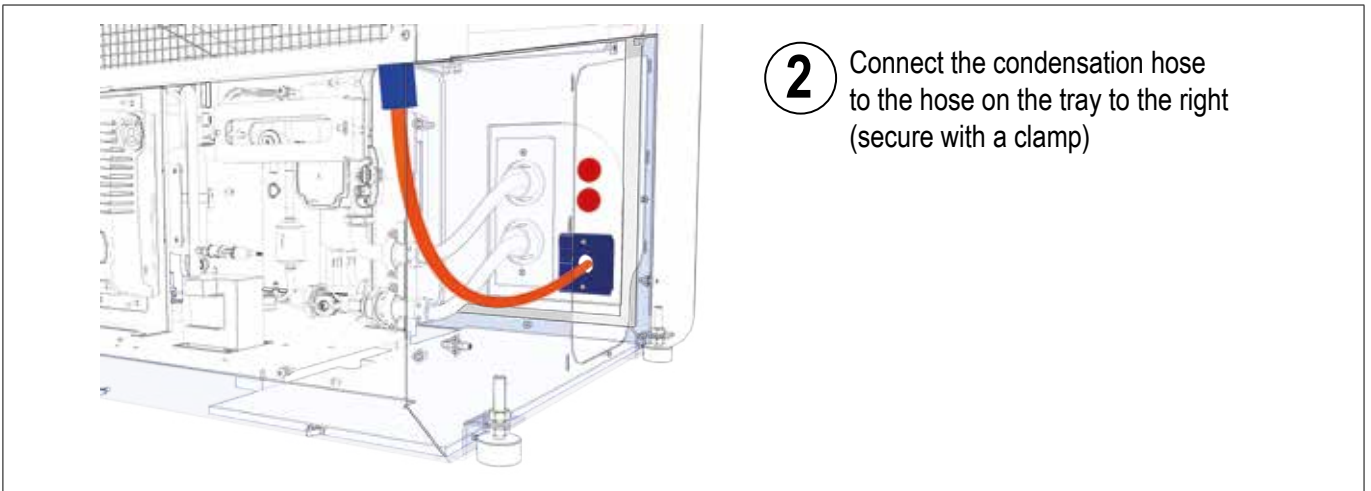

2 Connect the condensation hose to the hose on the tray to the right (secure with a clamp)

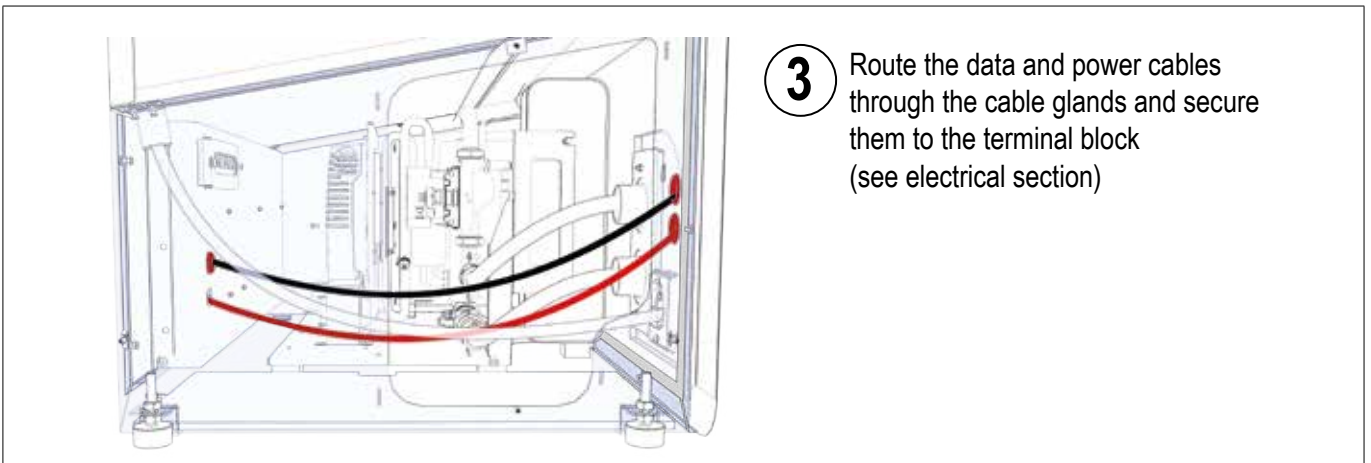

3 Route the data and power cables through the cable glands and secure them to the terminal block (see electrical section)

Reassemble everything (in reverse order).

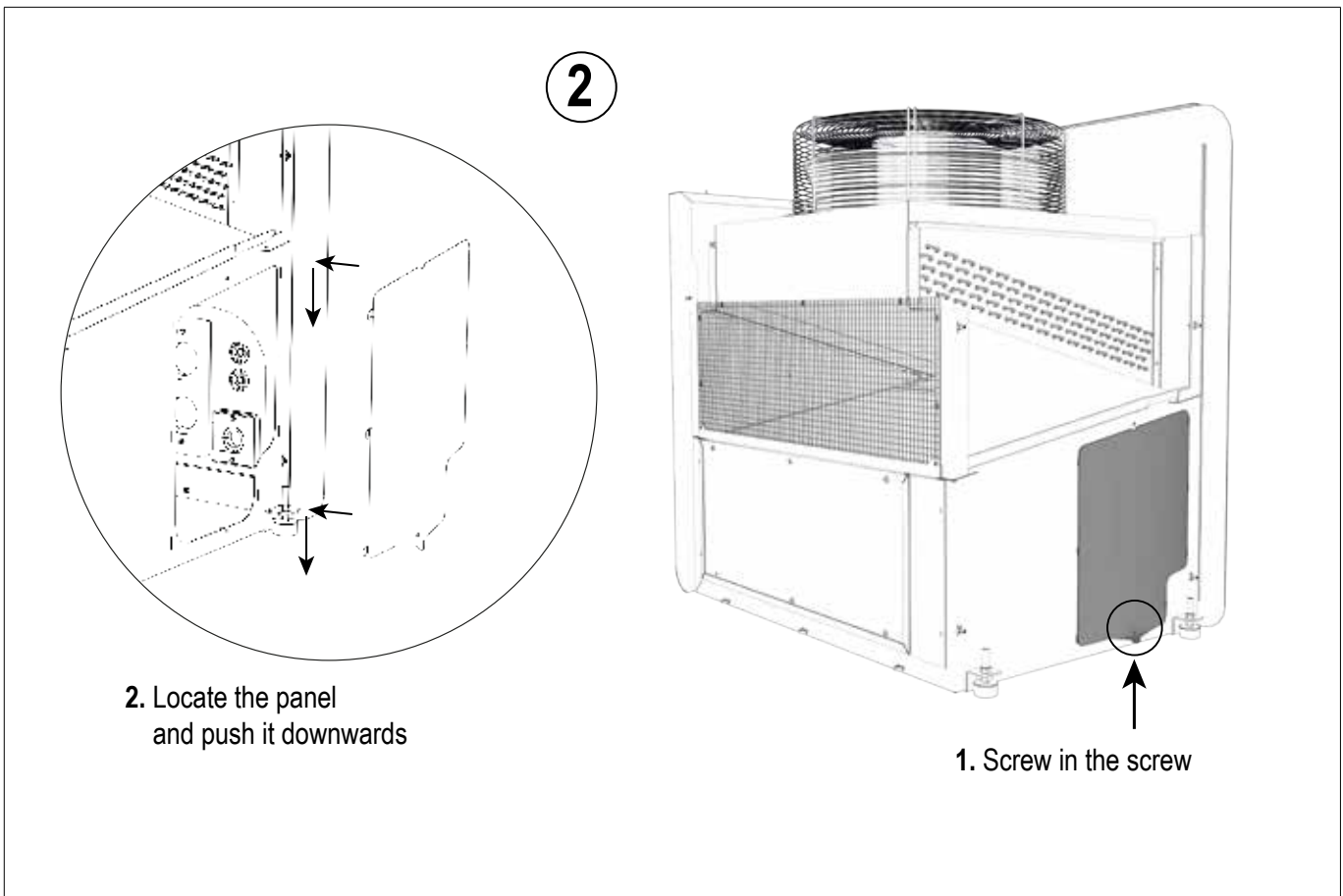
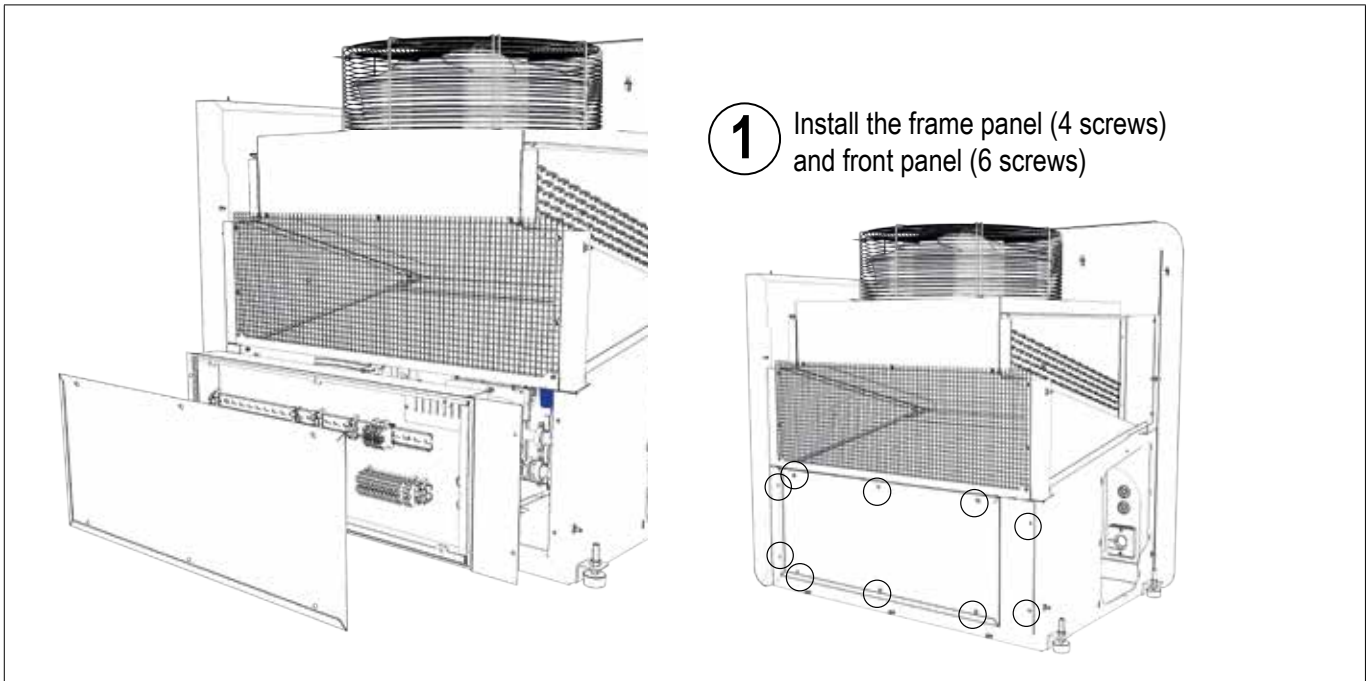

REMOVE THE EXTERNAL SECTION IN THE FOLLOWING ORDER.

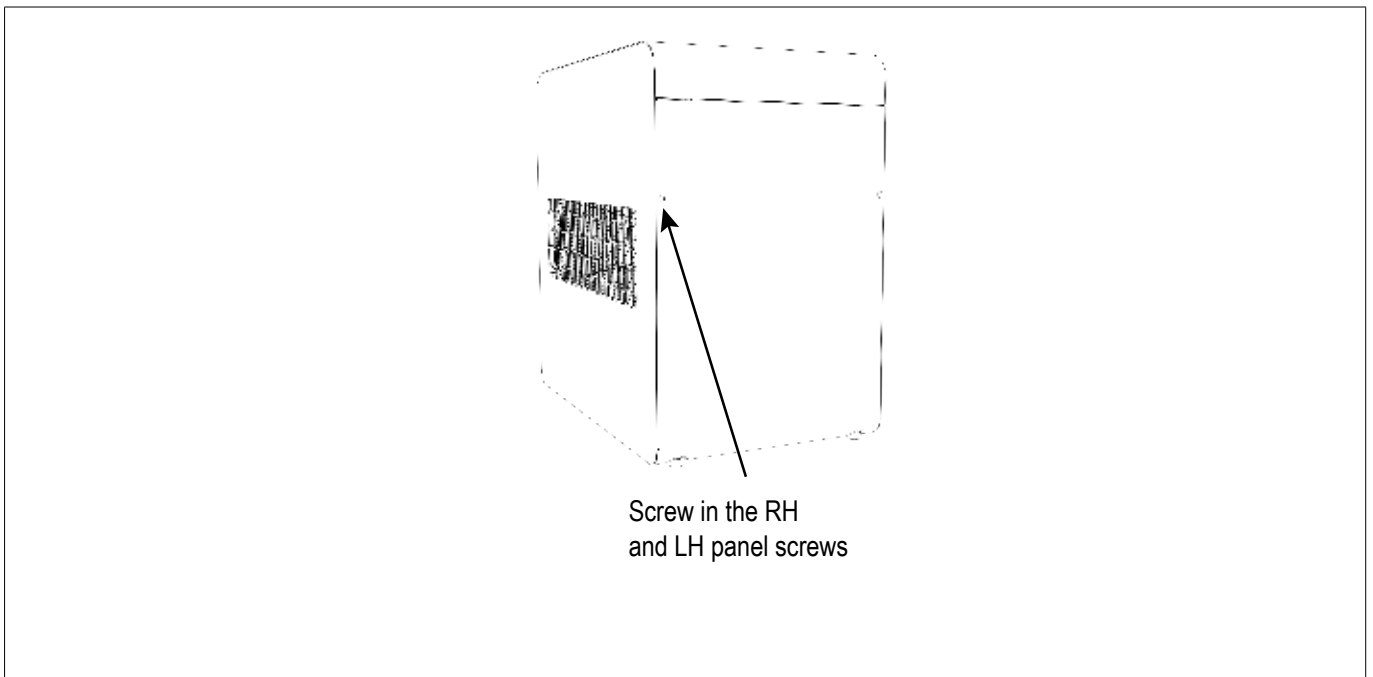
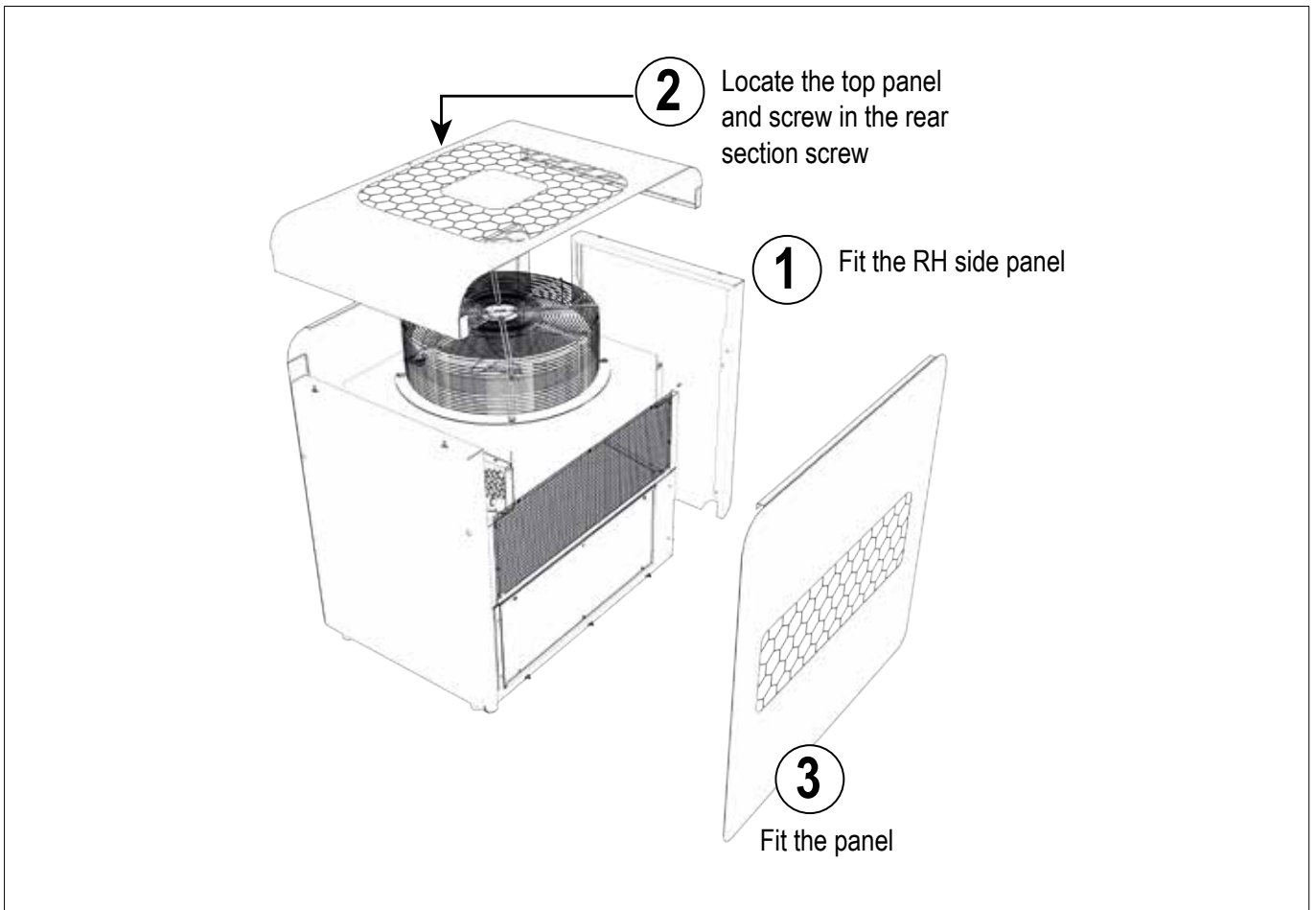

If the rh side is not easily accessible, the hookup can be done from the front.

Remove the lateral screws on the two panels and then remove only the front panel

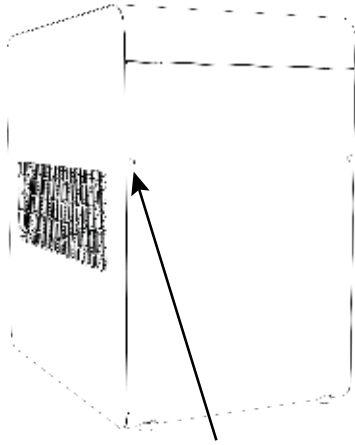

Undo the lateral screws on the RH and LH panels

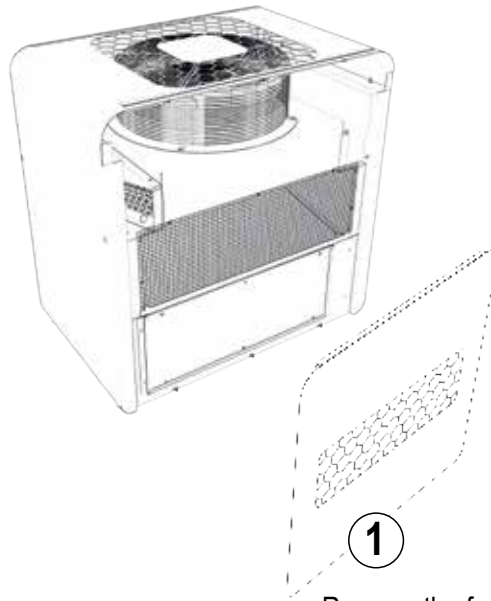

1 Remove the front panel

The disassembly procedure is as follows:

- Disassemble the electrical panel
- Disassemble the tray
- Disassemble the grille

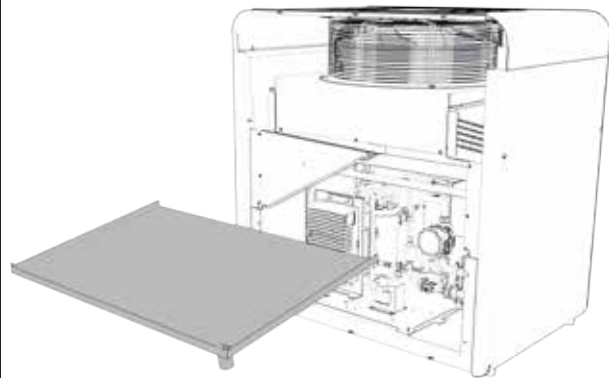
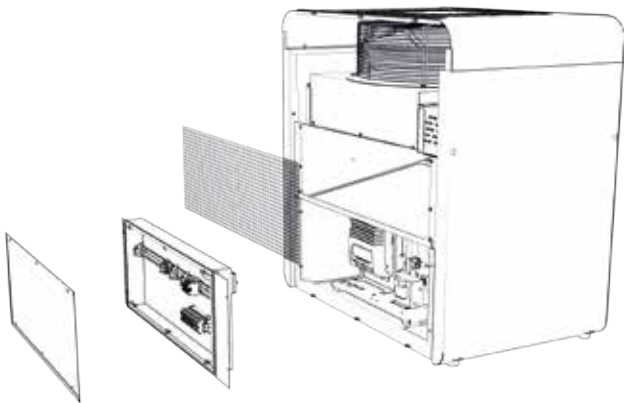

⚠ WARNING



THE HOOKUP PROCEDURE IS SIMILAR TO BEFORE. LOCATE THE HEAT PUMP AGAINST THE WALL AND HOOK UP THE SERVICES. ONCE EVERYTHING IS HOOKED UP, RESTORE THE GRILLE, TRAY AND PANEL.

- 1) Insert the power supply cable at the base of the machine or at the rear side, depending on the machine series, into the holes with cable glands (FIG. 41 - Ref. D)
- 2) Connect the earth wire on the PE terminal.
- 3) Connect wires L1, L2 and L3 on the power input terminal board.

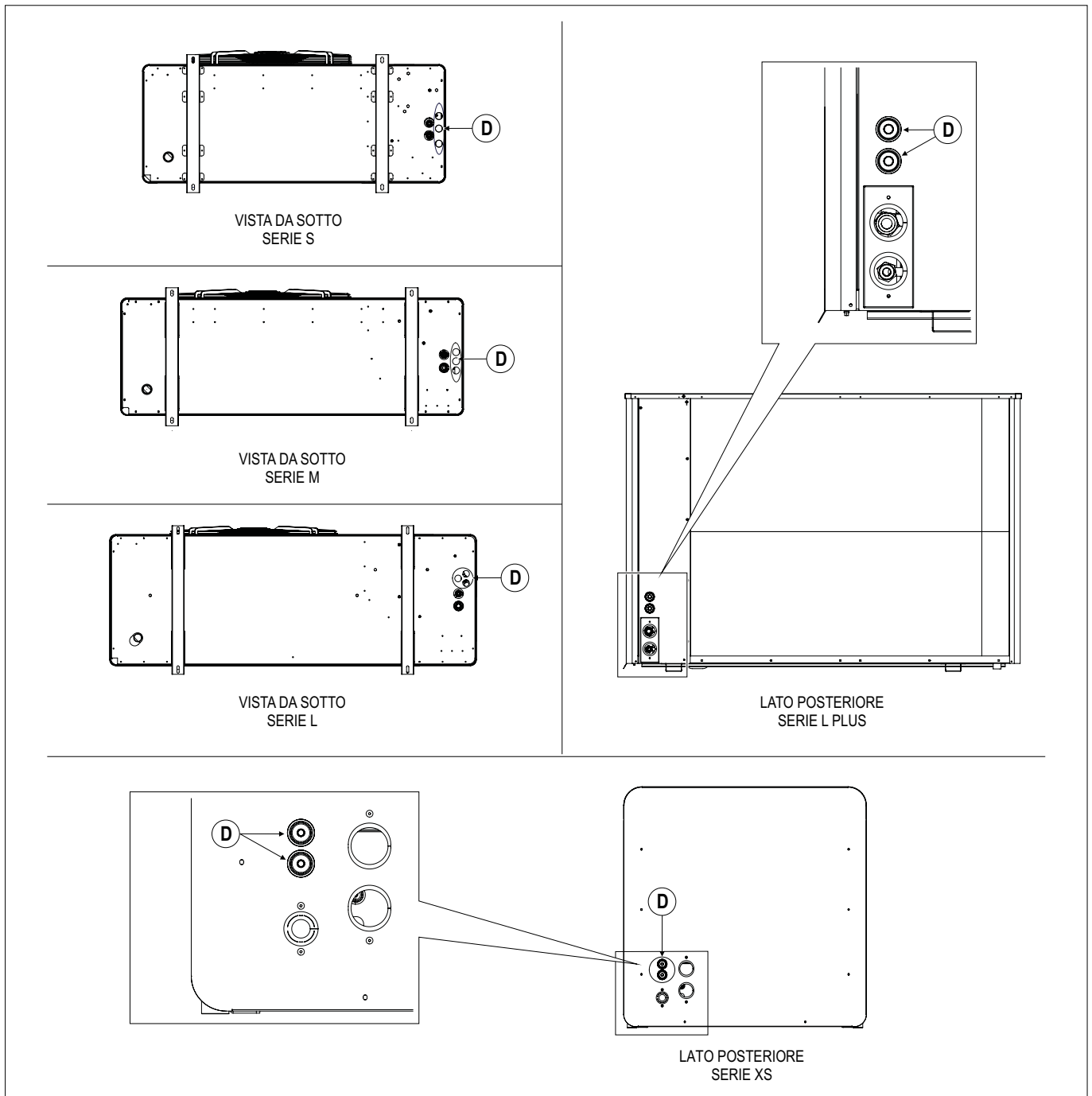

FIG. 47 (Connection to the electrical energy source)

13.9.10 INDICATIVE SECTION FOR CABLES AND INTERNAL PROTECTIONS



INFORMATION

THE SECTION OF THE POWER CABLES IS TO BE CONSIDERED INDICATIVE AND RELEVANT FOR THE LAST LENGTH OF THE LINE TO THE MACHINE, WHICH MUST BE AS SHORT AS POSSIBLE. THE EXTERNAL PROTECTIONS, INSTALLATION AND CABLE SECTION OF THE AFOREMENTIONED POWER SUPPLY LINE MUST BE SIZED AND CARRIED OUT BY AUTHORISED PERSONNEL IN ACCORDANCE WITH THE TECHNICAL STANDARDS OF THE RELEVANT NATIONAL AUTHORITIES.

Series	Mod.	Electrical supply	Electrical input current [kW]	INVERTER (A)	Circuit breaker (A)	Differential switch (mA)	Section of cables in mm ² (up to a length of 5 m)			
XS	XS-7,5	230 V (1 ph) 400 V (3 ph)	1,81	11 (1ph) 18 (1ph) 18 (3ph)	C10 (1ph); C6 (3ph)	30	3x2.5 (1ph) 3x4 (1ph) 5x2.5 (3ph)			
	XS-9		2,48		C13 (1ph); C6 (3 ph)					
	X-7,5		1,81		C10 (1ph); C6 (3ph)					
	X-9		2,48		C13 (1ph); C6 (3 ph)					
HRP	HRP-10		3,24	18	C16 (1ph); C6 (3ph)		30			
	HRP-12		4,01		C20 (1ph); C10 (3ph)					
	HRP-14		5,02		C25 (1ph); C10 (3ph)					
	HRP-16		5,31		C32 (1ph); C10 (3ph)					
SP-T	SP-8T	2,03	18		C10 (1ph); C6 (3ph)	30		3x4 (1ph) 5x2.5 (3ph)		
	SP-10T	2,69			C13 (1ph); C6 (3 ph)					
	SP-12T	3,32			C20 (1ph); C6 (3ph)					
SP	SP-8	2,15			18			C13 (1ph); C6 (3 ph)	30	3x4 (1ph) 5x2.5 (3ph)
	SP-10	2,88		C16 (1ph); C6 (3ph)						
	SP-12	5,07		C25 (1ph); C10 (3ph)						
MP	MP-14	4,74		30			C25 (1ph); C10 (3ph)	30		3x4 (1ph) 5x4 (3ph)
	MP-16	5,46					C32 (1ph); C10 (3ph)			
	MP-18	6,31	C13 (3ph)			5x4				
	MP-20	6,87								
LP	LP-22	7,48	30				30			5x6
	LP-26	9,49	38		C16 (3ph)	5x10				
	LP-28	10,47			C20 (3ph)					
	LP-32	12,56			C25 (3ph)					
	LP-35	14,18								
LP Plus	LP Plus-35	11,90		C20 (3ph)						
	LP Plus-40	14,07	C25 (3ph)							
LR	LR-35	10,84	38	C20 (3ph)	30	5x10				
	LR-35 Cold	12,47								
LR Plus	LR Plus-45	19,26	45	C32 (3ph)	30	5x16				

TAB. 28 (Indicative section for cables and internal protections)

13.10 PROBES AND REMOTE PANEL

The temperature probes **B2** (heating / cooling) and **B3** (domestic hot water) must be connected with a **1.5 mm²** shielded multipolar cable following the shortest path and away from power cables.

Particular attention should be paid to the joints as any parasitic resistors affect the readings from the control board. The remote panel cable (6-wire Ethernet cable) can be laid together with the probe cable with the same precautions.



INFORMATION

WE RECOMMEND USING A FERRITE TOROID TO PROTECT THE REMOTE PANEL FROM ANY EXTERNAL DISTURBANCES.

13.11 TERMINAL WIRING

13.11.1 OUTDOOR UNIT μ PC WIRING

The available connections are listed below.

⚠ WARNING

PROBES **B2** AND **B3** MUST BE CONNECTED TO THE PRE-WIRED CABLE SUPPLIED WITH THE MACHINE.

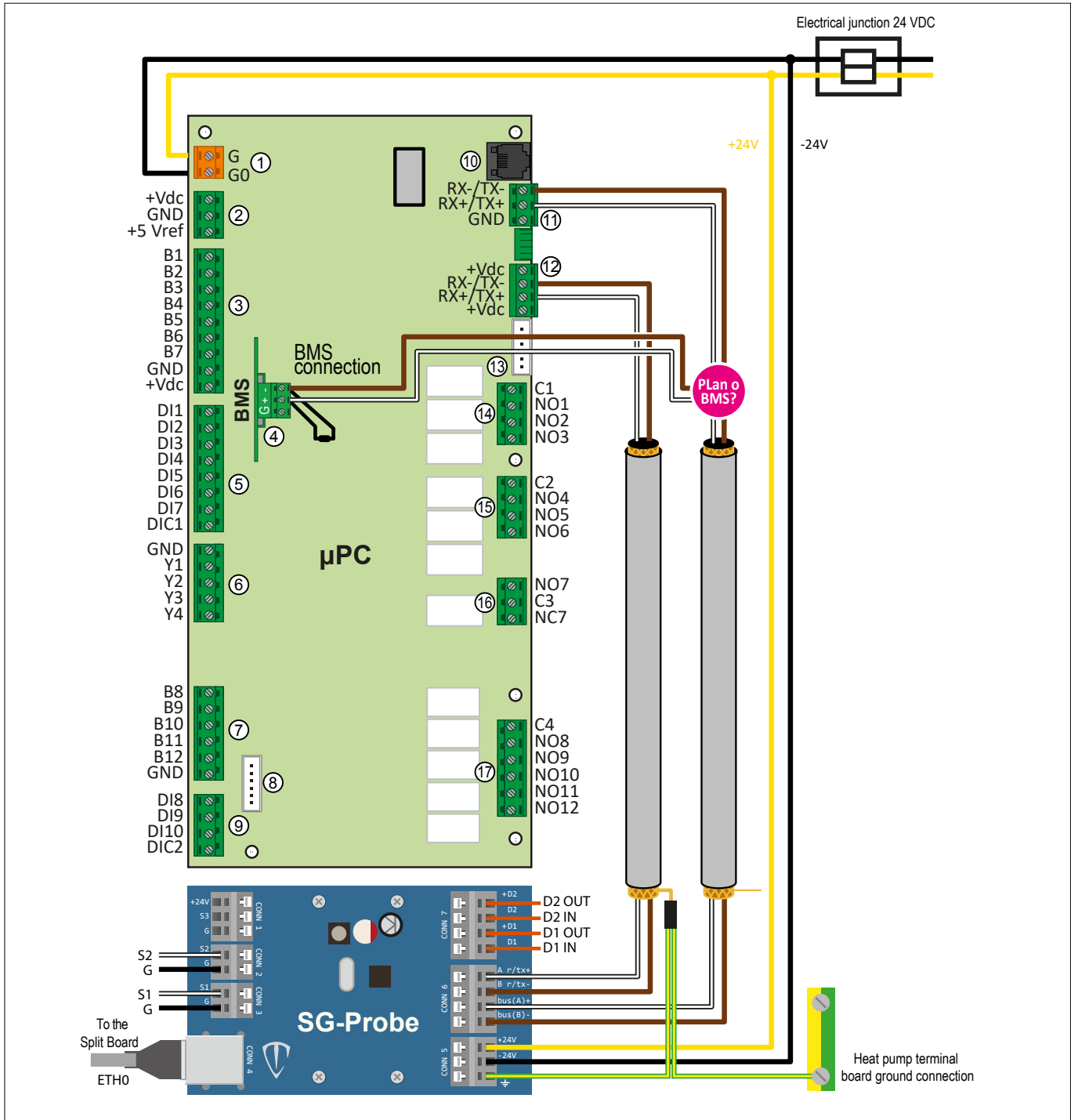

FIG. 48 (Outdoor unit μ PC wiring)

13.11.2 DIGITAL OUTPUTS

Ref.	Function	Ref.	Function
NO1	Integration	NO7	General alarm
NO2	Forcing thermostatic heads	NO8	Req. Integ. DHW
NO3	Air-to-air or air-to-water indicator	NO9	3-way valve
NO4	Circulator	NO10	4-way valve
NO5	Condensate heater	NO11	Oil heating system
NO6	Req. Integ. Plant	NO12	Desuperheater

TAB. 29 (Electronic board - Digital outputs)

13.11.3 DIGITAL INPUTS

Ref.	Function	Ref.	Function
DI1	Summer/Winter switching	DI6	Solar power integration
DI2	-	DI7	Auxiliary system heater ALR
DI3	-	DI8	Remote On-Off
DI4	No Power Supply	DI9	Modbus comm. switch
DI5	Disable system	DI10	Flow Switch / Plant Aware

TAB. 30 (Electronic board - Digital inputs)

13.11.4 ANALOG OUTPUTS

Ref.	Function	Ref.	Function
Y1	/	Y3	PWM circulator
Y2	KITA Air indoor unit fan	Y4	KITA Air outdoor unit fan

TAB. 31 (Electronic board - Analog outputs)

13.11.5 ANALOG INPUTS

Ref.	Function	Ref.	Function
B1	Subcooling	B7	Delivery temperature
B2	Radiant circuit temperature	B8	Outdoor temperature
B3	DHW circuit temperature	B9	Discharge temperature
B4	Return temperature	B10	Compressor intake temperature
B5	Flowmeter	B11	High pressure transducer
B6	Compressor head temperature	B12	Low pressure transducer

TAB. 32 (Electronic board - Analog inputs)

13.11.6 ELECTRONIC BOARD μ PC

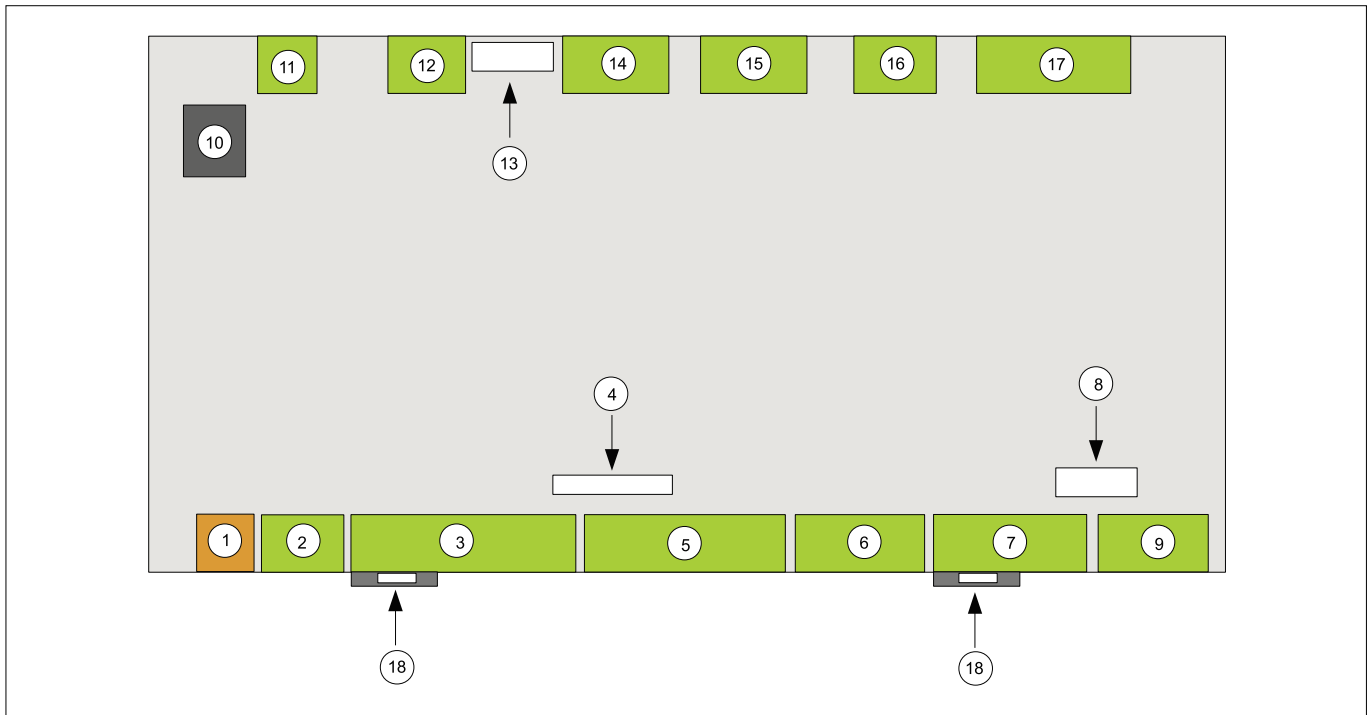

FIG. 49 (Electronic board)

Ref.	Function	Ref.	Function
1	24 VDC power supply	10	P-LAN 1 Operator panel
2	Sensor power supply	11	P-LAN 2
3	Analog inputs B1 to B7	12	FieldBus port
4	BMS port	13	Expansion valve
5	Digital inputs DI1 to DI7	14	Block C1 outputs NO1 to NO3
6	Analog outputs Y1 to Y4	15	Block C2 outputs from NO4 to NO6
7	Analog inputs B8 to B12	16	Block C3 outputs No7 to Nc7
8	Injection valve	17	Block C4 outputs NO8 to NO12
9	Digital inputs DI8 to DI12	18	Din 35 bar hooks

TAB. 33 (Electronic board)

13.11.7 SG-PROBE ELECTRONIC BOARD

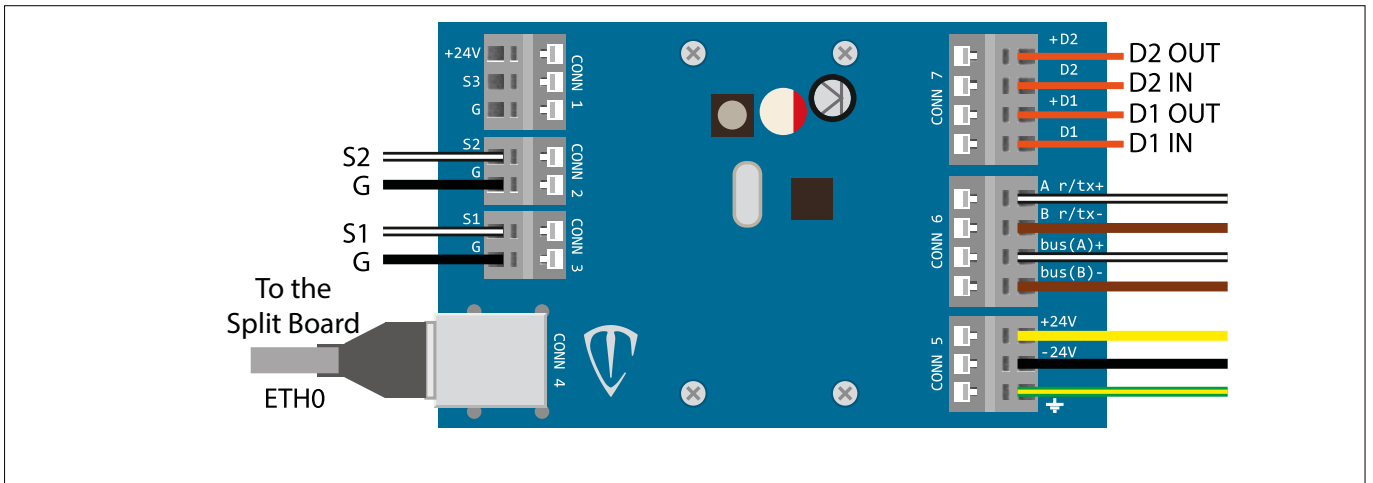

FIG. 50 (SG-Probe electronic board)

Ref.	Function	Ref.	Function
CONN 1	Optional probe input	CONN 5	24VDC power supply input
CONN 2	Air exchanger probe input	CONN 6	Communication Bus input
CONN 3	Plate heat exchanger probe input	CONN 7	SG-Ready contact inlet
CONN 4	RJ45 connector for T-Split Board		

TAB. 34 (SG-Probe electronic board)

SG-Probe electronic board IN/OUT

Ref.	Function	Ref.	Function
D1 OUT (+D1)	SG1 clean contact power supply	S1	Air exchanger outlet temperature / refrigerant gas
D1 IN	SG1 clean contact return	S2	Plate heat exchanger inlet temperature refrigerant
D2 OUT (+D2)	SG2 clean contact power supply	G	Probes S1 and S2 ground
D2 IN	SG2 clean contact return		

TAB. 35 (SG-Probe electronic board IN/OUT)

13.11.8 SECONDARY ELECTRICAL PANEL TERMINAL BOARD - K-TOUCH PANEL CONNECTION

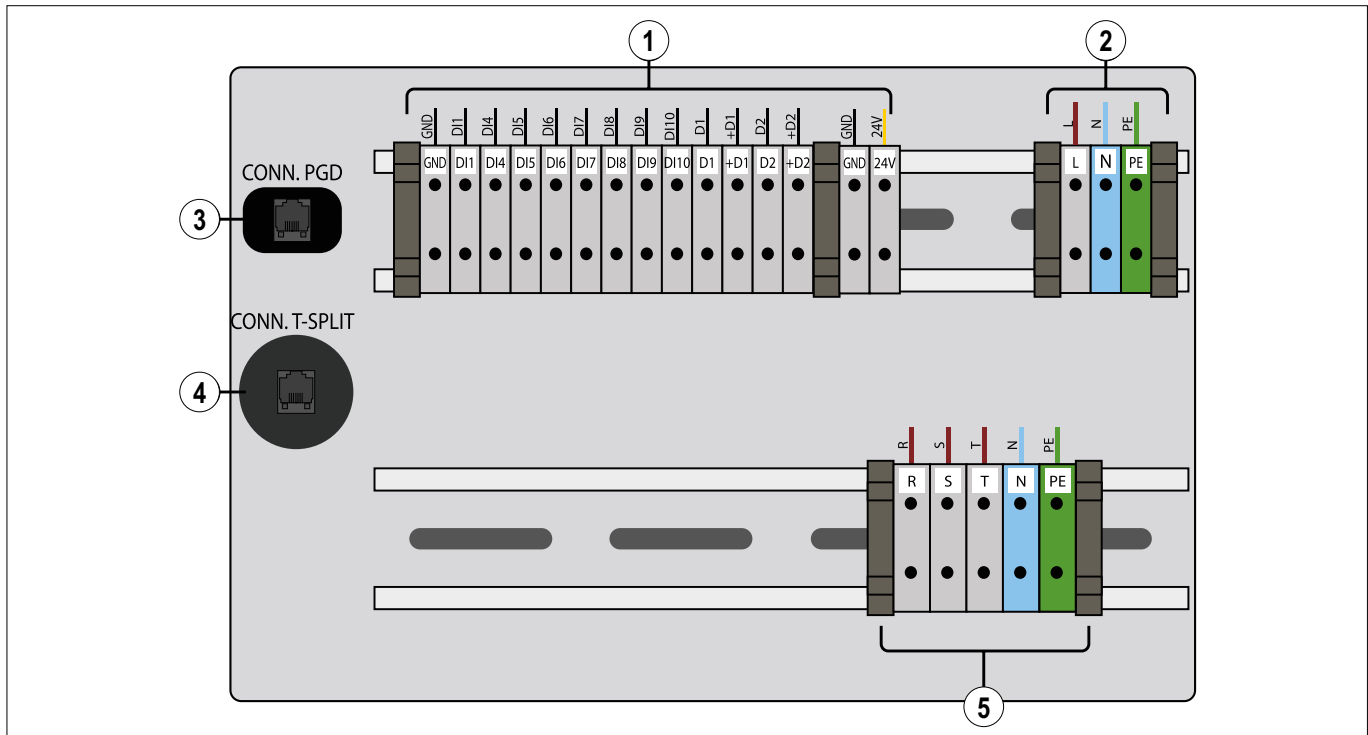

FIG. 51 (Secondary electrical panel terminal board)

Ref.	Function	Ref.	Function
1	Digital and 24VDC contact terminal board	D15	Disable system
2	230 VAC power supply for T-Split board	D16	Photovoltaic inverter overproduction contact
3	Connector for PGD	D17	System auxiliary air heater
4	RJ45 connector for T-Split board	D18	Remote On-Off
5	Main Power Supply PDC 3PH or 1PH	D19	Modbus comm. switch
24 V	24 V power supply	D10	Flow Switch / Plantaware
D1	Ritorno contatto pulito SG1	PE	Earthing
+D1	Alimentazione contatto pulito SG1	R	Phase 1
D2	Ritorno contatto pulito SG2	S	Phase 2
+D2	Alimentazione contatto pulito SG2	T	Phase 3
GND	Earthing system	N	Neutral
D11	Summer/Winter switching	L	Fuse-protected T-Split board power supply line
D14	No power supply	N	T-Split power supply neutral.

TAB. 36 (Secondary electrical panel terminal board - K-Touch panel connection)

13.11.9 TERMINAL BLOCK OF SECONDARY ELECTRICAL CABINET FOR DUAL-SUPPLY HEAT PUMP

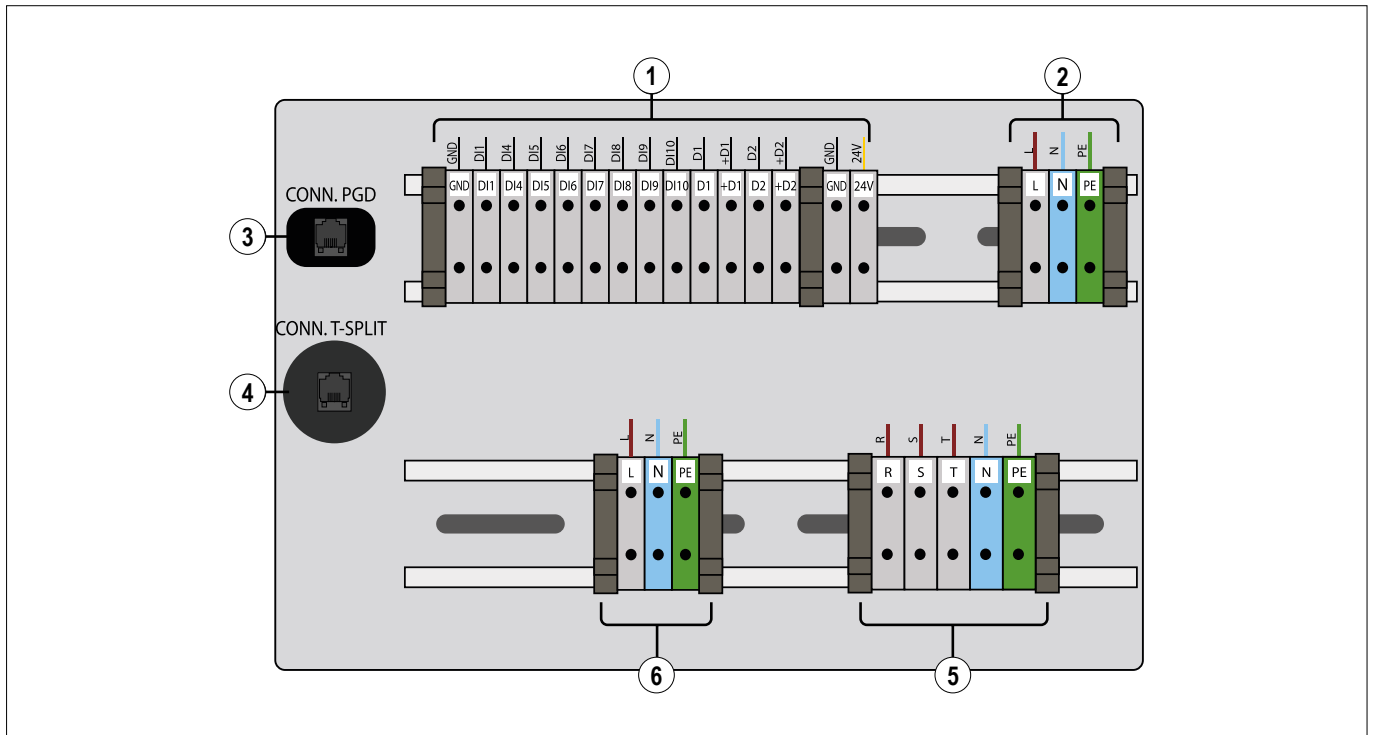

FIG. 52 (Secondary electrical cabinet terminal board for Dual-Supply heat pump)

Ref.	Function	Ref.	Function
1	Digital and 24VDC contact terminal board	DI5	Disable system
2	230 VAC power supply for T-Split board	DI6	Photovoltaic inverter overproduction contact
3	Connector for PGD	DI7	System auxiliary air heater
4	RJ45 connector for T-Split board	DI8	Remote On-Off
5	Main Power Supply PDC 3PH or 1PH	DI9	Modbus comm. switch
6	Low-power 1PH supply for dual-supply units	D10	Flow Switch / Plantaware
24V	24 V power supply	PE	Earthing
D1	Ritorno contatto pulito SG1	R	Phase 1
+D1	Alimentazione contatto pulito SG1	S	Phase 2
D2	Ritorno contatto pulito SG2	T	Phase 3
+D2	Alimentazione contatto pulito SG2	N	Neutral
GND	Earthing system	L	Fuse-protected T-Split board power supply line
DI1	Summer/Winter switching	N	T-Split power supply neutral.
DI4	No power supply		

TAB. 37 (Terminal block of secondary electrical cabinet for dual-supply heat pump)

13.11.10 T-SPLIT MODULE

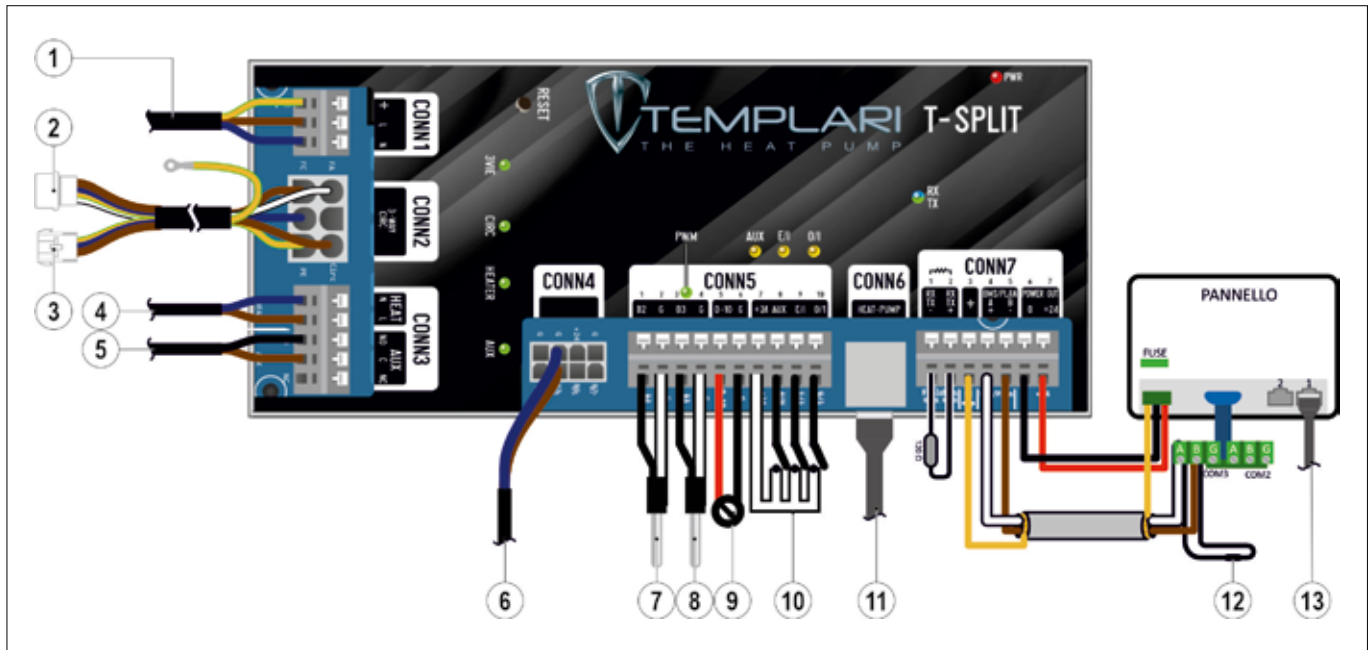

FIG. 53 (T-SPLIT module)

Ref.	Function	Ref.	Function
1	T-Split 230 V AC power supply from PDC electrical panel	8	DHW probe
2	3-way valve connection.	9	Optional 0/10 V input
3	Circulator 230 V AC power supply	10	Programmable clean contact inputs
4	Remote switch 1 230 V AC power supply	11	RJ45 from PDC electrical panel
5	Clean exchange for remote switch 2 power supply	12	120 Ω terminal resistor
6	PWM circulator	13	Modem / Router
7	System probe		

TAB. 38 (T-Split module)

13.11.11 THREE-WAY VALVE CONNECTION

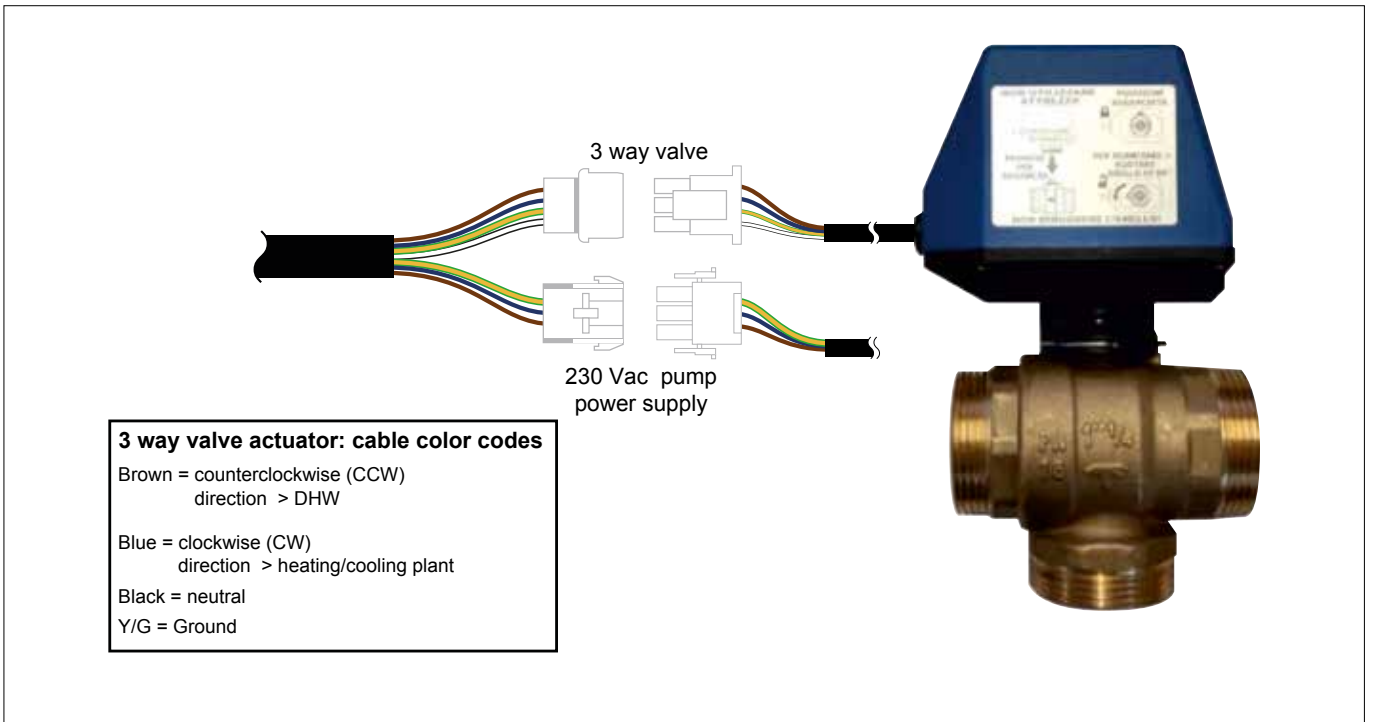

FIG. 54 (Three-way valve connection)

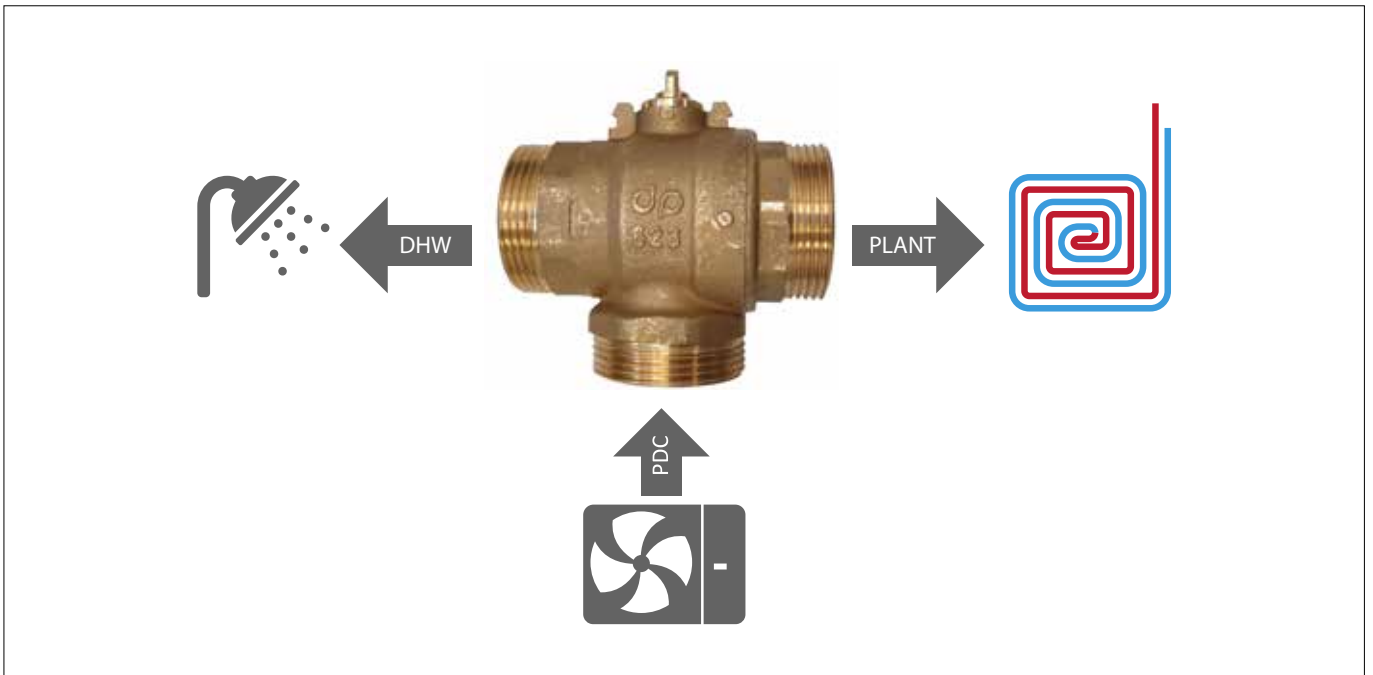

FIG. 55 (Three-way valve hydraulic connections)

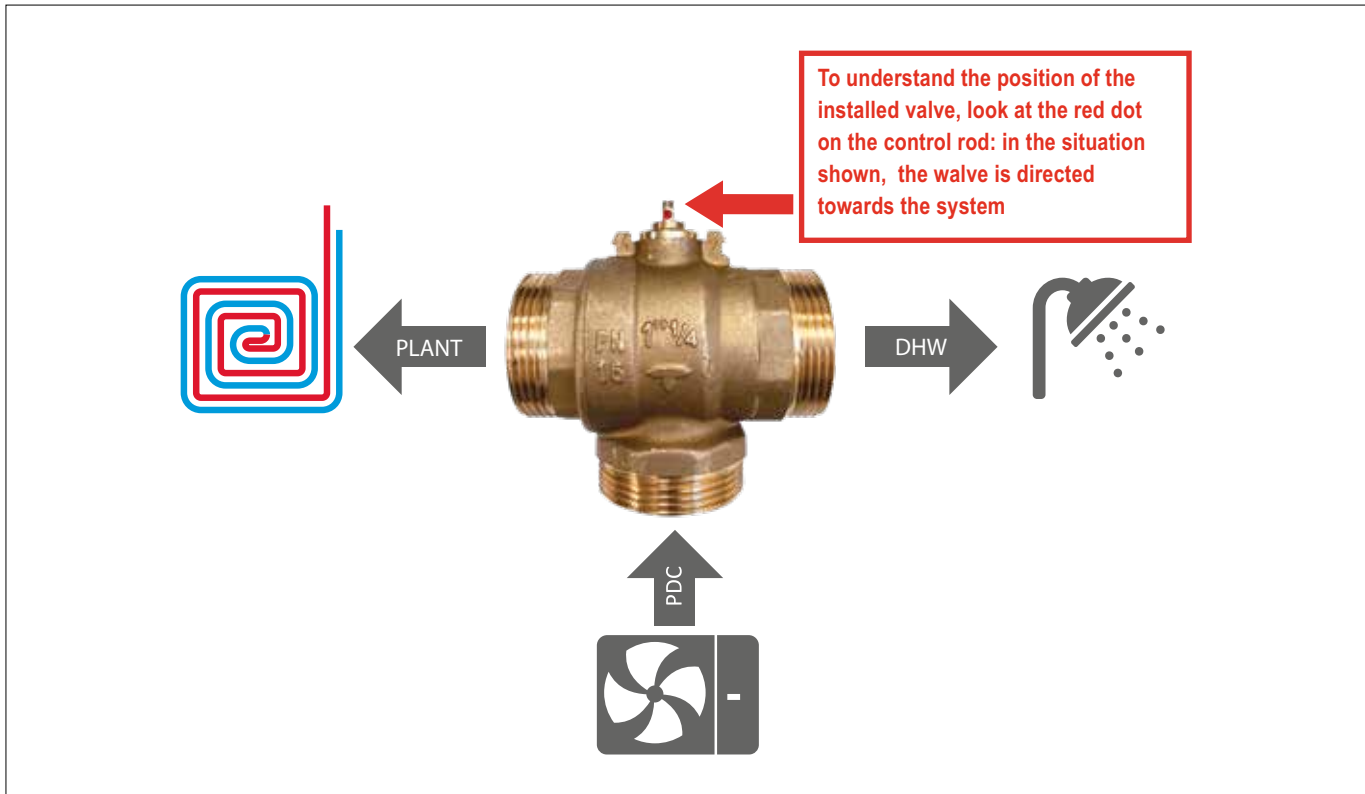

FIG. 56 (Three-way valve hydraulic connections)

13.11.12 PLANT AWARE FUNCTION

The Plant Aware (PA) function modifies the ignition hysteresis with respect to the temperature setpoint of the heat pump in response to opening or closing a clean contact on digital input 10.

If the clean contact is closed, the machine works to reach the setpoint with standard ignition hysteresis. If the clean contact is open, the heat pump is in “sleep” mode and will increase the hysteresis in order to avoid continuous topping up of the unused inertia tank.

PGD

The function can be enabled and disabled via the **PGD** panel from screen **Gfc 65**.

K-Touch

In this mode, there are no ROOM sensors or cMix cards.

The Plant Aware function of the K-Touch system overrides and replaces the heat pump system.

Therefore, if the panel has enabled the Plant Aware function, it will be impossible to disable it from **PGD**.

Clean contact 10 on the μ PC is used.

HCC

The Plant Aware function can be enabled using the HCC panel from the “Other” screen.

In this mode there is at least one ROOM sensor or one cMix card.

The Plant Aware function of the HCC system overrides and replaces the heat pump system.

If neither a ROOM sensor nor a cMix card is requested, the HCC system activates SLEEP mode, otherwise the heat pump will work as usual. Clean contact 10 on the μ PC is ignored.

Installer tasks

The clean contact must be closed when at least one apparatus or zone requires water from the inertia tank (logical OR of circulator controls).

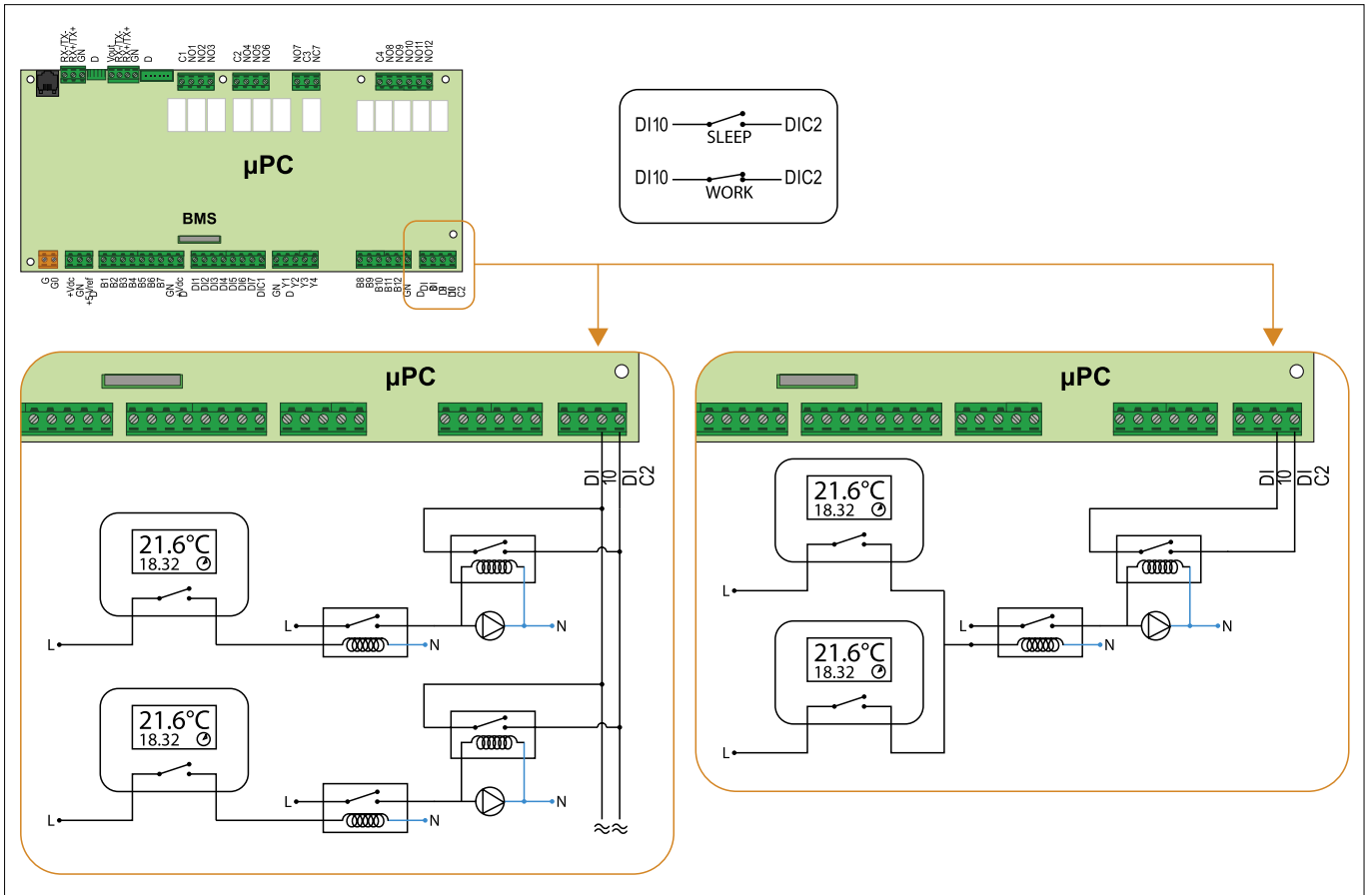

FIG. 57 (Plant Aware functions)

13.12 SG READY PROTOCOL

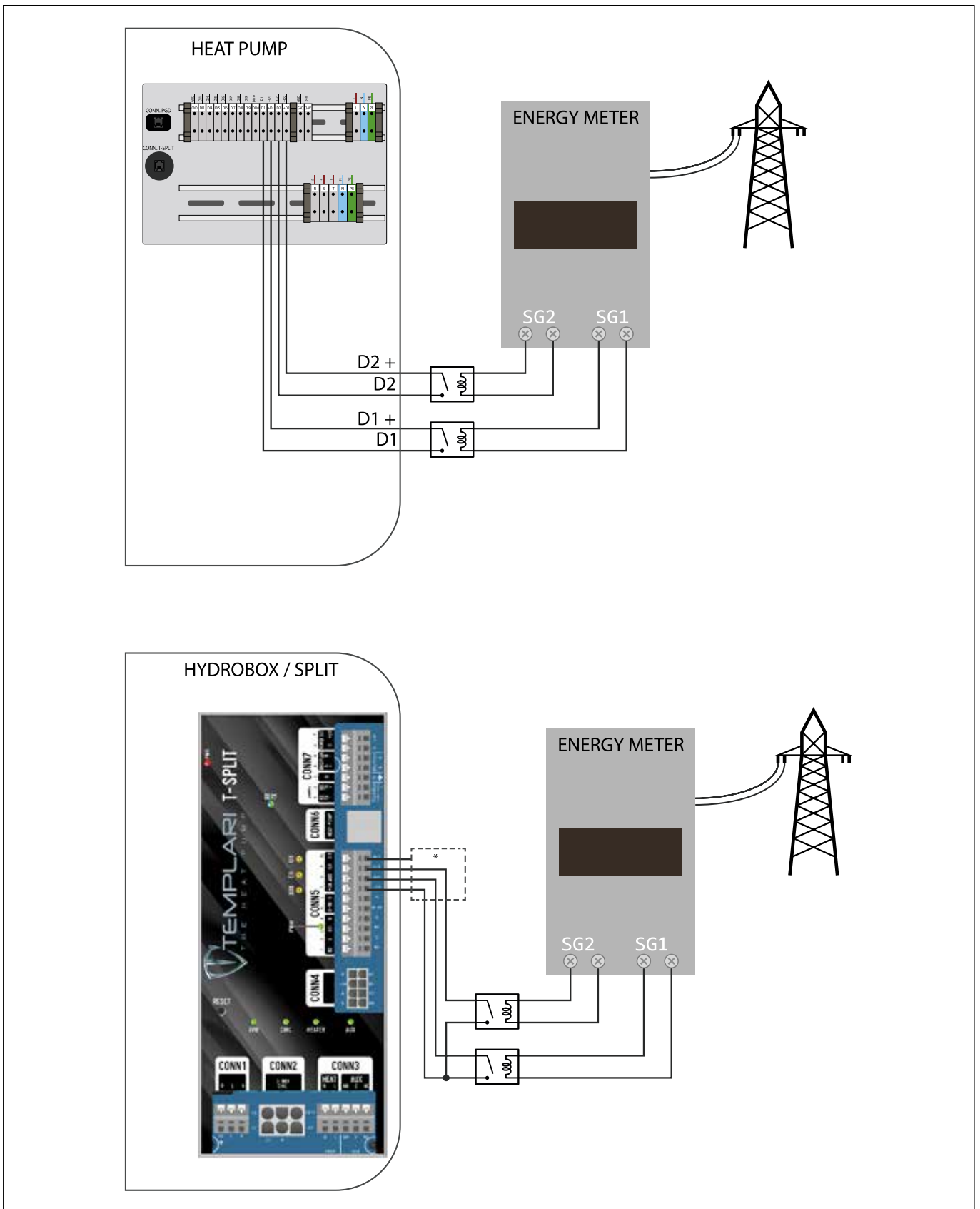

FIG. 59 (SG Ready Protocol)

13.13 SMART-GRID OPERATION

Through the SG protocol, the power grid operator issues commands to define the operating mode of the PDC. By reading the status of contacts SG1 and SG2, it can establish its operating mode. The following are the operating modes, based on the states of inputs D1 (SG1) and D2 (SG2).

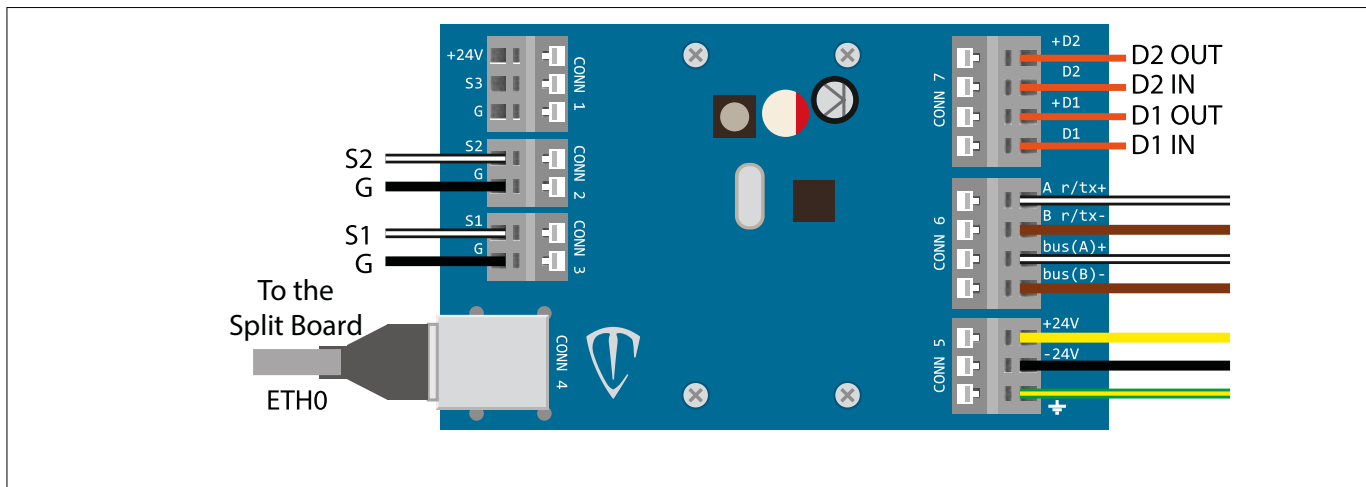

FIG. 60 (SG-Probe electronic board)

Mode	Description	D1 (SG1)	D2 (SG2)
1	Forced shutdown (max 2 h), which may vary based on commercial agreements with the power grid operator	1	0
2	Normal or standard operation. The heat pump works normally, according to its own settings. No external intervention by the power grid operator	0	0
3	Forced ignition up to programmed power (parameterizable). The power grid operator determines PDC ignition, setting a maximum absorption ceiling, which can be defined by the parameter MAX . Power (FIG. 54 - B12)	0	1
4a	Forced ignition up to maximum power without the use of electrical integrations	1	1
4b	Forced ignition up to maximum power and ignition of any electrical integration, typically the heating elements installed inside the puffers	1	1

TAB. 39 (Electronic board)

INFORMATION



MODE 4 (4a AND 4b) CAN BE DEFINED BASED ON THE SELECTION OF THE PARAMETER "EL. INTEGRATION" (FIG. 54 - B11), WHICH IF ACTIVE WILL RESULT IN SWITCHING ON THE DHW HEATING ELEMENT AND THE PLANT HEATING ELEMENT ONLY IF THE SYSTEM IS IN HEATING MODE

13.13.1 SWITCHBOARD XS

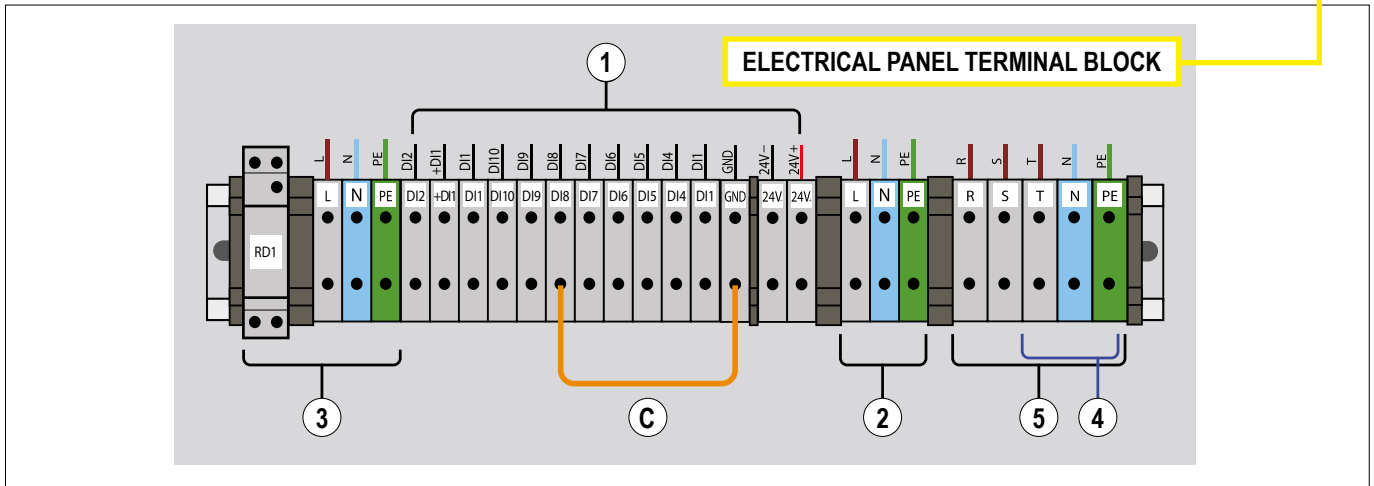
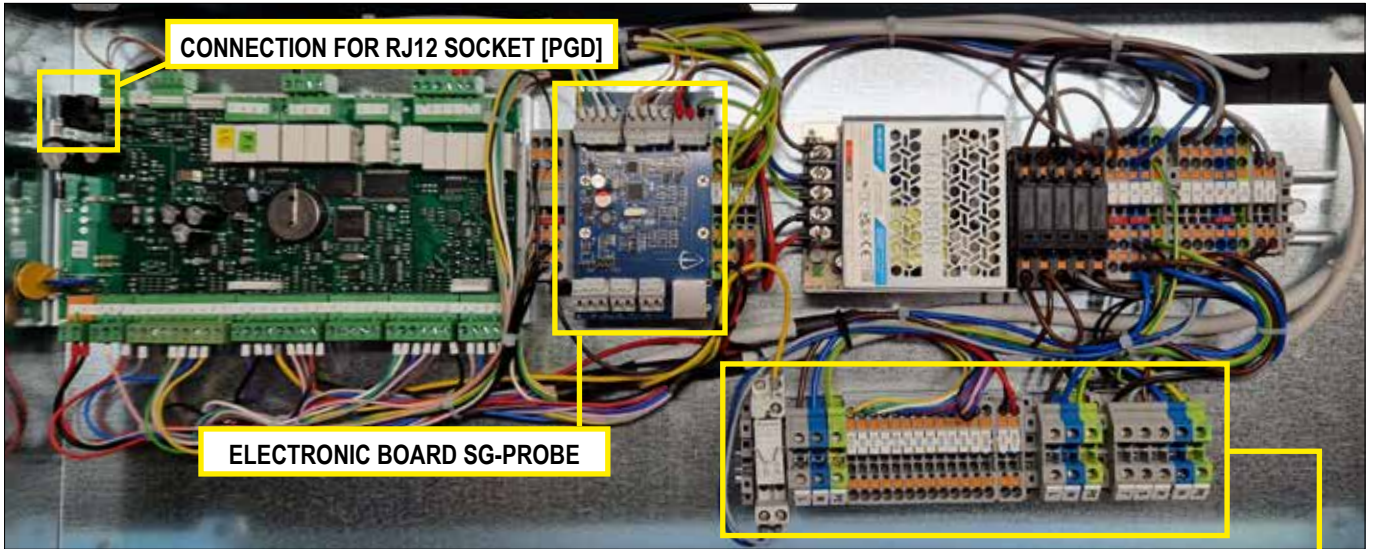

Ref.	Function	Ref.	Function
1	Digital and 24VDC Contact Terminal Block	DI5	Disable plant
2	230 VAC power supply for t-split board SEE CONNECTION (1) T-SPLIT MODULE	DI6	Photovoltaic inverter overproduction contact
3	Single-phase power supply (dual power supply only)	DI7	Air auxiliary heater plant
RD1	Relay (dual power supply only)	DI8	Remote on-off
4	Main power supply PDC 1PH (*)	DI9	Switch com. modbus
5	PDC 3PH main power supply (*)	DI10	Flow switch/plantaware
24V	24V power supply	PE	Grounding
D1	Dry contact return SG1	R	Phase1
+D1	Dry contact power supply SG1	S	Phase2
D2	Dry contact return SG2	T	Phase3

Continued

Ref.	Function	Ref.	Function
+D2	Dry contact power supply SG2	N	Neutral
GND	Grounding	L	T-Split board power supply line protected by fuse
D1	Summer/Winter switching	N	T-Split power supply neutral
DI4	No power supply	C	Electrical Connection DI8 - GND

(*) three-phase (3 ph) power connection excludes single-phase (1 ph) and vice versa

TAB. 40 (XS panel terminal board table)

13.13.2 ELECTRONIC BOARD SG-PROBE

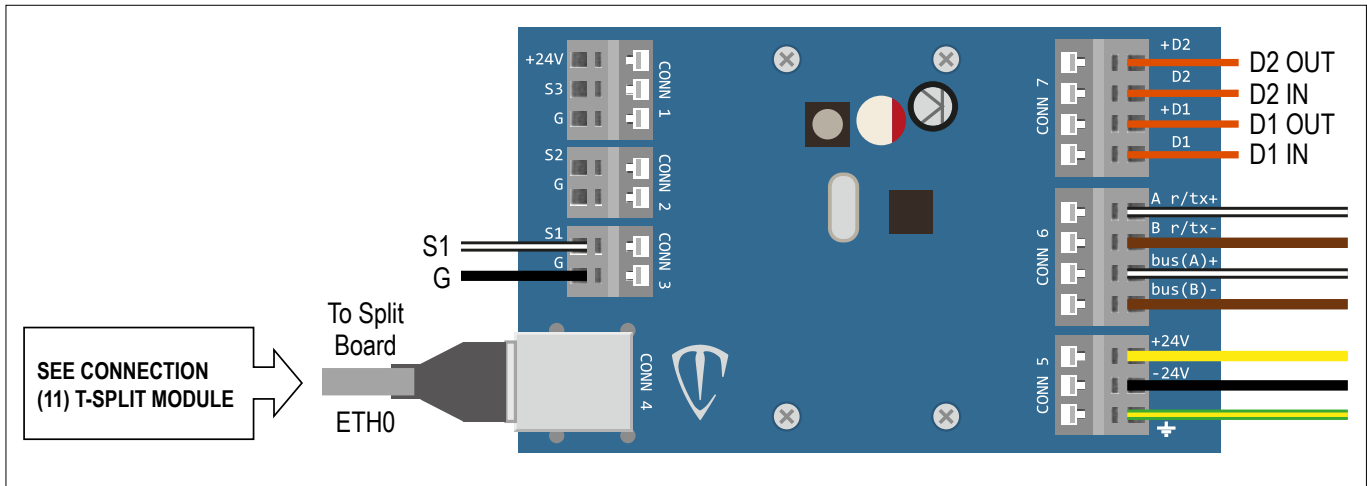

FIG. 61 (SG-Probe electronic board)

Ref.	Function	Ref.	Function
CONN 1	Optional probe input	CONN 5	24VDC Power Supply Input
CONN 2	Air exchanger probe input	CONN 6	Communication Bus Input
CONN 3	Plate exchanger probe input	CONN 7	SG-Ready Contact Input
CONN 4	RJ45 connector for T-Split board		

TAB. 41 (SG-Probe electronic board)

Ref.	Function	Ref.	Function
D1 OUT (+D1)	SG dry contact power supply	D2 IN	SG2 dry contact return
D1 IN	Dry contact return SG1	S1	Temperature output air/coolant gas exchanger
D2 OUT (+D2)	SG2 dry contact power supply	G	Ground probes S1

TAB. 42 (IN/OUT electronic card SG-Probe)

T-SPLIT MODULE

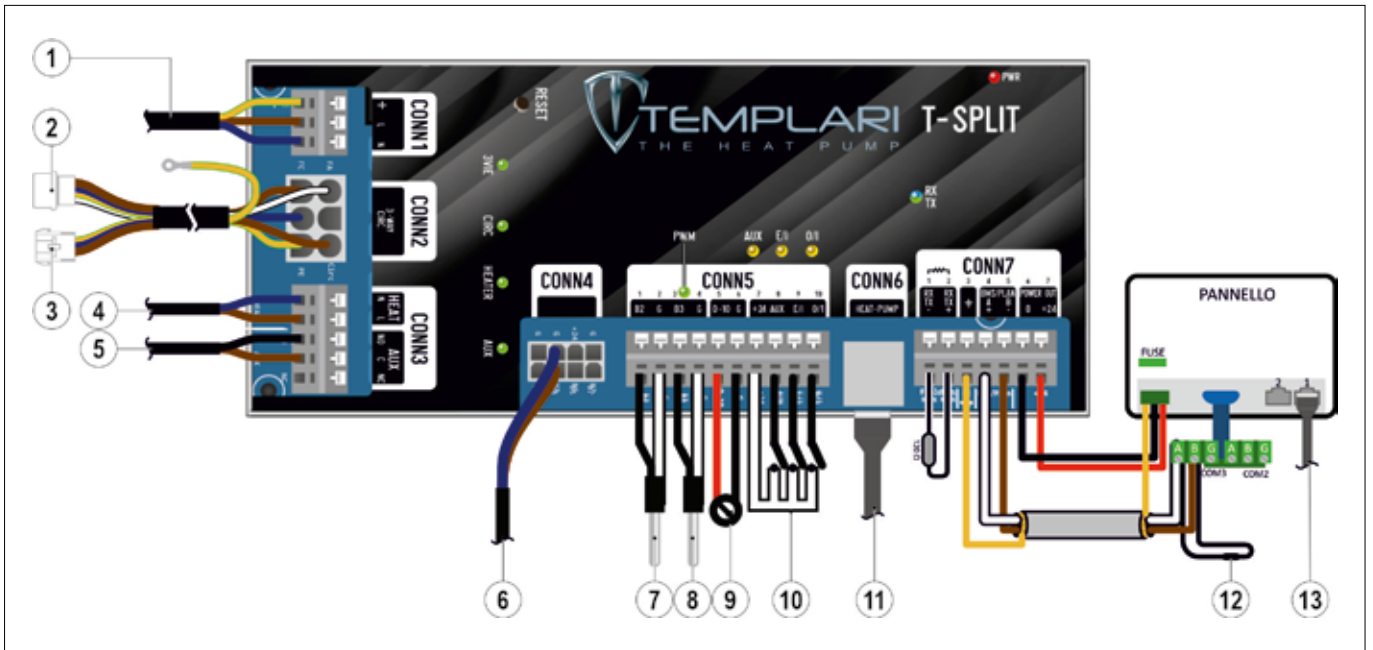

FIG. 62 (T-Split module)

Ref.	Function	Ref.	Function
1	230 V AC T-Split power supply from PDC electric panel SEE CONNECTION (2) TERMINAL BLOCK ELECTRIC PANEL	8	DHW probe
2	3 way valve connection	9	Optional 0/10 V input
3	230 VAC water pump power supply	10	Programmable clean contact inputs
4	230 VAC contactor power supply 1	11	RJ45 from HP terminal block SEE SG-PROBE ELECTRONIC BOARD CONNECTION
5	Dry contact for contactor power supply 2	12	Terminal resistor 120 Ω
6	PWM circulator	13	Modem / Router
7	System probe		

TAB. 43 (T-Split module)

13.13.3 PGD (SCREEN)

The SG-Ready function can be activated and configured via PGD from screens B11 and B12 (s. FIG. 54)

Minimum contact closing times (antibump) can be defined for inputs D1 (SG1) and D2 (SG2)

You can enable or disable the use of electrical heating elements for mode 4

Configuration for mode 3. Setpoint in mode 3, maximum absorbable power and related hysteresis

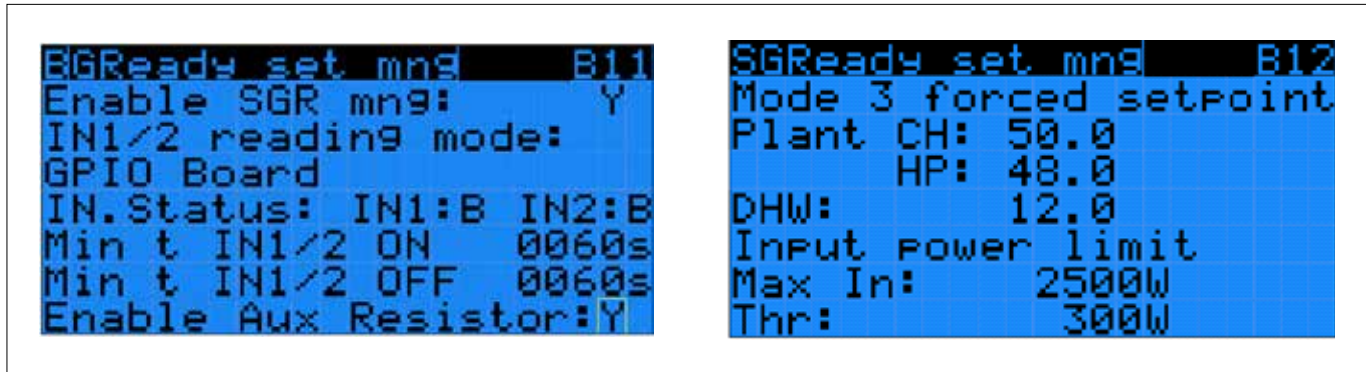

FIG. 63 (PGD screen B11 and B12)

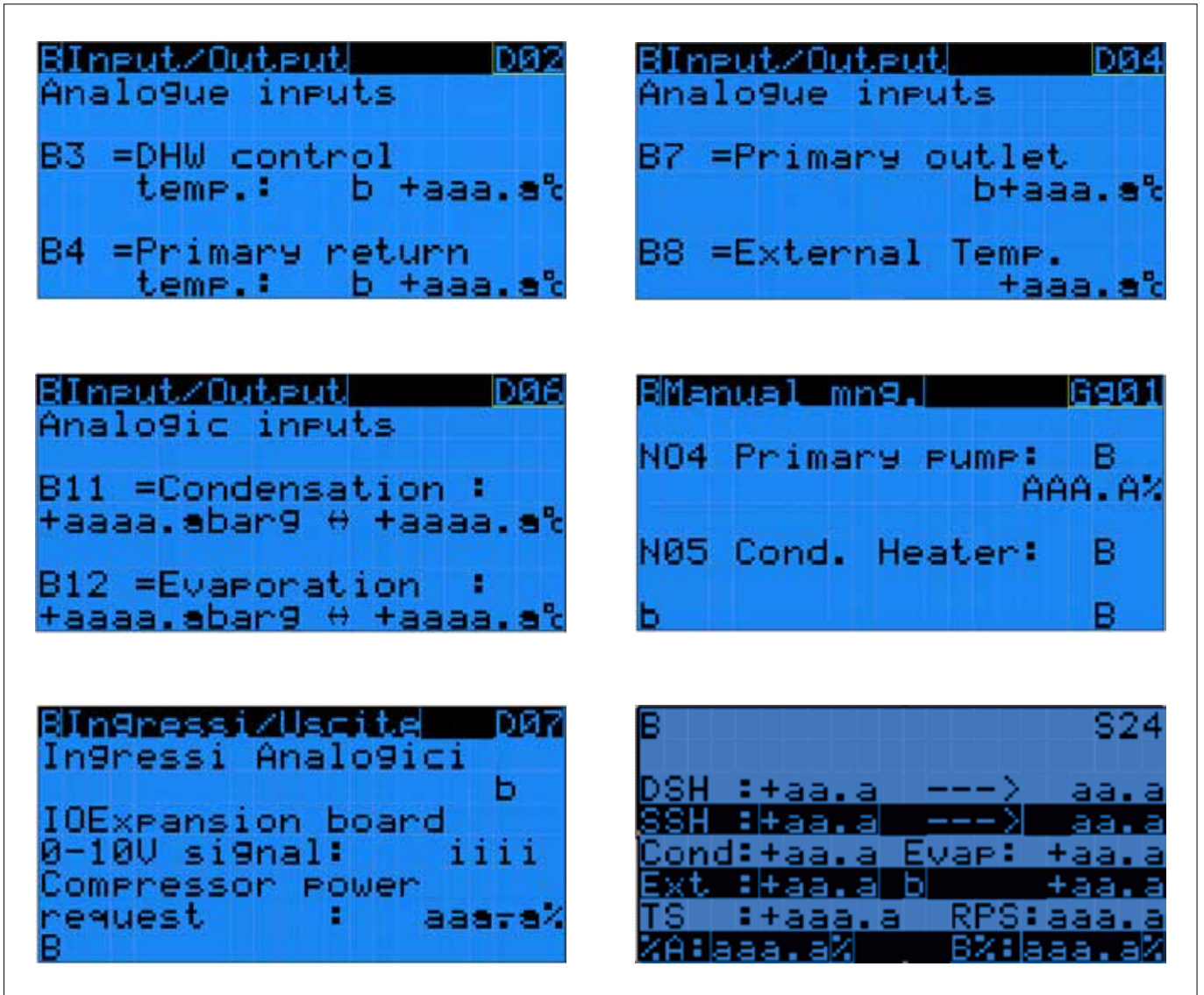

FIG. 64 (PGD - Screen)

14 USE OF THE MACHINE

14.1 CHECKS AND OPERATIONS BEFORE COMMISSIONING



⚠ DANGER

BEFORE USING THE MACHINE, THE AUTHORISED OPERATORS MUST READ ALL PARTS OF THIS MANUAL AND BE CERTAIN THEY HAVE UNDERSTOOD THEM.



⚠ WARNING

BEFORE EACH MACHINE START-UP IT IS MANDATORY TO PERFORM THE CHECKS AND THE OPERATIONS IN **TAB. 37**.

Ref.	Checks and operations before commissioning
1	Make sure the machine is complete in all its parts
2	Check the integrity and correct operation of the guards and protective devices (s. chap. 6)
3	Check that the filter is correctly connected in the return pipe of the PDC in order to avoid clogging or malfunction of the plate heat exchanger and make sure that it is clean
4	Make sure that any drain valves are closed
5	Make sure that the hydraulic system valves are open
6	Make sure that the machine power supply cables have a suitable section (s. TAB. 26)
7	Make sure that the appropriate electrical protection devices have been inserted

TAB. 44 (Checks and tasks in preparation for start-up)

14.2 STARTING THE MACHINE FOR TESTING



⚠ DANGER

BEFORE STARTING THE MACHINE YOU MUST READ ALL PARTS OF THIS MANUAL AND BE CERTAIN YOU HAVE UNDERSTOOD THEM.



⚠ WARNING

BEFORE EACH MACHINE START-UP IT IS MANDATORY TO PERFORM THE CHECKS AND THE OPERATIONS IN **PAR. 14.1**.



⚠ WARNING

AFTER POWERING THE MACHINE, IT WILL ACTIVATE THE AUTOMATIC OIL HEATING FUNCTION (THE DURATION OF THIS DEPENDS ON THE TIME NECESSARY TO BRING THE OIL CONTAINED IN THE COMPRESSOR TO TEMPERATURE, AND THEREFORE IS BASED ON THE STARTING TEMPERATURE).



Turn the main power switch (supplied by the customer) to **Pos. "I-ON"**

14.3 CHECKS AND OPERATIONS AFTER COMMISSIONING



⚠ DANGER

BEFORE USING THE MACHINE, THE AUTHORISED OPERATORS MUST READ ALL PARTS OF THIS MANUAL AND BE CERTAIN THEY HAVE UNDERSTOOD THEM.



14.4 TESTING

Each machine is tested by the manufacturer before delivery, however it is recommended to make a short break-in, in order not to excessively stress the new compressor. In this regard, it is advisable to operate the machine manually, leaving for at least one / two hours the revolutions of the compressor at an average value (50-60 %).

The procedures for testing at the machine installation site can be performed by remote control, both HCC (**s. par. 14.7**) and PGD (**s. par. 14.8**).

You need to know the procedure for accessing the advanced menus.

PGD: Press the PRG button ► Main menu ► G. Assistance ► g. Manual management ► enter ACCESS PASSWORD

HCC: Advanced screens ► ACCESS PASSWORD ► follow the same instructions indicated for the PGD from the "Main Menu" onwards;

For a more detailed description of the functions for remote panel and menu refer to the relevant sections of the manual (between **par. 14.8** - CONTROL TERMINAL and **par. 14.12** - MENU INPUTS/ OUTPUTS, referred to the draft correction CR02)

MINIMUM WATER FLOW CHECK:

It consists in checking the correct water circulation in the hydraulic circuit.

1) Access the page Gg01 (**s. FIG. 55**) (Main menu ► G. Service ► g. Manual management ► SERVICE PASSWORD ► screen. Gg01) N04: Primary pump, set manual "MAN", set the working % at "100.0".

Check the correct water circulation in the hydraulic circuit, it should be not less than the minimum alarm threshold **par. 5.8**. If the waterflow is less than the minimum alarm threshold, the machine goes into alarm (signalled by the red warning light on in the control panel or by a red triangle in the remote control).

In this case, to restore the correct water flow proceed as follows:

- check the real opening of the valves
- check for blockage (for example in the filter)
- check the absence of air in the pipes

If needed, remove the causes.

2) If the minimum flow is respected: screen Gg01 (**s. FIG. 55**) N04: Primary pump, set to automatic "AUT"

HEAT PUMP OPERATION CHECK:

1) Screen D02 (**s. FIG. 55**) and D04 (**s. FIG. 55**): check the probe B7 (outlet water temperature) and compare it with the probe B4 (inlet water temperature). Check that the circulator operates with a correct temperature difference (<8 °C)

2) Screen D06 (**s. FIG. 55**) e D04: check the probe B11 (condensation temperature) and the probe B7 (outlet water temperature). The difference between the two probes must be between 1 °C and 3 °C

3) Screen S24 (**s. FIG. 55**): check that the SH (superheating) value is between 5 °C and 9 °C

4) Main menu ► G. Service ► g. Manual management ► SERVICE PASSWORD ► screen Gg01 (**s. FIG. 55**): "N09 DHW 3W Valv", if a 3 ways valve for DHW (domestic hot water) is present set to manual MAN

5) Get back all settings from manual MAN to automatic AUT

6) During the production of domestic hot water (DHW), check that the machine performs it with priority over plant heating/cooling: the difference between the probe B7 (outlet water temperature) and the probe B3 (domestic hot water temperature, the probe must be placed at the top of the tank) must not be higher than 3°C.

7) Check that voltage and frequency are within the following ranges.

- single-phase: 230 V 50 Hz (± 6%)
- three-phase: 400 V 50 Hz (± 6%)

Some malfunctions can be detected during startup:

1) possible high pressure alarm (especially during high temperature water production)

It can occur when the difference B11-B7 between the values measured by probes B7 (outlet water temperature) and B11 (condensation temperature) is >5 °C.

If B11-B7 is >5 °C check the following:

- presence of air in the refrigeration circuit
- presence of air in the hydraulic circuit

In order to increase the machine lifespan, it is recommended that the difference B11-B7, depending on the thermal load and the water flow on the plant side, should be between 1.5 °C and 3 °C.

2) electronic expansion valve continuously 100% open

Possible causes:

- lack of refrigerant gas in the refrigeration system (in this case the electronic valve remains open above normal values to compensate for the lack of gas)
- heat pump used incorrectly (example: installation of an undersized heat pump)

Possible solutions:

- check the correct valve operation
- check that the right gas amount is present in the heat pump
- replace the heat pump if it is undersized compared to the building thermal need.

14.5 K-TOUCH PANEL

14.5.1 GENERAL NOTICES

⚠ WARNING

IN ORDER TO MONITOR THE PANEL REMOTELY USING A VNC PROGRAM, THE HOME MUST HAVE INTERNET ACCESS, AND THE K-TOUCH PANEL MUST BE PHYSICALLY CONNECTED VIA NETWORK CABLE TO THE HOME ROUTER OR SWITCH.

THE PANEL COMES WITH THE “**EASY ACCESS**” FUNCTION ALREADY ACTIVE, WHICH LASTS FOR THE LIFE OF THE PANEL. BY USING A SPECIFIC CLIENT, THIS FUNCTION ALLOWS REMOTE ACCESS TO THE PANEL USING A PC OR A SMARTPHONE WITHOUT FURTHER CONFIGURATIONS, SIMPLY BY ENTERING THE **USER NAME AND PASSWORD OF THE EASY ACCESS ACCOUNT**.

THE ACCESS CREDENTIALS ARE PROVIDED BY EMAIL TO THE CUSTOMER AT THE TIME OF ACTIVATION.

FOR THIS REASON, A VALID EMAIL ADDRESS FOR RECEIVING ALL THE NECESSARY INFORMATION MUST BE PROVIDED AT THE TIME OF PURCHASE.

14.5.2 PREPARING THE MACHINE FOR CONNECTING THE K-TOUCH PANEL

⚠ WARNING

THE K-TOUCH PANEL MUST BE POWERED EXCLUSIVELY BY THE INTERNAL POWER SUPPLY ON THE MACHINE, ACCESSIBLE FROM THE TERMINALS OF THE T-SPLIT MODULE (CONN7) (**S. FIG. 46, FIG. 51, FIG. 57 AND FIG. 58**) OR FROM THE APPROPRIATE TERMINALS ON THE ELECTRICAL PANEL (**S. FIG. 45**), OTHERWISE THE WARRANTY WILL BE VOID.

MODBUS cable type: Templar HCC cable (type Belden 3105A 2x22AWG shielded)

Power supply cable type: 2x1 mm²

Power supply type: HCC POW 24 VDC, 2.5 A

Prepare the electrical system for the laying of ducts of at least 16 mm in diameter for laying the cable only MODBUS and power supply for sensors and peripherals.

The connections between the T-Split module and the K-Touch Panel must follow the connections shown in **FIG. 46**. The K-Touch panel can be connected ELECTRICALLY to the P-LAN network of the µPC or to the BMS port, according to the **TAB. 38**.

Be sure to connect the earthing pole of the K-Touch Panel to the shielding of the Modbus data network, and the latter to the PE pole of the CONN7 terminal board of the T-SPLIT module or of an earthing terminal of the electrical panel inside the PDC (s. **FIG. 57**)



INFORMATION	
THE SHIELDING OF THE VARIOUS CABLE SECTIONS, BETWEEN THE DIFFERENT POSSIBLE PERIPHERALS, MUST BE CONNECTED IN SERIES AND NOT INSERTED IN THE G POLE OF EACH PERIPHERAL, AS IN FIG. 57 AND FIG. 58 .	
CAUTION: THE BMS CONNECTION IS AN ALTERNATIVE TO THE P-LAN CONNECTION. ONLY THE P-LAN CONNECTION PROVIDES FOR THE CONNECTION OF THE DI9 TO GND (S. FIG. 56).	

BMS or P-LAN		T-SPLIT CONN7	BUS CABLE	K-Touch	HCC Peripherals
BMS	P-LAN				
PE PDC	PE PDC	PE	SHIELDING	EARTHING POLE	
+	RXTX+	+ A	A	A	A
-	RXTX-	- B	B	B	B

TAB. 45 (Electrical connection of the low line between PDC and K-Touch)

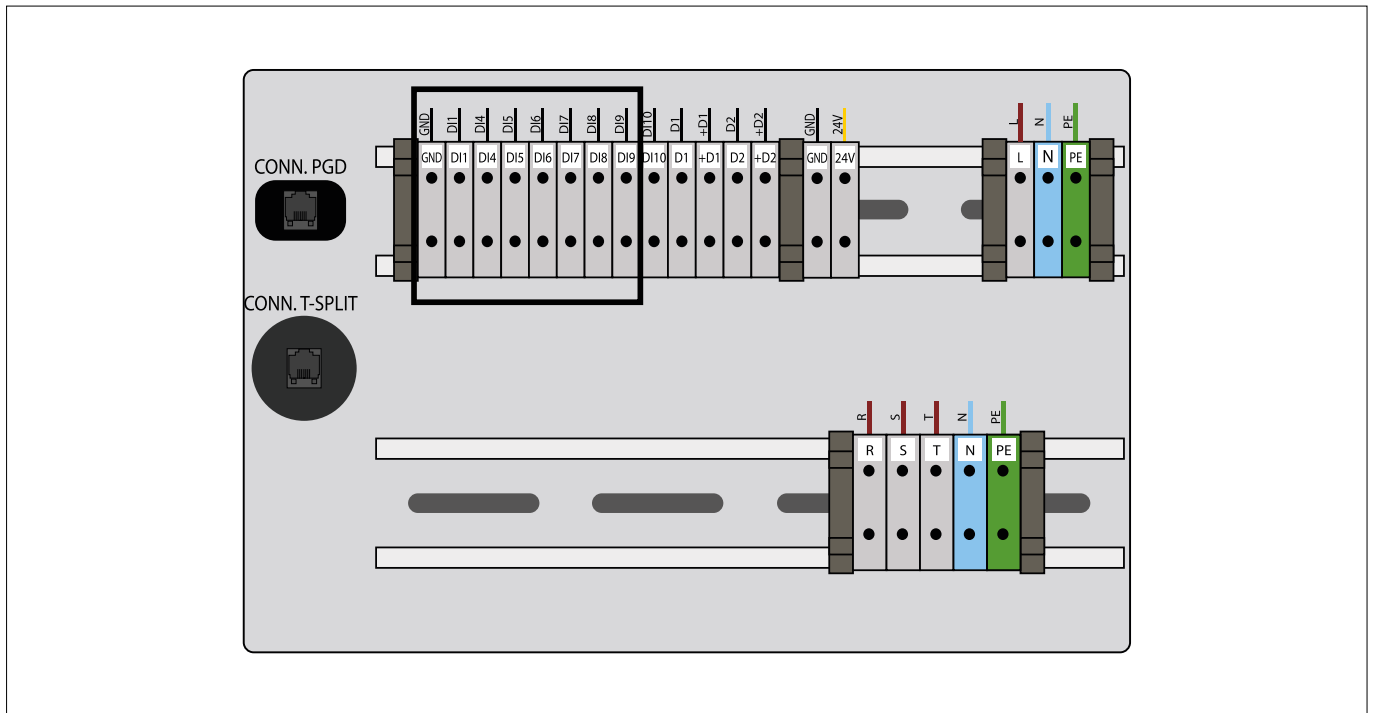

FIG. 65 (DI9-GND electrical connection in case of bus connection on P-LAN)

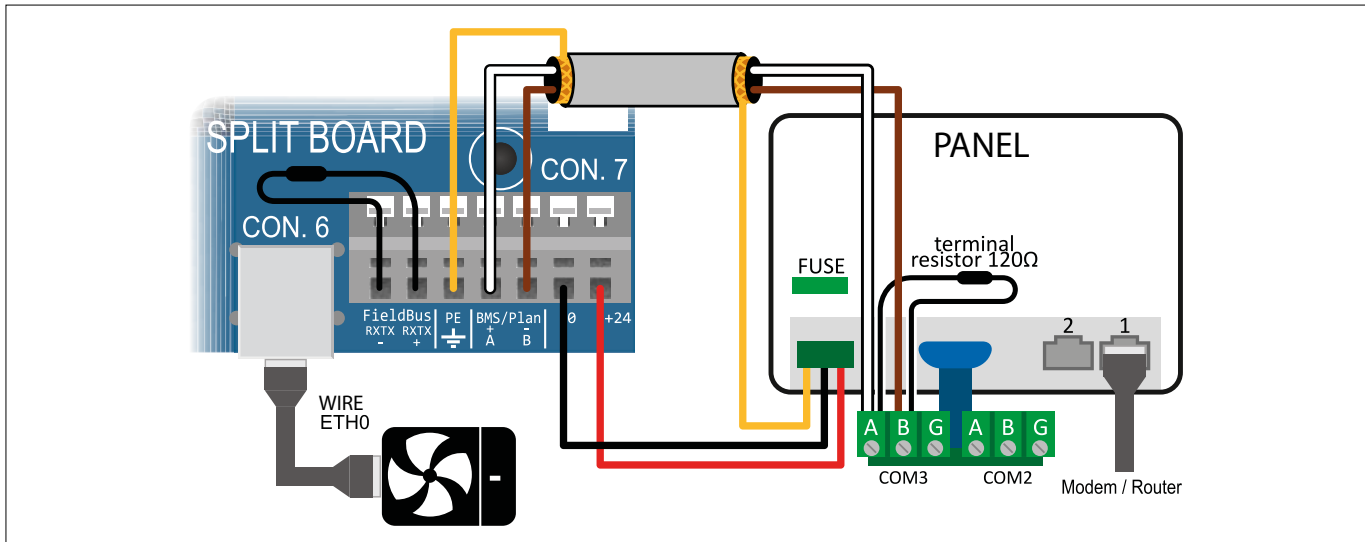

FIG. 66 (Connection K-Touch)

⚠ WARNING

IF MULTIPLE PERIPHERALS ARE INSTALLED, THE MODBUS DATA WIRING MUST NEVER UNDER ANY CIRCUMSTANCES BE PERFORMED WITH DIRECT LEADS THAT FORM Y CONNECTIONS OR STARS.

THE CONNECTION BETWEEN ONE PERIPHERAL AND THE NEXT MUST BE IMPLEMENTED THROUGH "CHAIN" CONNECTIONS, CONNECTING THE SENSORS AND MODBUS PERIPHERALS IN SEQUENCE. IT IS THEREFORE CONVENIENT TO ARRANGE THE THREADING OF THE CABLES FOR PASSING 2 MODBUS DATA CABLES; THE FIRST IS FOR THE DEVICE IN QUESTION AND THE SECOND WILL BE THE RETURN TO CONNECT THE NEXT DEVICE.

EACH DUCT THAT WILL END ON A PERIPHERAL DEVICE WILL THEREFORE HAVE 3 WIRINGS INSIDE:

2 BUS CABLES (ONE OUTWARD PLUS ONE RETURN), PLUS A POWER SUPPLY CABLE CONSISTING OF 2 WIRES OF 2X1 mm².

EXCEPTIONS ARE THE 2 TERMINAL PERIPHERALS (USUALLY, THE HEAT PUMP AND THE K-TOUCH PANEL), WHICH WILL HAVE ONLY ONE BUS CABLE AND ONE POWER CABLE INSTEAD.

FOR DATA LINES LESS THAN 10 m IN LENGTH, USE ONLY ONE **120 OHM** TERMINATION RESISTOR: THE ONE ON BOARD THE BMS OR THE ONE ON THE LAST PERIPHERAL IN THE CHAIN.

TO USE THE K-TOUCH REMOTELY, VIA A VNC PROGRAM, YOU MUST CONNECT THE RJ45 (LAN1) PORT ON THE BACK OF THE K-TOUCH PANEL TO A ROUTER OR SWITCH, VIA AN ETHERNET CABLE.

⚠ WARNING

THE BUS NETWORK MUST ALWAYS TERMINATE AT THE ENDS WITH A **120 Ω** RESISTANCE BETWEEN TERMINALS **A** AND **B**. THE ENDS OF THE NETWORK ARE USUALLY THE K-TOUCH PANEL ON ONE SIDE AND THE MACHINE ON THE OTHER.

IF THE PLANT REQUIRES THE MACHINE TO BE CONNECTED DIRECTLY TO A RADIANT SYSTEM ON THE FLOOR, CEILING OR WALL WITHOUT INTERMEDIATE SYSTEMS, THE ABSENCE OF CONDENSATION IS NOT GUARANTEED.

14.6 CONNECTION TO THE KITA HEAT PUMP

If you want to use the PGD remote control panel at the same time as the K-Touch panel, you must have a BMS board, which can be purchased separately.

If the BMS board is installed, a resistance of **120 Ω** must be connected to the MODBUS connection terminals. To allow the K-Touch panel to operate correctly, set the MODBUS RTU 485 communication protocol via the PGD panel (screen Ge01).

Regarding the μ PC, make sure you have not connected the ID09 terminal to GND (s. FIG. 45).

With this configuration, the PGD control panel and the K-Touch Panel can be used simultaneously.

If the K-Touch panel is the only display present and is connected to the machine via the P-LAN port, then the ID9 contact of the μ PC board must be connected to the Earth.

14.7 HCC CONNECTION (EXAMPLE)

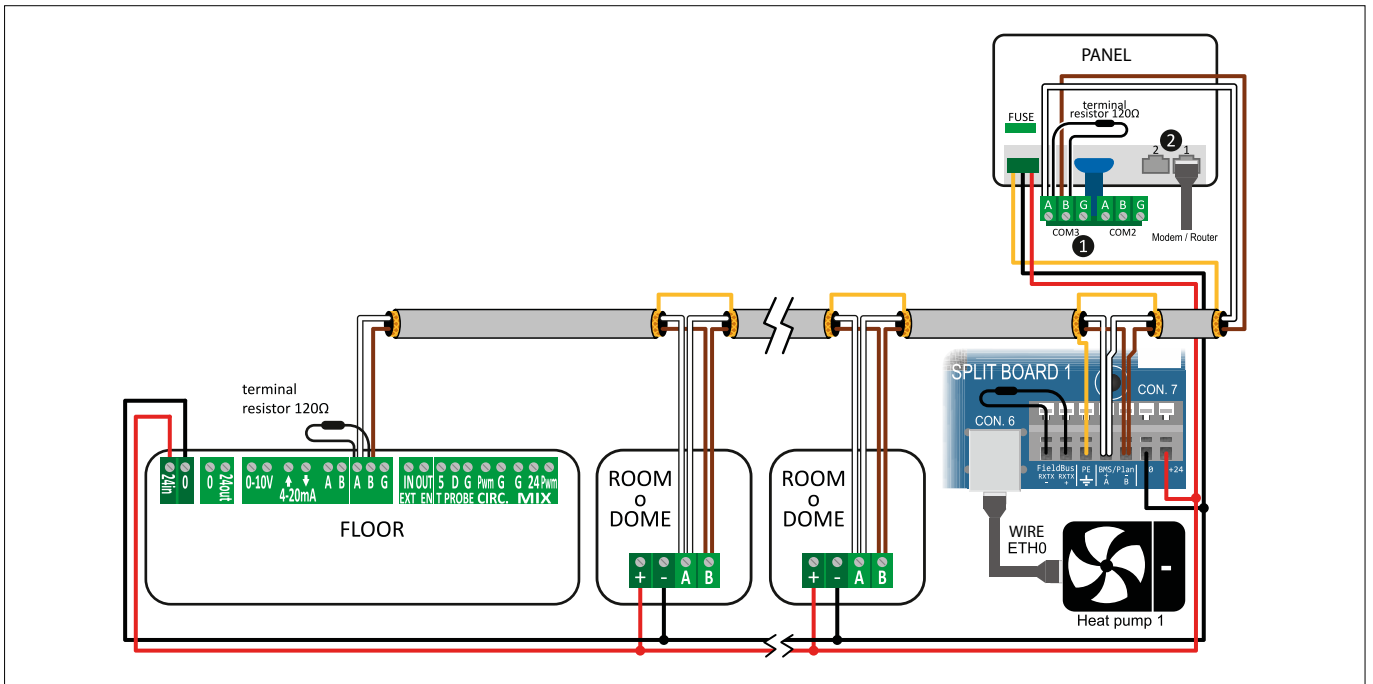

FIG. 67 (HCC Connection - Example)

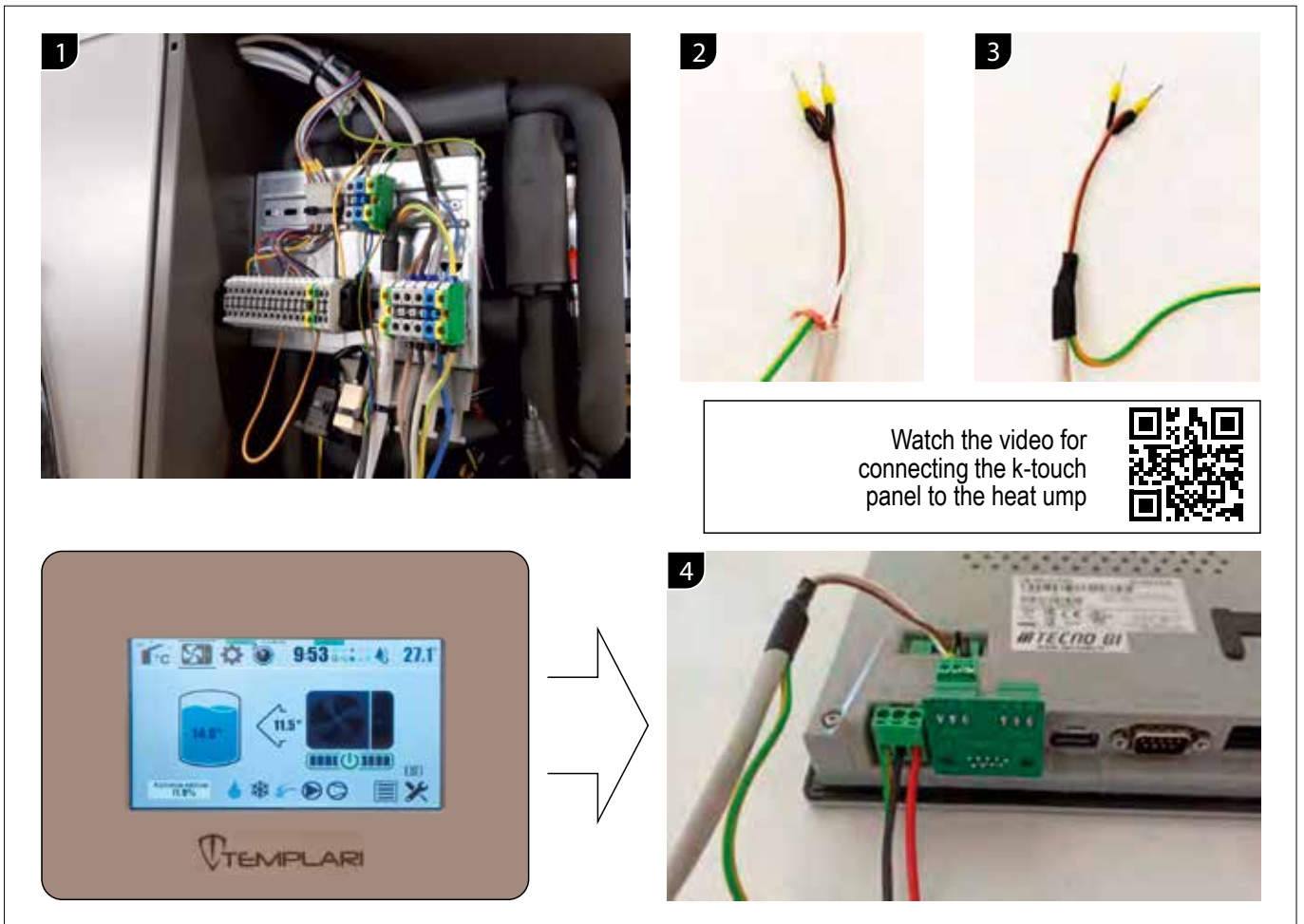

FIG. 68 (P-LAN connection 7a and BMS connection 7b)

14.8 PGD CONTROL TERMINAL (OPTIONAL)

The unit terminal is connected in serial via P-LAN line and is used remotely (technical room or home) to control the unit. In the control software, all the necessary adjustments have been implemented to guarantee the functionality and safety of the machine. Using the terminal, you can monitor the operation of the unit and set the operating preference parameters (summer/winter setpoint...).

The following figures are examples of how to use the control and drive the machine.

14.8.1 FASTENING THE TERMINAL

Proceed as follows to fasten the panel:

- 1) Attach the rear housing (FIG. 60 - Ref. 1) to the standard box or to the wall
- 2) Connect the telephone cable to the panel
- 3) Fix the front (FIG. 60 - Ref. 2) to the rear housing (FIG. 60 - Ref. 1) using the screws supplied with the kit
- 4) Install the snap frame (FIG. 60 - Ref. 3)

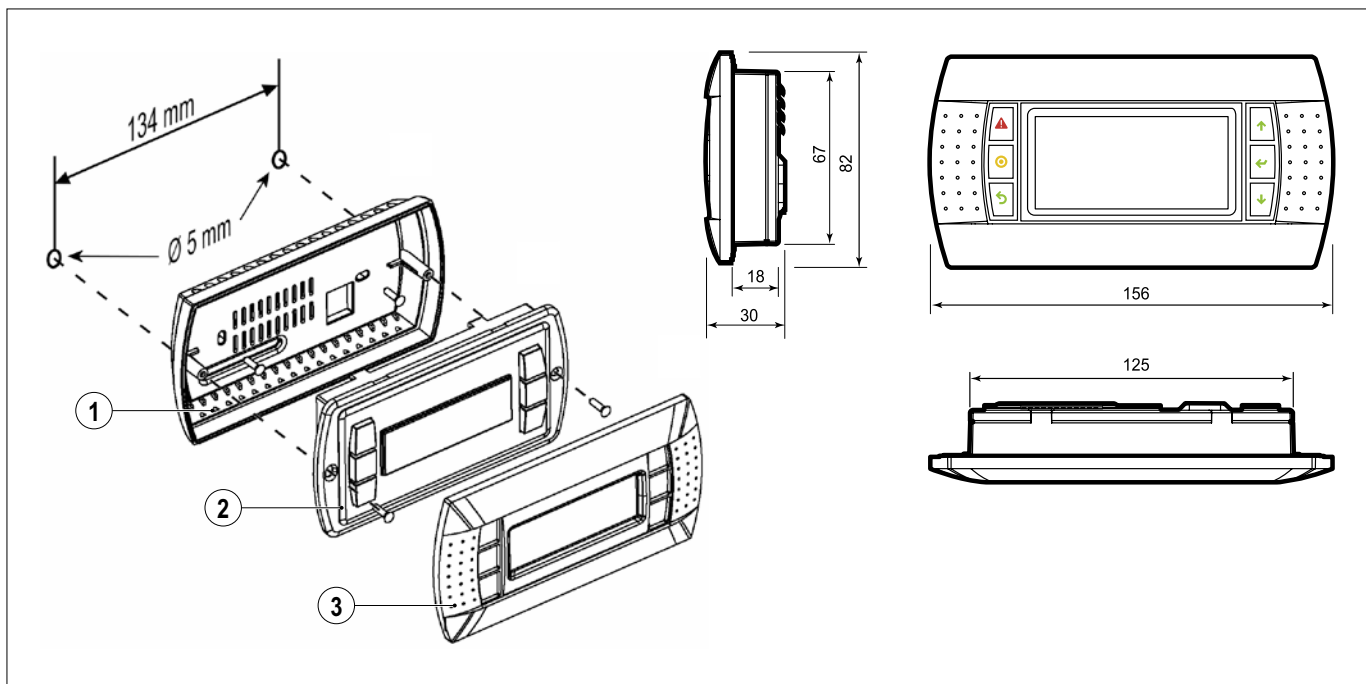

FIG. 69 (Fastening the terminal)

14.8.2 TERMINAL FUNCTIONS

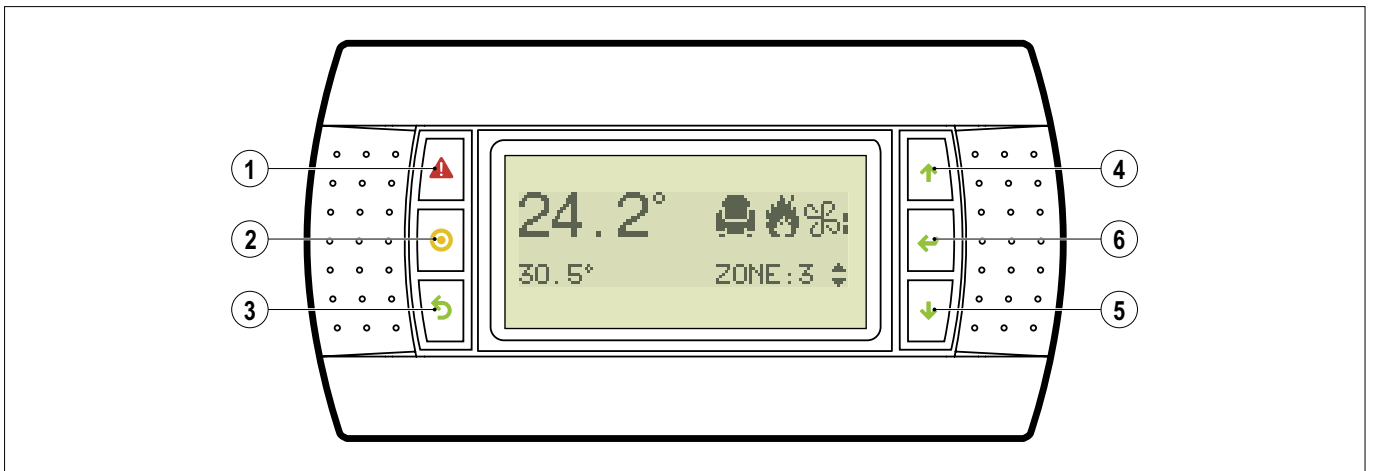

FIG. 70 (Terminal functions)

Ref.	Designation	Symbol	Function
1	“Alarm” button		Shows a list of active alarms
2	“Prg” button (open menu)		Allows you to enter the main menu
3	“Esc” button (go back or exit)		Goes back to the previous screen
4	“Up” button		Scroll up a list or increase the value shown on the display
5	“Down” button		Scroll down a list or decrease the value shown on the display
6	“Enter” button		Enter the selected submenu or confirm the set value

TAB. 46 (Terminal functions)

14.8.3 TERMINAL DISPLAY

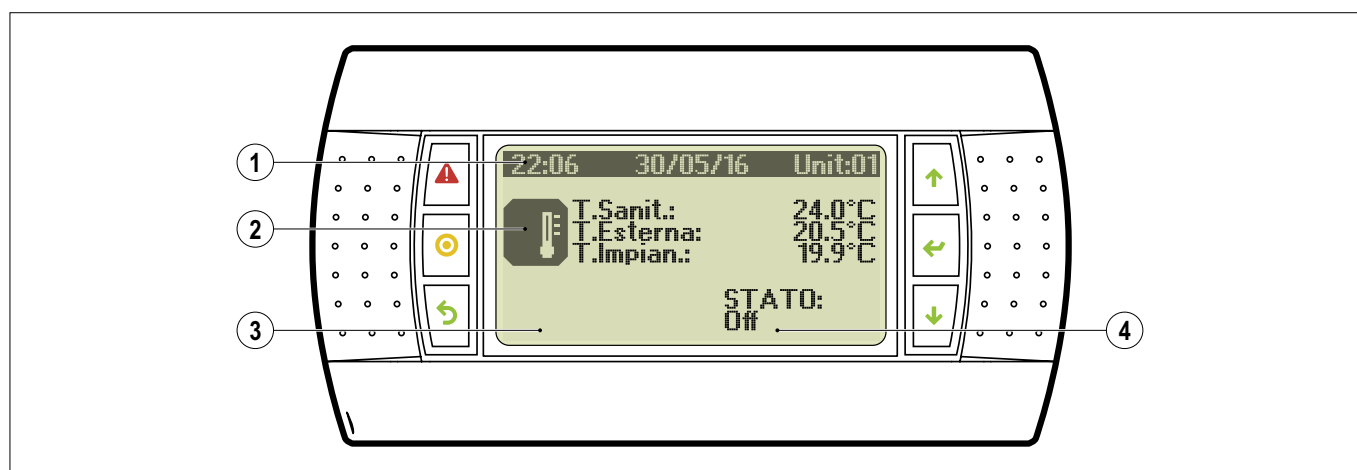

FIG. 71 (Terminal display)

Ref.	Designation	Function
1	Date and time and unit field	Shows the date and time and the connected unit
2	Quantities and requests field	Indicates the main quantities and the active request (s. TAB. 41)
3	Active Actuators field	Indicates active actuators (s. TAB. 42)
4	Unit status field	Shows the current unit status (s. TAB. 41)

TAB. 47 (Terminal display)

Symbol	Meaning
	No requests active
	Domestic hot water request active
	Request for hot water from primary circuit
	Request for cold water from primary circuit
	Total recovery: request for DHW + cold water from primary circuit

TAB. 48 (Main quantities and active requests)

Symbol	Meaning
	It is activated simultaneously with start-up of the compressor(s)
	It is activated if there is a request for heating of domestic hot water
	It is activated when one of the system pumps is on, except for solar collector pumps
	It is activated if solar collectors are installed and active
	It is activated if the plant integration system (heating element or boiler) is operating. If the "solar collectors" icon is active at the same time, only the latter is displayed.
	It is activated when a defrost is in progress, as an alternative to the 2 icons shown above

TAB. 49 (Actuators)

Unit status	Meaning
OFF	The machine is in standby mode: the antifreeze function remains active (activation of the internal circulator and, if required due to excessive external temperatures, activation of the compressor), while the adjustment based on system request is not active
ON	All the functions are active and the machine adjusts according to the system request
ENERGY S.	All functions are active and the machine adjusts according to a “reduced” setpoint (which can be set from screen B02, see below). This state allows energy savings
AUTO-OFF	The machine adjusts according to the set time slots (screen C02) and following the nominal setpoint (can be set from screen B01). The machine is in OFF status
AUTO-ON	The machine adjusts according to the set time slots (screen C02) and following the nominal setpoint (can be set from screen B01). The machine is in ON status
AUTO-E.S.	The machine adjusts according to the set time slots (screen C02) and following the Energy Saving setpoint (which can be set from screen B02)
Din-OFF	The machine is switched off by an input digital contact (if provided)
BMS-OFF	The machine is switched off by a BMS supervisor (if provided)
ALARM-OFF	Machine is in off status due to an alarm
PROTECT	Antifreeze function for harsh outdoor temperatures and system temperature too low: the compressor is active until a system temperature of 40°C is reached
AUTOMATIC BOILER MANAGEMENT IF REQUIRED	Boiler start-up is automatically managed by the heat pump control









TAB. 50 (Unit status)

14.9 MAIN MENU

To enter the menu press the “**Prg**” button.

Press the “**Up**” and “**Down**” buttons to navigate the menu (s. FIG. 63).

When all operations have been carried out, press “**Esc**” to return to the main screen.

Ref.	Symbol	Meaning	Ref.	Symbol	Meaning
A		Unit On-Off	E		Alarms log
B		Setpoint	F		Card change
C		Clock/Time slots	G		Service
D		Inputs/Outputs	H		Manufacturer

TAB. 51 (Terminal display)

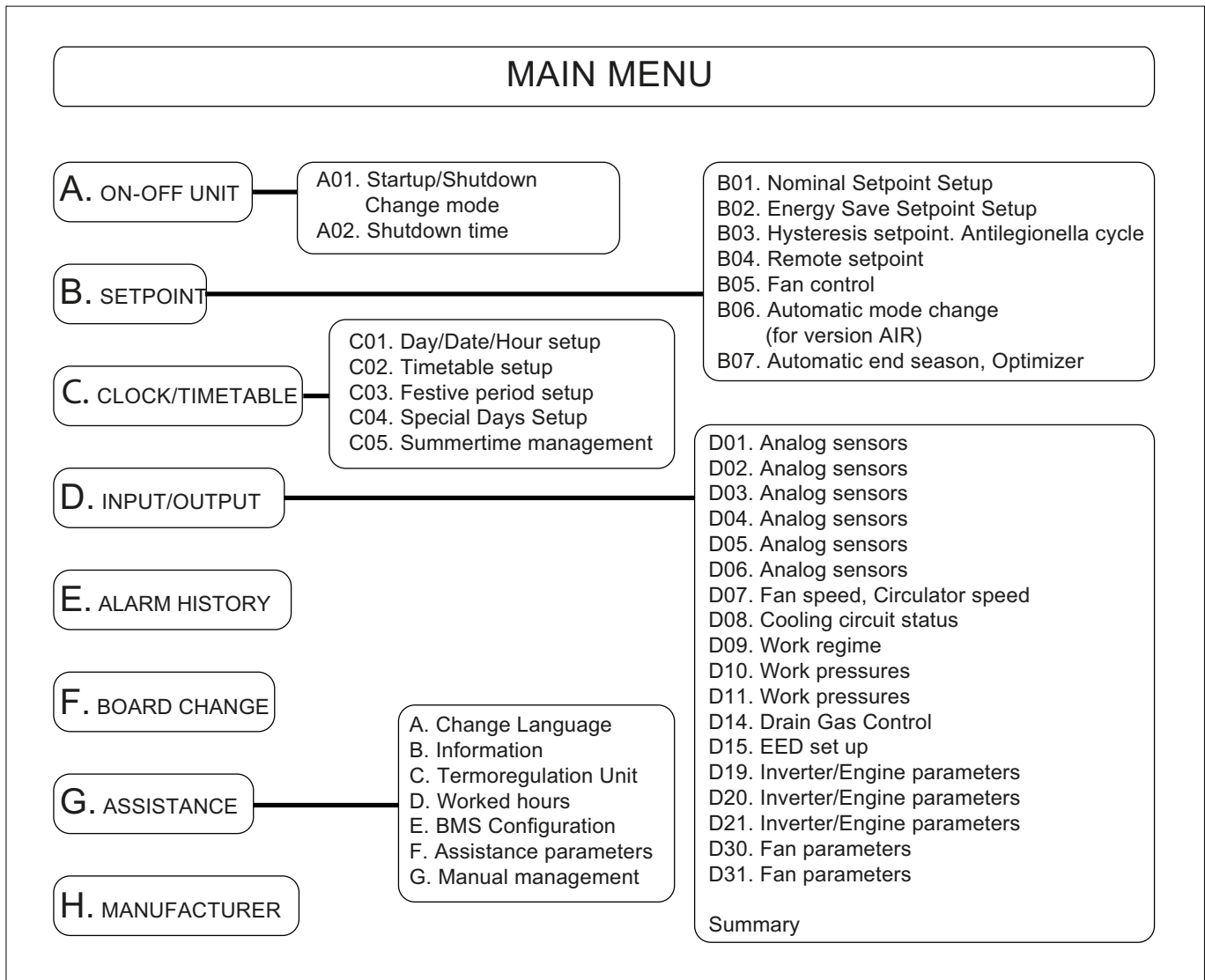

FIG. 72 (Menu overview)

14.10 ON-OFF MENU

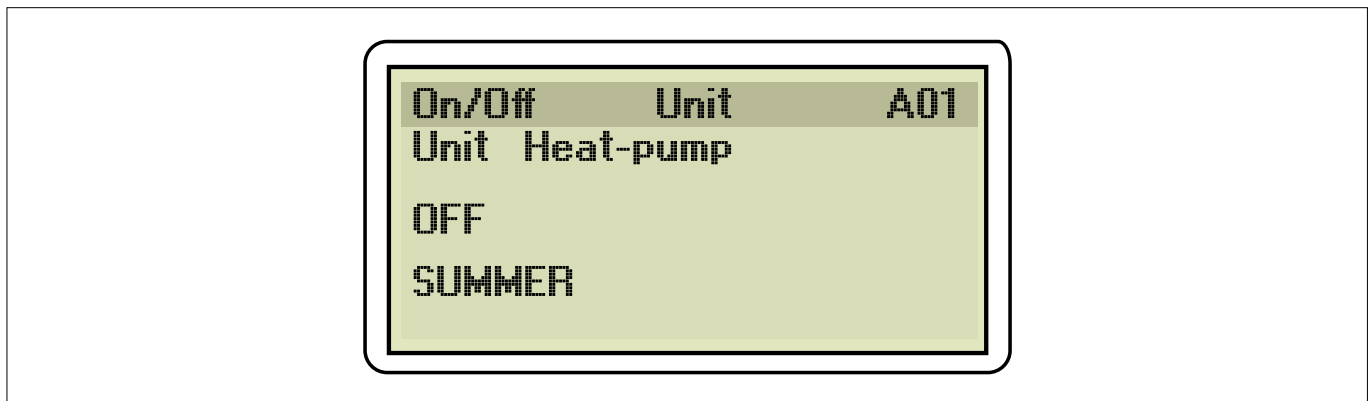

FIG. 73 (ON-OFF menu)

Screen A01: allows you to set the status and operating mode. The OFF status set in this menu is always conditional (e.g. antifreeze activation).

Screen A02: Shuts down the pump unconditionally for a certain period of time. Once the time has elapsed, the A01 function is re-enabled.

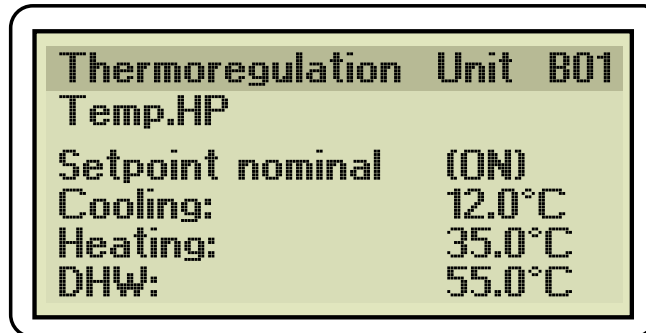

FIG. 74 (Setpoint menu)

Screen B01: Changing nominal setpoints.

Screen B02: Changing Energy Saving setpoints. We recommend the use of Energy Saving at night or during prolonged absences from home. To reduce the unit's consumption, it is advisable to use the climate curve instead of setting the Setpoints, since this allows continuous supply.

Screen B03: allows you to activate programming of the anti-Legionella cycles. The recommended setpoint is 70°C, as per factory data.

Screen B05: allows you to choose the fan operating mode

You can choose from the following states:

- **POWERFUL:** the most efficient condition. However, it also involves greater fan noise.
- **NORMAL:** the operating condition set by the manufacturer. It allows an excellent compromise between efficiency and noise.
- **QUIET1 - QUIET2 - SILENT:** in these operating conditions the fan is slowed down by 10, 15 or 20 percentage points respectively. These conditions make it possible to work with less and less noise. It should be noted that setting these functions also gradually decreases the efficiency of the machine.

Screen B06: Only in the AIR version. Automatic Mode change to switch from cooling mode to heating mode, defining a comfort zone inside which neither of the 2 modes is active. For the function to be activated, the difference between the cooling and heating setpoints must be equal to the Comfort Delta. It also allows you to set the operating mode for the internal fan. The internal fan can follow low, medium or high demand (compressor speed) or control condensation.

Screen B07: manages Automatic End of Season The average daily outdoor temperature above which the heating function is to be switched off and below which it is to be switched back on must be set; if present, the DHW function remains active regardless.

- **En. AUTO Change:** enables or disables the function.
- **HP Off Ext. T.:** the average outdoor temperature above which heating is switched off.
- **HP On Ext. T.:** the average outdoor temperature below which heating is reactivated.
- **Average Outdoor Temperature:** shows the average of the current outdoor temperature.

Screen B08: optimizer management. The optimizer is an algorithm used to store energy by exploiting the thermal inertia of the building when conditions are more favourable.

- **Active Optimizer:** enables or disables the function.
- **Final setpoint:** shows the value the heat pump is aiming for, including the Optimizer Delta.

- Delta Optimizer: shows the delta (positive or negative) due to the optimization algorithm.
- Influence: sets the minimum (negative delta) and maximum (positive delta) values. This function is used to limit the influence of the optimizer if necessary.

Screen B09: allows you to set a shutdown hysteresis. Once the Setpoint has been reached, instead of shutting down, the machine continues to work at a minimum until this target is reached on the setpoint that has been set.

If in the meantime the demand increases again (e.g. request from the DHW), the compressor returns to the required operating regime.

14.11 CLOCK/TIME SLOTS MENU

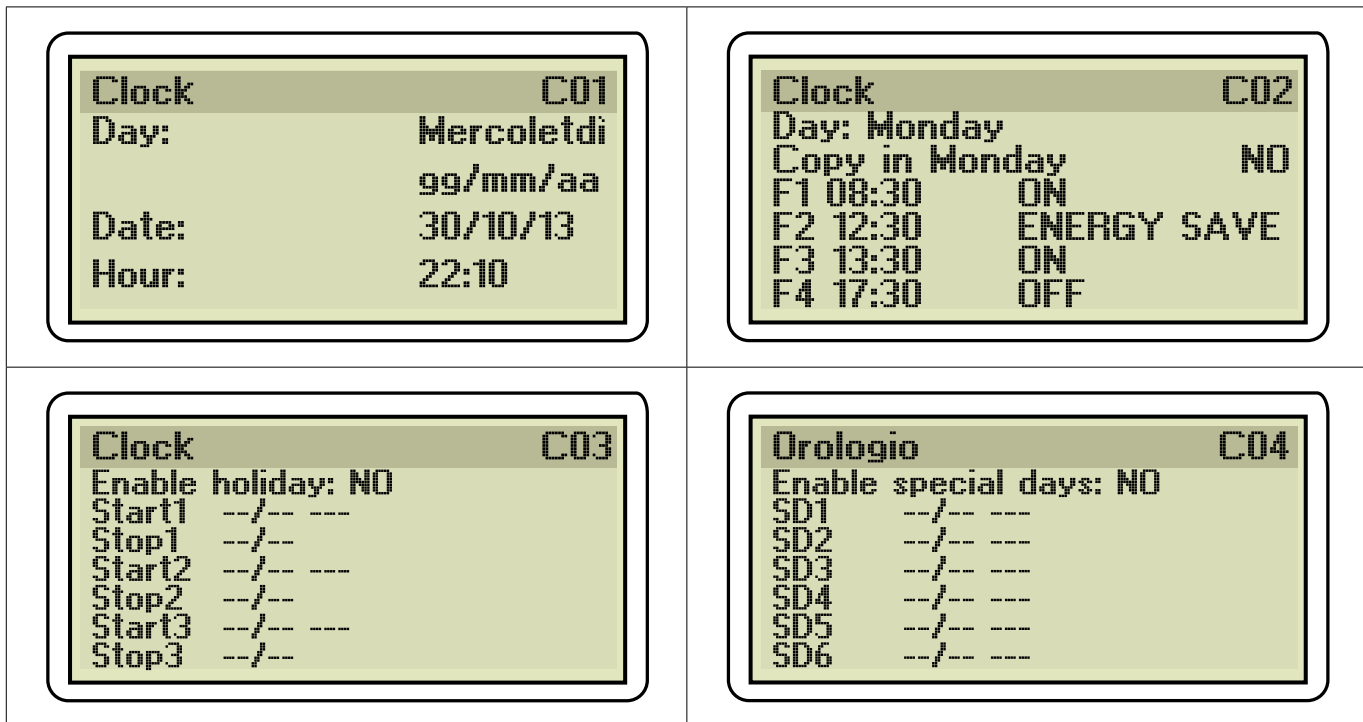

FIG. 75 (Clock/Time slots menu)

Screen C01: Date and time setting.

Screen C02: Allows you to set the time slots.

To access modification of the time slots, set OFF or AUTO status from the ON-OFF menu.

Press the **“Enter”** button to choose the day for which you want to set the time slots.

Use the **“Up”** and **“Down”** buttons to change the value displayed.

Confirm with the **“Enter”** button.

Press the **“Enter”** button twice to switch to time slot setting:

- F1: means the time slot between 00:00 on the selected day to the time set in F1.
- F2: means the time slot between the time set in F1 and the time set in F2.
- F3: means the time slot between the time set in F2 and the time set in F3.
- F4: means the time slot between the time set in F3 and the time set in F4.

After entering the time in the first time slot, confirm with the **“Enter”** button to set the desired operating mode in the time slot in question (choose between ON - OFF- ENERGY SAVE).

Confirm the choice with the **“Enter”** button and proceed with setting the other time slots.

To set the times on the other days, press the **“Enter”** button and proceed as explained above.

Otherwise you can copy the setting on several days: once you enter the C02 screen,

- Press the **“Enter”** button to access the choice of the day you want to copy
- Then use the **“Up”** and **“Down”** buttons to select the day
- Confirm with the **“Enter”** button

- Use the “**Up**” and “**Down**” buttons to choose the day to which you want to copy the time slots
- Confirm with the “**Enter**” button
- Using the “**Down**” button, choose YES and confirm with the “**Enter**” button

Screen C03: Allows you to enable three periods with preset operation.

- Press the “**Enter**” button and the “**Down**” button to enable/disable the period(s).
 - Confirm with the “**Enter**” button to access the choice of the starting day of the particular period.
 - Use the “**Up**” and “**Down**” buttons to choose the starting day.
 - Confirm the choice with the “**Enter**” button
 - Choose the operating mode with the “**Up**” and “**Down**” buttons
 - Confirm with the “**Enter**” button
 - Use the “**Up**” and “**Down**” buttons to choose the final day.
 - Confirm the choice with the “**Enter**” button
 - Repeat the same actions to set the remaining periods if necessary.
- Press the “**Esc**” button to return to the menu.

Screen C04: Allows you to enable a preset operation for a maximum of 6 different days.

- Press the “**Enter**” button and the “**Down**” button to enable/disable the special day(s).
 - Confirm with the “**Enter**” button to access the choice of the starting day of the particular period.
 - Use the “**Up**” and “**Down**” buttons to choose the starting day.
 - Confirm the choice with the “**Enter**” button
 - Choose the operating mode with the “**Up**” and “**Down**” buttons
 - Confirm with the “**Enter**” button
 - Repeat the same actions to set the remaining special days if necessary.
- Press the “**Esc**” button to return to the menu.

Screen C05: Enables automatic transition from daylight saving time to summer time. The parameters are initially set by the manufacturer.

14.12 INPUTS/OUTPUTS MENU

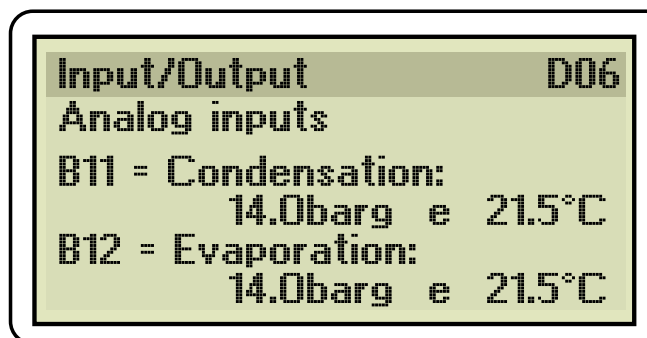

FIG. 76 (Inputs/Outputs menu)

Accessing this menu allows you to read multiple values.

The following probes can be read from screen D01 to screen D06:

- B1:** difference between the primary delivery temperature and the return liquid temperature from the plate heat exchanger: represents SUBCOOLING in the heat pump (heating) operation.
- B2:** temperature of the probe to be inserted into the system puffer. If the NoPuffer function is activated (from the Service menu), probe B2 is ignored.
- B3:** DHW temperature probe to be inserted in the upper part of the DHW boiler. If there is only one tank that works both on the system and on DHW, only one probe should be used.
- B4:** system return temperature.

- B5:** flow rate read by the flowmeter.
- B6:** compressor head temperature
- B7:** water/refrigerant gas plate heat exchanger delivery temperature probe.
- B8:** external air temperature.
- B9:** compressor delivery temperature.
- B10:** compressor intake temperature.
- B11:** condensation pressure and corresponding temperature.
- B12:** evaporation pressure and corresponding temperature.

Screen D07: fan speed and circulator speed management.

Screen D08: view the status of the Refrigeration Circuit: opening percentage of the electronic expansion valve, B10, B12.

Screen D09: view of the operating regime.

- Required capacity.
- Real capacity.
- Compressor speed.
- ON waiting time: Minimum time between one shutdown and another, or time needed to equalize the high and low pressures to the correct starting value. Screen D10: the work area inside the envelope and the “out of envelope” alarm countdown are indicated.

Screen D11: shows information on pressures.

- difference between high and low pressure
- ratio between high and low pressure
- “delta P low” alarm countdown

Screen D14: displays the compressor discharge temperature and the corresponding status and envelope zone

Screen D15: compressor discharge overheating and related type of active control.

- SSH = Suction Super Heating
- DSH = Discharge Super Heating

Screen D19: Inverter/Motor Parameters

Screen D20: Inverter/Motor Parameters

Screen D21: Inverter/Motor Parameters

Screen D30, D31: screens related to the external battery fan. Rpm and instantaneous power absorbed are displayed.

Screen D32: shows performance.

- flow
- delta T (B7 - B4)
- electrical power consumption
- thermal power output
- COP

Screen D33: summary of unit parameters

14.13 ALARM LOG MENU

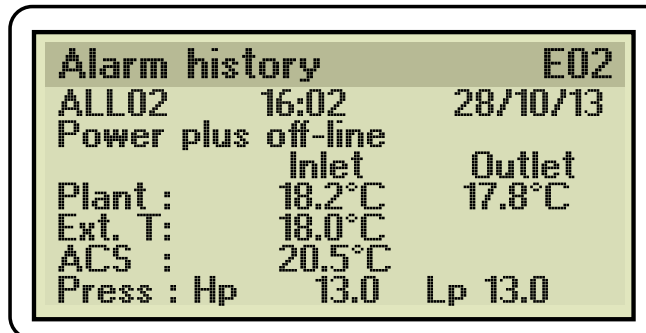

Alarm history		E02
ALL02	16:02	28/10/13
Power plus off-line		
	Inlet	Outlet
Plant :	18.2°C	17.8°C
Ext. T:	18.0°C	
ACS :	20.5°C	
Press : Hp	13.0	Lp 13.0

FIG. 77 (Alarm Log menu)

This menu allows you to view alarms due to possible activation of the protections.
Alarm list (s. par. 14.16).

14.14 CARD CHANGE MENU

The card change menu allows you to view the other heat pump(s) when they are connected via P-LAN and the settings of the electronic board/panel allow it.

14.15 SERVICE MENU

The Service menu has a submenu structured as follows:

- A. LANGUAGE CHANGE
- B. INFORMATION
- C. SERVICE INPUTS/OUTPUTS
- D. HOURS WORKED
- E. BMS CONFIG.
- F. SERVICE PARAM.
- G. MANUAL MANAGEMENT

A. LANGUAGE CHANGE

This menu allows you to change the language, if present.

Screen Ga01 Possible languages: Italian, English, German and French

B. INFORMATION *

This menu contains screens containing information relating to the software, the control board, the valves and the inverter, reserved for technical assistance.

C. SERVICE INPUTS/OUTPUTS

This menu contains the input and output masks, reserved for technical assistance.

Gc16: displays the opening of the injection valve in steps and as a percentage.

Gc17: inverter status.

Gc18: inverter status.

Gc22: inverter status.

Gc23: inverter status.

Gc24: digital inputs
Gc25: digital inputs
Gc26: digital inputs
Gc27: digital outputs
Gc29: digital outputs
Gc32: fan status

D. HOURS WORKED

This menu allows you to monitor working time

Screen Gd01: this screen displays the total operating hours of the heat pump.

Screen Gd02: This screen displays the number of defrosts performed by the machine during heat pump operation.

E . BMS CONFIGURATION

This menu allows you to set the communication protocol of the “BMS” port of the control electronics. This menu is password protected. Only authorised personnel can access it.

F . SERVICE PARAMETERS

This menu is password protected. Only authorised personnel can access it.

- a. hour meter settings
- b. probe calibration
- c. thermoregulation
- d. default user / password change

A. HOUR METER SETTINGS

Reserved for authorised personnel

B. PROBE CALIBRATION

Gfb01: calibration of probes B1 and B2

Gfb02: calibration of probes B3 and B4

Gfb03: calibration of probes B5 and B6

Gfb04: calibration of probes B7 and B8

The position of probe B8 can affect its operation. Therefore for the B8 probe only, it is possible to choose between the following options:

- on-board: the on-board probe is set.
- remote: the remote probe is set.

Gfb05: calibration of probes B9 and B10

Gfb06: calibration of probes B11 and B12

Gfb07: offset S1, S2

Gfb08: offset S3, S4

Gfb09: enables and sets calibration of probes B2 and B3

C. THERMOREGULATION

Screen Gfc01: sets the presence of a puffer and auxiliary integration.

- presence of puffer: (yes - no)
- system integration: (none - boiler)
- DHW integration: (none - boiler)

Screen Gfc02: configuration of integration request parameters.

Allows you to define the intervention thresholds for the auxiliary integration (boiler/electrical heating element) to the heating based on the demand (ability to reach the setpoint in a given time interval) and its proportional part.

The working condition at which the heat pump needs help from the integration (i.e. the “crisis” condition) is defined.

- **ON-Request:** represents the request generated by the PID of the water. Once this is reached, the integration is activated.
- **ON-Propor.:** represents the distance from the set, as a percentage, above which the auxiliary integration can be activated.

For example: the factory setting for proportional band percentage Hc06 is set to 10.

60% of 10 is 6°C. Represents the proportion that enables the integration of auxiliary heating.

The higher this value, the further the machine is from the set. If this value is low and the previous value was high, the boiler could start even when it not necessary, for example if the machine was close to the set (low proportional) for a long time (high integral thrust), without reaching it. In this case, the machine would be slightly undersized but would still be able to heat the water, without any need for the boiler to intervene.

The combination of the two previous parameters, therefore, identifies when the machine is really in a crisis and needs integration. When both conditions occur, the integration is activated.

- **OFF-Propor.:** the percentage of proportional band Hc06, which is set to 10 by default, below which the integration turns off.
- **OFF-Diff.:** Degrees that the integration must produce in addition to the Setpoint set on the heat pump.

Screen Gfc03: activation of integration in case of need (heat pump in “crisis”).

- **Setpoint att.:** external temperature value below which the boiler is enabled to start if the machine is considered to be in crisis (parameters in Gfc02)
- **Differential:** positive deltaT, that is, the integration remains enabled until the external temperature reaches a value equal to Setpoint+Differential.
- **Boiler activation delay:** once the previous conditions have been verified, the boiler activates if they remain in place for the set time.

Screen Gfc04: integration activation based on external temperature.

In this case, the integration is activated when the external air temperature drops below the set value. Once the auxiliary source is activated, it works together with the heat pump, unless its shutdown has been set. The integration remains active until the set water setpoint is reached, even if the air temperature rises above the set value.

- **Setpoint att.:** external temperature value that enables the heating integration function regardless of other factors
- **Differential:** positive deltaT, that is, the integration remains enabled until the external temperature reaches a value equal to Setpoint+Differential.
- **Shut down compressors:** allows the heat pump to be shut down below the temperature defined in Setpoint Att.: the supplementary system totally replaces the heat pump.

Screen Gfc05: DHW integration based on external temperature.

- **DHW Diff.on:** external temperature value beyond which the DHW integration device turns on. It remains on until it reaches the value set in DHW Diff. off.
- **DHW Diff.off:** temperature threshold below which the DHW integration device is switched off.
- **Delay ON:** delay in activating the integration once the above conditions have been met.

Screen Gfc06: climate curve setting.

- **Primary system temp. adjustment:** the choice is between **FIXED POINT** and **3-POINTS CURVE**:

FIXED POINT: the machine adjusts according to the set point that has been set, whatever the external air temperature.

3-POINTS CURVE: this is the setting we recommend. The three points for external temperature/set point temperature can be set directly. The logic is constructed as in the following figure:

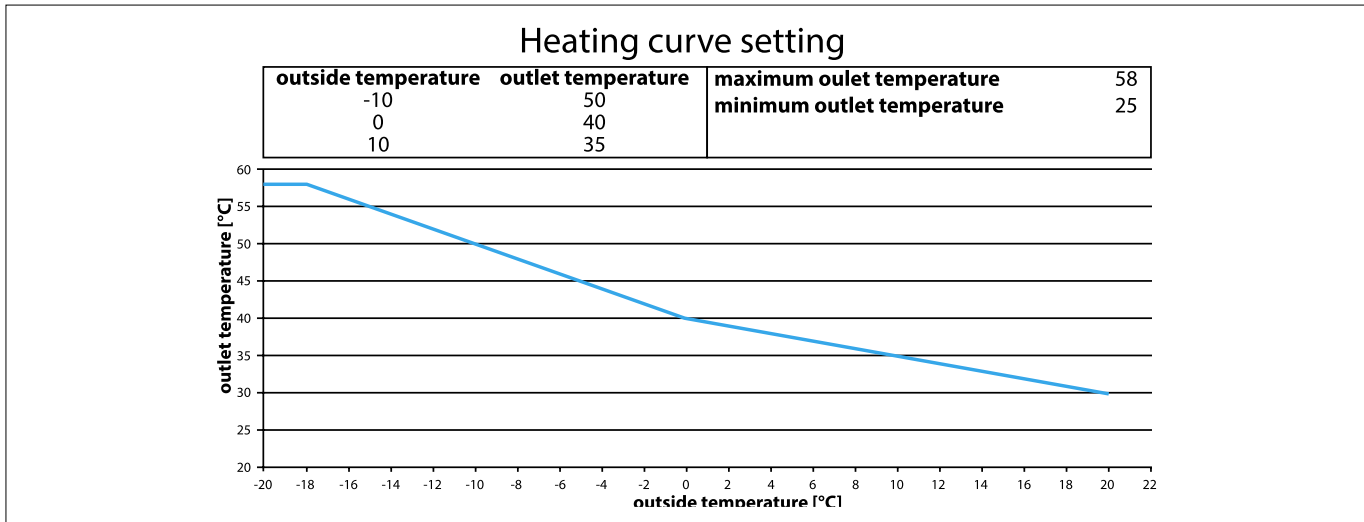

FIG. 78 (3-Points Curve graph)

The active Nominal Set is also displayed.

By varying the Nominal Set from the SETPOINT menu (B01), the entire climate curve will undergo a positive or negative shift depending on the Set. (For example, if the nominal set is changed from 35°C to 33°C, the entire curve will be lowered by 2°C in each working condition).

Screen Gfc07: reserved

Screen Gfc08: circulator management with puffer disabled.

- **Delay OFF:** when the compressor stops, the circulator operates for the number of seconds set
- **Start delay:** time in minutes from compressor shutdown to function start-up;
- **Pump ON time:** circulator operating time
- **Pump OFF time:** circulator stopped time

Screen Gfc15: antifreeze alarm reset.

- **Primary circuit anti-freeze alarm reset:** allows you to determine whether the reset is manual or automatic.
- **Manual:** (default) the machine restarts only if the user resets the alarm manually.
- **Auto:** the machine restarts automatically when the delivery temperature has risen to the value Set_antifreeze_alarm + Activation_Diff.

Screen Gfc16: circulator operating mode.

- **Activate primary circuit pump:** you can choose between “ON REQUEST” and “ON UNIT”.
- **On request:** the circulator starts only if requested by the heat pump (i.e. when it is required to start the compressors or to handle any antifreeze alarms).
- **On unit:** circulator starts when the unit is ON.
- **Pump for antifreeze:** enables activation of the pump (circulator) for the winter antifreeze function.

Screen Gfc17: Setpoint on the temperature of the system for activation of the antifreeze that activates the circulator.

Primary circuit antifreeze pump set: temperature setting that activates winter antifreeze protection. When the delivery temperature (probe B7) is below the value set here, the circulation pump is activated to maintain a continuous flow inside the hydraulic pipes.

- **Antifreeze pump activation diff.:** the pump, activated by the antifreeze protection, continues to run until the delivery temperature is Set+Diff.

Screen Gfc18: Setpoint on the outdoor temperature for activation of the antifreeze that activates the circulator.

- **Setpoint:** outdoor temperature value below which the winter antifreeze function is activated. This means it turns on the circulator for water recirculation in the pipes.
- **Diff.:** temperature differential added to the setpoint to determine the outdoor air temperature that inhibits the winter antifreeze function when activated.
- **Time ON and Time OFF** times for switching the heat pump on and off during the winter antifreeze protection function. Time ON and OFF are expressed in minutes

Note: the setpoints on these screens (17 and 18) depend on the type of installation. For example, with air probe B8 exposed to the sun, an incorrect value could be read, invalidating the function. If the probe is exposed to the sun, we recommend installing a remote probe and installing it in a shaded place.

Screen Gfc20: overheating reset setting.

- **Primary circuit overheating alarm reset:** allows you to determine whether the reset is manual or automatic.
- **Manual:** (default) the machine restarts only if the user resets the alarm manually.
- **Auto:** the machine restarts automatically when the delivery temperature drops to the value Overheat_alarm_set-Activation_Diff.

Screen Gfc21: selection for setting the mode (winter or summer) via the operator panel or via the external (digital) switch.

- **Summer/Winter select.** Season from: you can choose between “KEYBOARD” (operator panel) or “DIG.IN. 1” In this case, you must take into account that it is not enough to manage summer/winter switching but also the production of domestic hot water if the unit also has to produce DHW. For details, see the documentation relating to the no puffer function at the end of the manual.

Screen Gfc22:

- **Enable protection:** allows you to enable or disable the winter antifreeze protection function that activates the compressors when the plate heat exchanger has reached an excessively low temperature. If the previous parameter is active, the following parameters also become editable:
- **Unit ON:** delivery water temperature value (probe B7) that activates the function
- **Unit OFF:** delivery water temperature value (probe B7) that stops the protection function.

Screen Gfc23: enabling external signals

- **Enable alert signals on output NO7:** allows you to enable digital output NO7, to which a notification LED could be connected, for example, when the machine is in alarm status due to minor causes.

Screen Gfc25: defrost setting.

- **Fan Consumption:** fan consumption in W measured by the electronics and used to start the defrosting procedure.
- **Start delay:** delay from start-up of the compressor after which defrosting is allowed to start. To prevent defrosting from starting immediately after compressor start-up, where defrost start-up conditions could occur due to ignition dynamics.
- **Fan Delay:** pause time before starting defrosting
- **Defrost Delay with temperature differences:** Waiting time for activation of defrosting due to Delta T.

Screen Gfc27: defrost parameters.

- **En oil defrost:** variable that enables the return of the oil through the defrost cycle. If enabled and if the unit requires the return of the oil, the normal defrost procedure is activated with a maximum speed that can be set with the following parameter “Defrost Speed”.
- **Low speed defrost:** if the compressor had a speed less than Threshold when defrost was started, the compressor speed during defrost will be Defrost Speed.

Screen Gfc34: dripping parameters.

- **Dripping Mgmt.:** enables operation of the fan before inversion of the 4-way output of the defrosting cycle. By rotating at a high speed, the fan facilitates elimination of the water drops still present on the battery.
- **Fan Dripping Speed:** the speed at which the fan is forced in this specific phase of the defrost process.
- **Fan reverse Dir:** allows you to enable or disable reversal of fan rotation direction. If enabled, dripping is performed with counter-rotating fan.

Screen Gfc37: defrost parameters.

- **System integration during defrosting.:** Enables the system integration generator (boiler or electrical heating element).
- **End of defrost.:** Once max time is exceeded: it allows you to choose between LOG and LOG+ALARM, that is, to choose the recording/signalling mode for the event "defrosting is stopped because the maximum time has been exceeded".

Screen Gfc50: allows you to enable the condensate drain in fixed or intermittent mode according to the external temperature.

- **Cond. Drain element.:** enables activation of the condensate drain heating element.
- **ALWAYS ON (Set1):** in this condition, the heating element is always active below this parameter
- **Set:** temperature value at which the condensate drain heating element will remain active at all times.
- **Diff:** temperature differential. When the external temperature is equal to $Text = Set + Diff$, this function is exited
- **ON-OFF MODE (Set2):** in this condition, the heating element is activated below the set value, at time intervals as defined by the following parameters.
- **Set:** temperature value reached at which the function is activated.
- **Diff:** temperature differential. When the external temperature is equal to $Text = Set + Diff$, this function is exited
- **T.On:** heating element on time in minutes.
- **T.Off:** heating element off time in minutes.

Screen Gfc51: power consumption limitations.

- **En.Watt limit rps:** Enabling limitation of the maximum speed allowed for the compressor based on the actual consumption in Watts.
- **Thr.:** maximum threshold that can be reached by overall consumption (compressor, fan, auxiliaries, circulator, auxiliaries...)
- **Band:** Band within which the instantaneous consumption value can fluctuate, but always remaining below the set threshold
- **Fan:** Consumption value read from the fan. The reading is only possible thanks to the Modbus communication protocol (protocol with which it communicates) RS 485 (physical network consisting of a certain number of wires). It is set to one to read the actual consumption value
- **Pump:** Consumption value of the circulator. For now, this is a constant value and equal to maximum consumption.
- **Aux:** Auxiliaries consumption value. Set to 20 W constant.
- **Update time:** time interval after which the variable containing the maximum speed allowed to the compressor is updated, up or down, if all conditions allow it.
- **Update rps:** positive or negative increment of the variable that contains the maximum speed allowed for the compressor.

Operation:

- if Thr is < than the current unit consumption, it triggers the limitation of the maximum number of revolutions of the compressor, decreasing them by "Update rps" every "Update time"
- if current consumption is between (Thr-Band) and Thr, no corrective actions are applied
- if current consumption is < (Thr-Band), the compressor is free of constraints (the maximum allowed speed may increase)

Screen Gfc55: enables control of the circulator in PWM.

- **Enabling:** yes/no
- **Usage mode:**
- **Delta T mode (B7-B4):** tries to automatically maintain the delta set by the circulator by slowing down or accelerating.
- **RPS:** the circulator follows the compressor revolutions by following the curve that can be set below.
- **Setpoint:** the degrees to be maintained if the function is enabled in Delta T mode

Screen Gfc56: allows you to change the defrost activation threshold

- **Model:** fan model present in the heat pump.
- **Amp:** defrost parameterisation.

D. USER DEFAULT/PASSWORD CHANGE

Screen Gfd01: allows you to change the password to access the service menu.

- **Delete alarm log:** delete the entire alarm log.
- **Enter new password:** allows you to change the password to access the service menu

G . MANUAL MANAGEMENT

This menu is password protected. Only authorised personnel can access it.

Screen Gg01: Allows you to manually force (man) some digital outputs in order to check correct electrical connections. Refer to the manual supplied with the unit for any other digital outputs present

- **N04 primary pump:** allows you to activate the circulator.
- **N05:** allows the condensate drain heater to be activated.
- **N09 DHW 3-way valve:** three-way valve for DHW production, if present.

Screen Gg02: allows you to force the fan at the desired speed, selectable from Power Required.

- **Fan Speed:** activates manual fan speed management.
- **Required Power:** % active if manual management is enabled.

Screen Gg03: manual or automatic management of the expansion valve.

- **Enable manual valve position:** enables manual management.
- **Manual valve position:** if manual management is activated, it indicates the valve opening measured in steps.



⚠ WARNING

IF MANUAL VALVE MANAGEMENT IS ACTIVE, EXTREME CAUTION MUST BE EXERCISED TO AVOID BREAKAGE OF THE OF THE COMPRESSOR AND VOIDING OF THE WARRANTY

Screen Gg04: manual or automatic management of the injection valve.

- **Enable manual valve position:** enables manual management.
- **Manual valve position:** if manual management is activated, it indicates the valve opening measured in steps.

Screen Gg05: manual or automatic management of the heat pump.

- **CH/HP Request:** enables manual management of the compressor speed for the heating and cooling heat pump.
- **speed:** if manual management is activated, it indicates the speed of the compressor for the heat pump
- **DHW Request:** Enables manual compressor speed management for DHW production.
- **speed:** if manual management is activated, it indicates the compressor speed for DHW.

Screen Gg06: enables a defrost cycle.

- **Start defrost cycle:** starts a defrost cycle.

Screen Gg07: oil recovery management

- **Enable oil forcing:** enables forcing of the oil recovery cycle.
- **En. manual PWM:** to force the circulator speed.
- **PWM request:** sets the speed at which PWM is to be set while manual enabling is activated.

Screen Gg08: Integration management.

- **N06 Plant Integr.:** auxiliary heater outlet (e.g. boiler)
- **N08 DHW Integr.:** auxiliary heater output for DHW (e.g. electric boiler).

Screen Gg09: only in the AIR version. Internal fan management.

- **Fan speed:** activates manual fan speed management.
- **Required Power:** % active if manual management is enabled.

Screen Gg10: this screen allows you to manage the Screed Dry function.

- **Start cycle:** sets whether or not to activate the function The current water setpoint is shown at the side.
- **Elapsed time:** displays the time elapsed since the function was activated.
- **Start temperature:** the starting temperature of the function.
- **Target temperature:** the target temperature of the function.
- **Raise hours:** the number of hours it takes to reach the target temperature starting from the starting temperature.
- **Stabilise hours:** the number of hours for which the temperature must remain stable at the target temperature.
- **Cool down:** the number of hours it takes to return to the start temperature.

Screen Gg11: this screen allows you to ignore the compressor oil temperature control.

Screen Gg12 initialisation: this screen is used to initialize the heat pump. Initialisation resets all data previously present in the pump.

14.16 ALARMS

Code alarm	Message	Reset	Delay	Relay	Action
ALA01	Probe B1 broken or disconnected	Automatic	60 s	Yes	Stops the machine
ALA02	Probe B2 broken or disconnected	Automatic	60 s	Yes	If there is a modulating geothermal pump, it is adjusted to maximum speed
ALA03	Probe B3 broken or disconnected	Automatic	60 s	Yes	Stops adjustment of the DHW circuit
ALA04	Probe B4 broken or disconnected	Automatic	60 s	Yes	Stops the machine
ALA05	Probe B5 broken or disconnected	Automatic	60 s	Yes	Stops the machine
ALA06	Probe B6 broken or disconnected	Automatic	60 s	Yes	Stops the machine
ALA07	Probe B7 broken or disconnected	Automatic	60 s	Yes	Stops the machine
ALA08	Probe B8 broken or disconnected	Automatic	60 s	Yes	Stops the machine
ALA09	Probe B9 broken or disconnected	Automatic	60 s	Yes	Stops the machine
ALA10	Probe B10 broken or disconnected	Automatic	60 s	Yes	Stops the machine
ALA11	Probe B11 broken or disconnected	Automatic	60 s	Yes	Stops the machine
ALA12	Probe B12 broken or disconnected	Automatic	60 s	Yes	Stops the machine

continued

Code alarm	Message	Reset	Delay	Relay	Action
ALB01	Position: DI3 High pressure	Manual	Immediate	Yes	Stops the machine
ALB02	Compressor 1 high pressure from transducer	Manual	Immediate	Yes	Stops the machine
ALB03	Low pressure of compressor (s) from transducer	Automatic (screen Hc05)	At start-up: 40 s (screen Hc03) at speed: 10 s (screen Hc04)	Yes	Stops the machine
ALC01	Position: DI2 Compressor 1 thermal protection or inverter alarm	Manual	Immediate	Yes	If 1 compressor enabled: stops the machine If 2 compressors enabled: stops comp. 1 (if comp. 2 available)
ALC02	Position: DI9 Compressor 2 thermal protection	Manual	Immediate	Yes	Stops comp. 2 (if comp. 1 available)
ALC03	Envelope alarm: 0: Max. compr. ratio 1: Max. discharge press. 2: Current limit 3: Max. intake press. 4: Min. compr. ratio 5: Min. pressure diff. 6: Min. discharge press. 7: Min. intake. press. Compressor off due to out of envelope operation (only with Siam compressor)	Manual	60 s (screen H1b14)	Yes	Stops the compressor.
ALC04	Compressor start-up failure alarms (only with Siam compressor)	After 5 times in one hour, it becomes manual	60 s (screen H1b11)	Yes	Stops the compressor.
ALC05	Max. discharge time (only with Siam compressor)	After 3 times in one hour, it becomes manual	Immediate	Yes	Stops the compressor.
ALC06	Pressure delta < minimum required for compressor oil return (only with Siam compressor)	Automatic	120 s (screen H1b12)	Yes	Stops the compressor.
ALP03	Position: DI10 Water flow switch, primary circuit	After 5 times in one hour, it becomes manual	At start-up: 15s (screen Hc12) at speed: 5s (screen Hc13)	Yes	Stop the machine when the maximum time is reached
ALR01	Position: DI7 Boiler/ System integration heating element alarm	Automatic	Immediate	Can be enabled (screen Gfc02)	Stops integration boiler/heating element operation, primary circuit
ALU02	Primary heat exchanger antifreeze	Manual (screen Gfc32)	Immediate	Yes	Stops the machine
ALU03	System heat exchanger overheating	Manual	Immediate	Yes	Stops the machine

continued

Code alarm	Message	Reset	Delay	Relay	Action
ALW01	DHW high temperature threshold reached	Automatic	60 s	Can be enabled (screen Gfc01)	Signal only
ALW03	Max. time for end of defrosting exceeded	Automatic	Immediate	Yes	Signal only
ALD01	EEPROM alarm	Manual	Immediate	Yes	Stops the machine
ALD02	EVD EVO probe broken or disconnected	Automatic	Immediate	Yes	Stops the machine
ALD03	EEV motor error	Manual	Immediate	Yes	Stops the machine
ALD04	Low overheating (LowSH)	Manual	Immediate	Yes	Stops the machine
ALD05	Low intake temperature	Manual	Immediate	Yes	Stops the machine
ALD06	Low evaporation temperature (LOP)	Manual	Immediate	Yes	Stops the machine
ALD07	High evaporation temperature (MOP)	Manual	Immediate	Yes	Stops the machine
ALD08	High condensing temperature (HiTcond)	Manual	Immediate	Yes	Stops the machine
ALD09	Driver offline	Manual	Immediate	Yes	Stops the machine
ALL01	Power+ device 1 offline	Automatic	30 s	Yes	Stops the machine
ALL02	Power+ 1 alarms 0: No error 1: Overcurrent 2: Motor overload 3: Overvoltage 4: Undervoltage 5: Overtemperature 6: Undertemperature 7: HW overcurrent 8: Motor overtemperature 9: Reserved 10: CPU error 11: Default parameter 12: DC bus ripple 13: Ser. Com. timeout 14: Thermistor error 15: Autotuning error 16: Drive disabled 17: Motor phase missing 18: Fan faulty 19: Engine stalled	Manual	Immediate	Yes	Stops the machine

TAB. 52 (Alarms)

The letter before the numeric digit has the following meaning:

Letter	Description	Letter	Description
A	"AIN" uPC Physical Probe failure	P	"Pumps" Pump flow switches, pump thermal protection
B	"Boh" Circuit Blocking Alarms, High-Low Pressure	Q	"Quality" HACCP, Consumption
C	"Compressor" Thermal protections, envelope	R	"Remote" Miscellaneous alarms from digital inputs
D	"Driver" Electronic valve	S	"Serial probe" Serial probes
E	"Expansion" uPCe alarms	T	"Timing" Maintenance warning
F	"Fan" fans	U	"Unit" Alarms that block the unit
G	"Generic" generic alarms, Clock broken, HW, Memory	V	"VFD" Field inverter alarms
H	"Humidifier" humidifier	W	"Warning" generic warnings
I	"Fancoil" alarms from a hydronic network	X	Defrosting
M	"MP-BUS" / Belimo	Y	Climate
O	"Offline" Offline supervisor, offline P-LAN		

TAB. 53 (Meaning of the letter before the numeric digit)

14.17 STARTING THE MACHINE



Proceed as follows from the HCC remote control to start the machine:

1) Touch the icon (FIG. 70 - Ref. 4) to turn the machine on.

- With the **green** icon, the machine is on
- With the **grey** icon, the machine is switched off but with voltage inside the panels
- If the external colour icon does not match the internal colour, this means that the machine is moving from one state to another
- When the colours match, it means the machine will have assumed the new state
- If the external colour is not visible, the machine has a fault



WINTER FAULT

If the “Flame” (FIG. 70 - Ref. 6) icon is on, it means that the machine will produce hot water.

SUMMER MODE

If the “Snow” (FIG. 70 - Ref. 7) icon is on, it means that the machine will produce cold water.

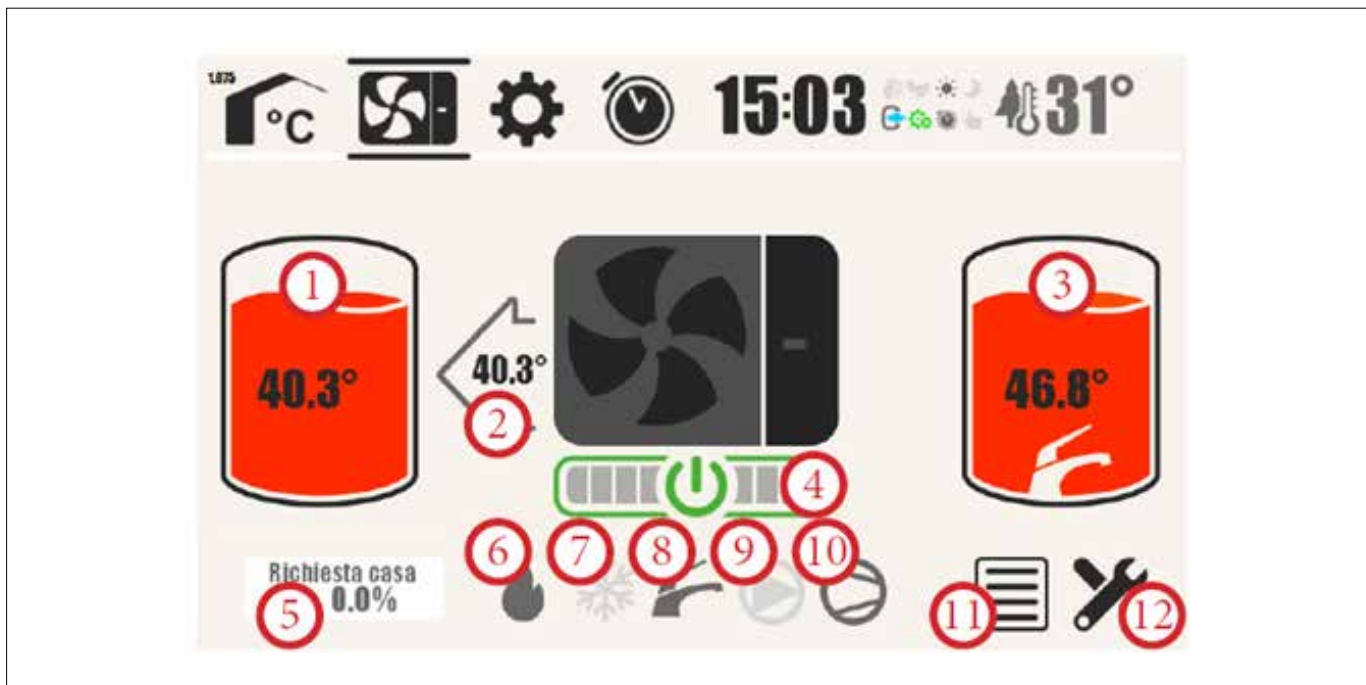

FIG. 79 (HCC remote control ON - OFF button)

14.18 HEAT PUMP SETTINGS



⚠ WARNING

IT IS MANDATORY TO REFER TO THE ATTACHED TECHNICAL DOCUMENTATION FOR USE AND OPERATION OF THE HCC REMOTE CONTROL.

FIG. 71 - Ref. 8: The heating setpoint for the profile currently in progress

Touching the “flame” icon (FIG. 71 - Ref. 8) allows you to change the work mode. Touching the setpoint allows you to change the setpoint.

FIG. 71 - Ref. 9: The domestic hot water setpoint for the profile currently in progress.

Touching the tap icon (FIG. 71 - Ref. 9) allows you to change the work mode. Touching the setpoint allows you to change the setpoint.

FIG. 71 - Ref. 10: The cooling setpoint for the profile currently in progress.

Touching the snowflake icon (FIG. 71 - Ref. 10) allows you to change the work mode. Touching the setpoint allows you to change the setpoint.

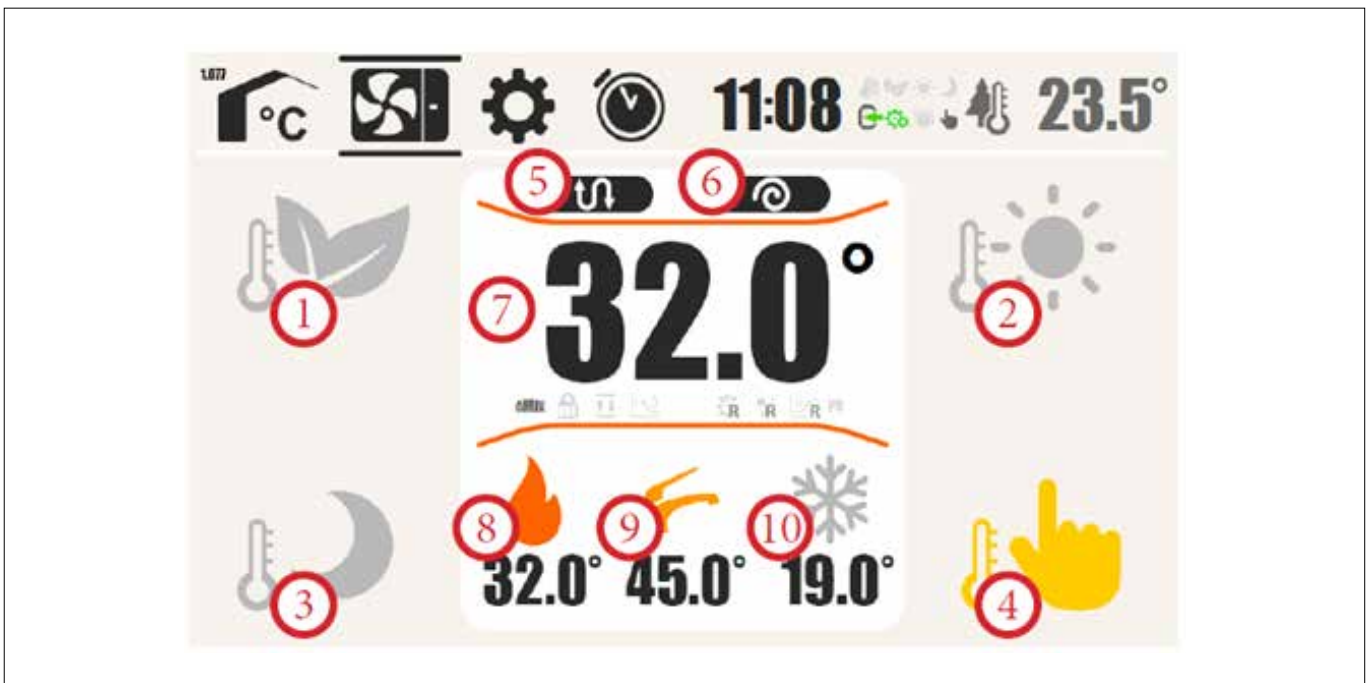

FIG. 80 (HCC remote control set temperatures)

14.19 MACHINE SHUTDOWN



To stop the machine from the HCC remote control, proceed as follows:

- 1) Touch the icon (FIG. 70 - Ref. 4) to shut down the machine.
- 2) Turn the main power switch (supplied by the customer) to the “O-OFF” position



14.20 OPERATING METHOD TO BE FOLLOWED IN CASE OF INJURIES OR BREAKDOWNS

Proceed as follows in case of injuries or breakdowns:

- 1) Turn the main power switch to (supplied by the Purchaser) to the “**O-OFF**” position
- 2) If present, comply with the “**Company procedure in case of injuries**”, otherwise proceed to the following points
- 3) If present, promptly notify the **Supervisor** and the **First Aid Manager (s. par. 2.3)**, otherwise proceed with the following points
- 4) If possible, move the injured operator clear of the machine and place him/her in safe conditions, remaining alongside the person and providing assistance until help arrives
- 5) If the injured operator is in an obviously life-threatening condition, call **112 (Common European emergency telephone number)** immediately to report the emergency and request assistance.
- 6) Wait for help to arrive



⚠ WARNING

IF THE INJURED OPERATOR IS IN AN OBVIOUSLY LIFE-THREATENING CONDITION, CALL **112 (COMMON EUROPEAN EMERGENCY TELEPHONE NUMBER)** IMMEDIATELY TO REPORT THE EMERGENCY AND REQUEST ASSISTANCE.

14.21 OPERATING METHOD TO BE FOLLOWED IN CASE OF FIRE

Proceed as follows in case of fire, with presence of smoke, heat, flames, etc.:

- 1) Immediately set the machine to “**safety status**” (s. par. 5.1)
- 2) If present, comply with the “**Company procedure for action in case of fire**”, otherwise proceed with the next points.
- 3) If present, promptly notify the **Supervisor** and the **Fire Safety Manager (s. par. 2.3)**, otherwise proceed with the following points
- 4) Sound the alarm immediately and evacuate the occupants, directing them to the official muster point
- 5) Only if authorised and in safe conditions, fight the fire with suitable equipment (blanket, extinguisher, water, etc.) to prevent it from spreading.
- 6) Before the fire spreads, call **112 (Common European Emergency Telephone Number)** to report the emergency and request the intervention of the **Fire Service**.
- 7) Wait for the **Fire Service** to arrive.



⚠ WARNING

IF THERE IS A FIRE OUTBREAK YOU MUST SOUND THE ALARM TO EVACUATE THE OCCUPANTS TO THE OFFICIAL MUSTER POINT.



⚠ DANGER

DO NOT USE WATER TO EXTINGUISH FIRES ON LIVE ELECTRICAL EQUIPMENT.



⚠ DANGER

USE ONLY CERTIFIED FIRE-FIGHTING EQUIPMENT SUITABLE FOR THE TYPE OF FIRE (EXTINGUISHERS, BLANKETS, ETC.).



⚠ WARNING

BEFORE THE FIRE SPREADS, CALL **112 (COMMON EUROPEAN EMERGENCY TELEPHONE NUMBER)** IMMEDIATELY TO REPORT THE EMERGENCY AND REQUEST THE INTERVENTION OF THE FIRE SERVICE.

15 TROUBLESHOOTING



⚠ DANGER

IT IS PROHIBITED TO USE THE MACHINE IN THE PRESENCE OF ANY TYPE OF FAULT.



⚠ DANGER

IF THE MAINTENANCE TECHNICIANS ARE UNABLE TO SOLVE THE FAULT THE ASSISTANCE OF THE MANUFACTURER'S TECHNICIAN MUST BE REQUESTED.



⚠ DANGER

ALL MAINTENANCE OPERATIONS ON THE MACHINE MUST BE CARRIED OUT WITH THE MACHINE IN "SAFETY STATUS" (S. PAR. 5.1).

Fault (Alarm code)	Cause	Solution
ALB01	High condensing pressure: most of the time, this alarm is caused by the water produced both in heating and in DHW being set too high. Other very frequent causes for this are: incorrect positioning of the adjustment probes (B2 and B3) with respect to the supply of the unit and insufficient flow of water to the plate condenser.	1) position probes B2 and/or B3 at the same height with respect to the machine supply accumulation inlet.
ALB02		
ALB03	Low pressure from the transducer can be linked to the internal dynamics of the machine. But it can also be a symptom of a transducer malfunction or a refrigerant leak.	If the alarm is frequent - 2/3 times consecutively within 4-6 hours - inspect the unit with a leak detector and contact the service department
ALC03	Envelope alarm, the compressor is outside its operating range. In this case, there are multiple that cannot be listed.	It is recommended first of all to evaluate the use of the unit, which may be inconsistent with the working range of the unit, for example, DHW operation with external temperatures that are too high. Please refer to the "permitted operating area" section of this manual.
ALC04	The compressor fails to create a minimum pressure delta in a certain time interval. The cause may be the inertia of the system and the proximity between air and water temperatures	If it occurs occasionally, it is simply a warning of a non-serious nature that allows the unit to continue operating.
ALP03	Lack of flow in the hydraulic circuit, caused by air in the system, solid sediment or excessive pressure drops	Bleed the system of all the air present. Regular cleaning of the system. Avoid excessive pressure drops in the hydraulic circuit. In particular, avoid bottlenecks in the system.
ALW03	Caused by drafts cooling the evaporator during the defrosting procedure	Try positioning the machine differently or obstruct the wind directed towards the unit.
ALD04	Alarm due to the internal dynamics of the machine	Contact the service department

continued

Fault (Alarm code)	Cause	Solution
ALD06	Alarm due to the internal dynamics of the machine	Inspect the unit with a leak detector and contact the service department
ALD07	Alarm due to the internal dynamics of the machine	Contact the service department
ALL01	Lack of communication between the inverter and the electronic board caused by slight voltage and current surges or by electromagnetic fields disturbing the network.	Check the meter that powers the machine to avoid overloading it. Check the domestic line. Avoid electromagnetic fields in the vicinity
ALL02	Lack of communication between the inverter and the electronic board caused by large voltage and current surges or by electromagnetic fields disturbing the network.	Check the meter that powers the machine to avoid overloading it. Check the domestic line. Avoid electromagnetic fields in the vicinity. Then contact the service department

TAB. 54 (Troubleshooting)

15.1 WARNINGS

Warning	Cause
Heat Transfer Limited	It occurs when the difference between the value of B7 and B2 in the case of system operation, or the difference between B7 and B3 in the case of DHW operation, is excessive.
Limitation of power due to temperature	It is activated if the pump is producing water at less than 6°C or more than 58°C. The compressor is brought to a minimum speed to avoid generating an error.
Irregular water flow	There has been a flow switch problem at least once since the pump was powered. After 5 of these warnings, the next notification will be a flow switch error.

TAB. 55 (Warnings)

16 MAINTENANCE

16.1 GENERAL NOTICES



⚠ DANGER

ALL MAINTENANCE OPERATIONS ON THE MACHINE MUST BE CARRIED OUT WITH THE MACHINE IN "SAFETY STATUS" (S. PAR. 5.1).



⚠ DANGER

AUTHORISED OPERATORS MUST NOT LEAVE THE MACHINE UNATTENDED DURING MAINTENANCE OPERATIONS WITHOUT TAKING THE NECESSARY PRECAUTIONS TO PREVENT ACCESS BY UNAUTHORISED PERSONS.



⚠ WARNING

AUTHORISED OPERATORS MUST CARRY OUT ONLY THE REQUIRED MAINTENANCE WORK IN ACCORDANCE WITH THEIR SPECIFIC COMPETENCES AND ON RECEIVING THE SUPERVISOR'S CONSENT.

IT IS MANDATORY TO WAIT FOR THE TIME NECESSARY TO REACH ROOM TEMPERATURE.



⚠ WARNING	
IT IS PROHIBITED TO USE PRODUCTS WITH CHARACTERISTICS DIFFERENT FROM THOSE SPECIFIED BY THE MANUFACTURER (S. PAR. 5.15).	
THE AUTHORISED OPERATORS MUST READ THE SAFETY DATASHEETS SUPPLIED BY THE PRODUCERS OF SUCH PRODUCTS AND ENSURE THEY HAVE A FULL UNDERSTANDING OF THEIR CONTENTS.	

16.2 ROUTINE MAINTENANCE

Routine maintenance consists of the set of jobs aimed at keeping the machine in good working order (adjustments, visual inspections, levels, etc.); these tasks are carried out by the machine operator at the prescribed frequencies.

16.2.1 ROUTINE MAINTENANCE TABLE

Operator	Frequency	Point of service	Job type
	Every 12 months	Machine	Internal cleaning (evaporator fins, blades, grille) (SM-01)
			Check for refrigerant gas leaks with suitable instrumentation
		Condensate drain	Check for drain clogging and cleanness of the condensate collection tank
		Magnetic dirt separator	Visual inspection and discharge of impurities (SM-02)
		Electrical connections	Check status of connections
	Pipes	Check corrosion and leakage status	
	Every 3 years	Anti-vibration feet (if present)	Check for wear and replace if necessary

TAB. 56 (Routine maintenance table)

16.3 MAINTENANCE SHEETS

The following pages contain the:

- 1) **“Maintenance Sheets” (SM)** with a description of the point of service and instructions concerning the job.
- 2) **“Job Sheets” (SR)** to be filled in by the authorised operator who carried out the service.

	Maintenance Sheet	Point of service	Machine
	SM-01	Job type	Internal cleaning (evaporator fins, blades, grille)

FREQUENCY: Every 12 months



- 1) Set the machine to “**safety status**” (s. par. 5.1)
- 2) Use suitable tools to undo the screws and remove the top panel
- 3) Clean with an air jet in a direction parallel to that of the evaporator fins, blades and grille. Remove any internal deposits
- 4) Clean the front surface.
- 5) Position the top panel and tighten the screws
- 6) Make a note of the operation on job sheet **SR-01**

⚠ WARNING



IT IS FORBIDDEN TO TOUCH THE EVAPORATOR FINS, WHICH CAN CAUSE CUTS.

IT IS FORBIDDEN TO BEND THE FINS OF THE EVAPORATOR AS THIS REDUCES THE PERFORMANCE OF THE MACHINE. IF THE FINS ARE BENT, CONTACT THE MANUFACTURER OR THE AUTHORISED SERVICE CENTRE.

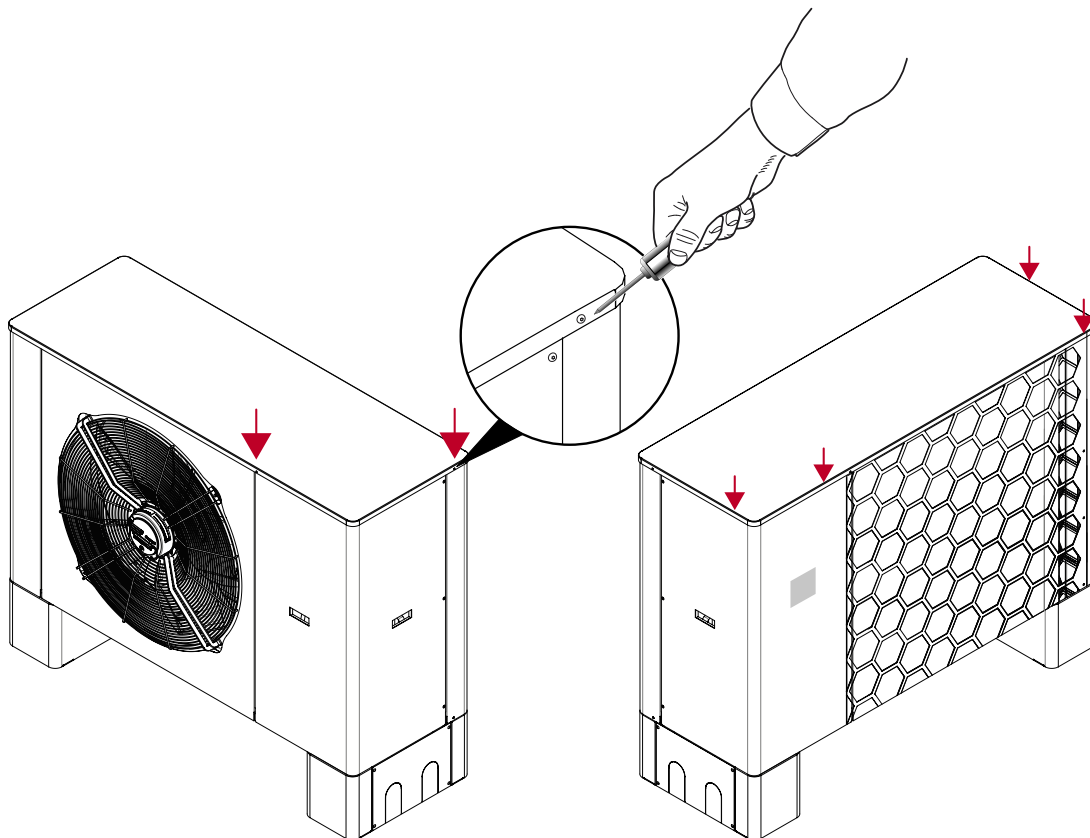

	Maintenance Sheet	Point of service	Magnetic dirt separator
	SM-02	Job type	Visual inspection and discharge of impurities

FREQUENCY: Every 12 months



- 1) Set the machine to “**safety status**” (s. par. 5.1)
- 2) Close the shut-off valves of the system and bring to atmospheric pressure
- 3) Remove the impurity collector and clean it
- 4) Refit the impurity collector.
- 5) Make a note of the operation on job sheet **SR-02**

	Job Sheet	Point of service	Magnetic dirt separator	
	SR-02	Job type	Check Cleaning	
Date	Time	Notes		Signature
...../...../.....	:	<input type="checkbox"/> Check	
		<input type="checkbox"/> Cleaning	
...../...../.....	:	<input type="checkbox"/> Check	
		<input type="checkbox"/> Cleaning	
...../...../.....	:	<input type="checkbox"/> Check	
		<input type="checkbox"/> Cleaning	
...../...../.....	:	<input type="checkbox"/> Check	
		<input type="checkbox"/> Cleaning	
...../...../.....	:	<input type="checkbox"/> Check	
		<input type="checkbox"/> Cleaning	
...../...../.....	:	<input type="checkbox"/> Check	
		<input type="checkbox"/> Cleaning	
...../...../.....	:	<input type="checkbox"/> Check	
		<input type="checkbox"/> Cleaning	
...../...../.....	:	<input type="checkbox"/> Check	
		<input type="checkbox"/> Cleaning	
...../...../.....	:	<input type="checkbox"/> Check	
		<input type="checkbox"/> Cleaning	
...../...../.....	:	<input type="checkbox"/> Check	
		<input type="checkbox"/> Cleaning	
...../...../.....	:	<input type="checkbox"/> Check	
		<input type="checkbox"/> Cleaning	
...../...../.....	:	<input type="checkbox"/> Check	
		<input type="checkbox"/> Cleaning	

Maintenance jobs table with signature of authorised operator. Make photocopies for future requirements.

16.4 PERIODIC CHECK OF EFFICIENCY OF GUARDS AND PROTECTIVE DEVICES



DANGER



IT IS PROHIBITED TO TAMPER WITH AND/OR REMOVE ANY GUARDS OR PROTECTIVE SYSTEMS.
IT IS PROHIBITED TO REPLACE THE MACHINE GUARDS AND PROTECTIVE DEVICES USING PARTS THAT DO NOT COMPLY WITH THE SPECIFICATIONS OF THE RESPECTIVE MANUFACTURERS.

WARNING



IT IS MANDATORY TO KEEP A CONSTANT CHECK ON THE PROPER OPERATION OF ALL GUARDS AND PROTECTIVE DEVICES.
IT IS MANDATORY TO REPLACE ANY INEFFECTIVE OR DAMAGED GUARDS AND PROTECTIVE DEVICES IMMEDIATELY.

DANGER



ALL OPERATIONS AIMED AT CHECKING THE INTEGRITY AND EFFICIENCY OF THE GUARDS AND PROTECTIVE DEVICES MUST BE PERFORMED BEFORE EACH START-UP AND WITH THE MACHINE IN "SAFETY STATUS" (S. PAR. 5.1).

DANGER



DURING THE CHECKING OPERATIONS IT IS PROHIBITED TO LEAVE THE MACHINE UNATTENDED AND WITHOUT TAKING THE NECESSARY PRECAUTIONS TO PREVENT ACCESS BY UNAUTHORISED PERSONS.

WARNING



ANY REPLACEMENTS OF GUARDS AND PROTECTIVE DEVICES MUST BE PERFORMED EXCLUSIVELY BY A

MAINTENANCE TECHNICIAN



OR BY ONE OF THE MANUFACTURER'S TECHNICIANS



INFORMATION



THE SPARE PART SPECIFICATIONS AND METHODS OF REPLACEMENT ARE SHOWN IN **CHAP. 18**.

16.5 UNSCHEDULED MAINTENANCE



This is the set of activities performed in order to maintain the use and operating conditions of the machine by means of various types of actions (adjustments, replacements, etc.) to be performed exclusively by a qualified technician.



⚠ WARNING

UNSCHEDULED MAINTENANCE OPERATIONS CAN BE CARRIED OUT EXCLUSIVELY BY A QUALIFIED TECHNICIAN PROVIDED BY THE MANUFACTURER AND/OR BY THE SERVICE CENTRE.

16.6 SERVICE INSTRUCTIONS

Personnel working on systems with flammable gases (Class A3) may be subject to occupational hazards.

Comply with applicable regulations and national laws.

Repair and maintenance activities must be carried out by specialised technicians, i.e. experienced and qualified installers and refrigeration technicians who:

- **Have taken a training course at Templari S.p.A.**
- **Are authorised by Templari S.p.A.**
- **Have achieved the qualification for flammable refrigerant fluids according to UNI EN 378-4 or IEC 60335-2-40 (Annex HH)**



⚠ WARNING

IT IS MANDATORY TO USE COMPLIANT DEVICES AND MATERIALS FOR APPLICATIONS IN FLAMMABLE ATMOSPHERES.

MAKE SURE TO CARRY OUT SERVICE OPERATIONS IN OPEN AND VENTILATED PLACES.

USE GAS CONCENTRATION DETECTION TOOLS.

MAKE SURE YOU HAVE A FIRE EXTINGUISHER (DUST OR CO₂).



⚠ WARNING

BEFORE THE GAS RECOVERY PHASE, MAKE SURE THAT THE TWO ELECTRONIC VALVES ARE OPEN (USING THE APPROPRIATE MAGNETIC KEYS, TURN THEM CLOCKWISE TO OPEN THE VALVE).



⚠ WARNING

CARRY OUT GAS RECOVERY WITH A PUMP SUITABLE FOR USE IN FLAMMABLE ATMOSPHERES;

AFTER THE GAS RECOVERY PHASE, FLUSH WITH NITROGEN (P <5 bar FOR THE TIME REQUIRED);

REPEAT THE FLUSHING SEVERAL TIMES IF NECESSARY.



⚠ WARNING

SOLDERING OR DESOLDERING OPERATIONS MUST ALWAYS BE CARRIED OUT WITH NITROGEN FLUSHING.



⚠ WARNING

DO NOT USE TORCHES AND OPEN FLAMES TO DESOLDER THE COMPONENTS OF THE REFRIGERANT CIRCUIT. WHERE POSSIBLE, USE PIPE CUTTER TOOLS.

In the case of compressor replacement, download instructions from the download section of the www.templari.com website.

17 INSTRUCTIONS FOR DISABLING AND DISPOSAL



⚠ WARNING

IT IS PROHIBITED TO RELEASE RESIDUAL LIQUIDS AND LUBRICANTS INTO THE ENVIRONMENT.

⚠ WARNING

DISPOSE OF PRODUCTS CLASSIFIED AS POLLUTANT AND HAZARDOUS EXCLUSIVELY BY MEANS OF AUTHORISED DISPOSAL FIRMS SPECIALISED IN THE VARIOUS PRODUCTS INVOLVED.

SORT THE MACHINE PARTS IN ACCORDANCE WITH THEIR CONSTRUCTION MATERIALS (PLASTIC, FERROUS METAL, ETC.).

YOU MUST COMPLY WITH THE PRESCRIPTIONS OF STATUTORY LEGISLATION WHEN SCRAPPING THE MACHINE.

⚠ CAUTION

ALL MACHINE COMPONENTS MUST BE IDENTIFIED IN ACCORDANCE WITH THE EUROPEAN WASTE CATALOGUE (EWC) CODES AND DISPOSED OF BY CONSIGNING THEM TO AUTHORISED AND SPECIALISED FIRMS IN STRICT COMPLIANCE WITH STATUTORY LEGISLATION IN FORCE IN THE COUNTRY IN WHICH THE MACHINE IS TO BE SCRAPPED.

⚠ CAUTION

WASTE ELECTRICAL AND ELECTRONIC EQUIPMENT (WEEE) MUST BE DISPOSED OF IN STRICT COMPLIANCE WITH STATUTORY LEGISLATION IN FORCE IN THE COUNTRY IN WHICH THE MACHINE IS TO BE SCRAPPED.



18 SPARE PARTS

18.1 ORDERING PROCEDURE



⚠ CAUTION

GENUINE ORIGINAL ACCESSORIES AND SPARE PARTS FOR ANY REPLACEMENTS REQUIRED MUST BE ORDERED FROM THE MANUFACTURER OR THE RESPECTIVE PRODUCERS.



INFORMATION

THE GENERAL TERMS OF SALE MUST BE AGREED WITH THE MANUFACTURER.

19 ANNEXES

19.1 INSTRUCTIONS FOR HANDLING THE PACK



TEMPLARI
LA POMPA DI CALORE

TEMPLARI SPA
Via C. Battisti, 169 - 35031 Abano Terme (PD) Italy
Tel. +39 049 5225929
mailinfo@templari.com - www.templari.com









Cod. CM23026
Rev.00-IT
Em.21.07.23



Translation of the original packing instructions

© TEMPLARI SPA

INSTRUCTIONS FOR MOVING PACKING











⚠ DANGER



BEFORE MOVING THE PACKING, THE AUTHORIZED OPERATORS MUST READ AND BE SURE OF HAVING UNDERSTOOD IN FULL THESE INSTRUCTIONS. IT IS COMPULSORY TO ENSURE THAT THERE ARE NO PERSONS, ANIMALS AND/R THINGS IN THE RADIUS OF ACTION OF THE LIFT TRUCK, CRANE OR OVERHEAD CRANE. ALL THE OPERATIONS (LIFTING/LOWERING AND MOVING) MUST BE PERFORMED WITH THE MAXIMUM CAUTION, AVOIDING SUDDEN MANOEUVRES. DO NOT TILT THE MACHINE MORE THAN 45°.

⚠ WARNING



ALL THE OPERATIONS MUST BE CARRIED OUT BY AN OPERATOR FOR MOVEMENT: THIS IS A PROFESSIONALLY TRAINED OPERATOR WHO, IN THE RESPECT OF THE LEGISLATION IN FORCE IN THE COUNTRY OF USE, IS QUALIFIED TO DRIVE LIFT TRUCKS, OPERATE CRANES OR OVERHEAD CRANES, TO SAFELY TRANSPORT, MOVE AND UNPACK THE MACHINE AND/OR PARTS OF IT, USING HAND SIGNALS SHOWN IN EUROPEAN DIRECTIVE 92/58/EEC.

	LIFT TRUCK	CRANE OR OVERHEAD CRANE
1	CHECK THAT THE PACKING IS FREE FROM IMPEDIMENTS.	
2	INSERT THE FORKS OF THE LIFT TRUCK UNDER THE PACKING AND ENSURE THAT THEY COME OUT FROM THE OTHER SIDE.	HARNESS THE PACKING WITH LIFTING ACCESSORIES (ROPES, CABLES, SLINGS, HOOKS, SNAP HOOKS) SUITABLE FOR THE PURPOSE AND THE LOAD AND IN CONFORMITY WITH THE REGULATIONS CURRENTLY IN FORCE.
3	RAISE THE PACKING SUFFICIENTLY FROM THE GROUND WITH CAUTION AND TILT IT SLIGHTLY BACKWARDS.	
3		RAISE THE PACKING SUFFICIENTLY FROM THE GROUND WITH CAUTION.
4	MOVE THE PACKING WITH CAUTION.	
5	LOWER THE PACKING UNTIL IT RESTS COMPLETELY ON A FLAT, LEVEL AND STABLE SURFACE.	
6	SLIDE OUT THE FORKS OF THE LIFT TRUCK.	6 REMOVE THE LIFTING ACCESSORIES.

⚠ WARNING



TO MOVE THE MACHINE, THE PROCEDURES IN THE INSTRUCTION MANUAL MUST BE RESPECTED.









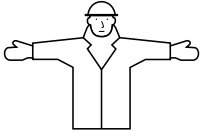
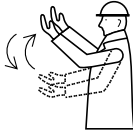

⚠ WARNING

THE MANUFACTURER DECLINES ALL LIABILITY FOR DAMAGE TO PERSONS, ANIMALS AND/OR THINGS CAUSED BY FAILURE TO OBSERVE THE INSTRUCTIONS SHOWN ON THIS SHEET AND IN THE INSTRUCTION MANUAL.

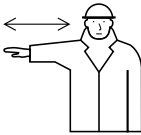
FIG. 81 (Instructions for handling the pack)

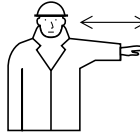
19.2 HAND SIGNALS (DIRECTIVE 92/58/EEC)



A. GENERAL SIGNALS		C. HORIZONTAL MOVEMENTS	
	<ul style="list-style-type: none"> • START • CAUTION • START OF COMMAND BOTH ARMS ARE EXTENDED HORIZONTALLY WITH THE PALMS FACING FORWARD.		<ul style="list-style-type: none"> • MOVE FORWARDS BOTH ARMS ARE BENT WITH THE PALMS FACING UPWARD; THE FOREARMS MAKE SLOW MOVEMENTS TOWARDS THE BODY.
	<ul style="list-style-type: none"> • STOP • INTERRUPTION • END OF MOVEMENT THE RIGHT ARM POINTS UPWARD WITH THE PALM FACING FORWARDS.		<ul style="list-style-type: none"> • MOVE BACKWARDS BOTH ARMS ARE BELT WITH THE PALMS FACING DOWNWARD AND THE FOREARMS MAKE SLOW MOVEMENTS AWAY FROM THE BODY.
	<ul style="list-style-type: none"> • END OF THE OPERATION BOTH HANDS ARE CLASPED AT CHEST HEIGHT.		<ul style="list-style-type: none"> • TO THE SIGNALMAN'S RIGHT THE RIGHT ARM IS EXTENDED MORE OR LESS HORIZONTALLY WITH THE PALM FACING DOWNWARDS AND SLOWLY MAKES SMALL MOVEMENTS TO THE RIGHT.
B. VERTICAL MOVEMENTS			
	<ul style="list-style-type: none"> • RAISE THE RIGHT ARM POINTS UPWARD WITH THE PALM FACING FORWARD AND SLOWLY MAKES A CIRCLE.		<ul style="list-style-type: none"> • TO THE SIGNALMAN'S LEFT THE LEFT ARM IS EXTENDED MORE OR LESS HORIZONTALLY WITH THE PALM FACING DOWNWARDS AND SLOWLY MAKES SMALL MOVEMENTS TO THE LEFT.
	<ul style="list-style-type: none"> • LOWER THE RIGHT ARM POINTS DOWNWARDS WITH THE PALM FACING INWARDS AND SLOWLY MAKES A CIRCLE.		<ul style="list-style-type: none"> • HORIZONTAL DISTANCE THE HANDS INDICATE THE RELEVANT DISTANCE.
		D. DANGER	
	<ul style="list-style-type: none"> • VERTICAL DISTANCE THE HANDS INDICATE THE RELEVANT DISTANCE.		<ul style="list-style-type: none"> • DANGER • DANGER OR EMERGENCY STOP BOTH ARMS POINT UPWARDS WITH THE PALMS FACING FORWARDS.

TAB. 57 (Hand signals - Directive 92/58/EEC)

19.4 ELECTRICAL SCHEMATICS

19.4.1 ELECTRICAL SCHEMATIC - SINGLE POWER SUPPLY

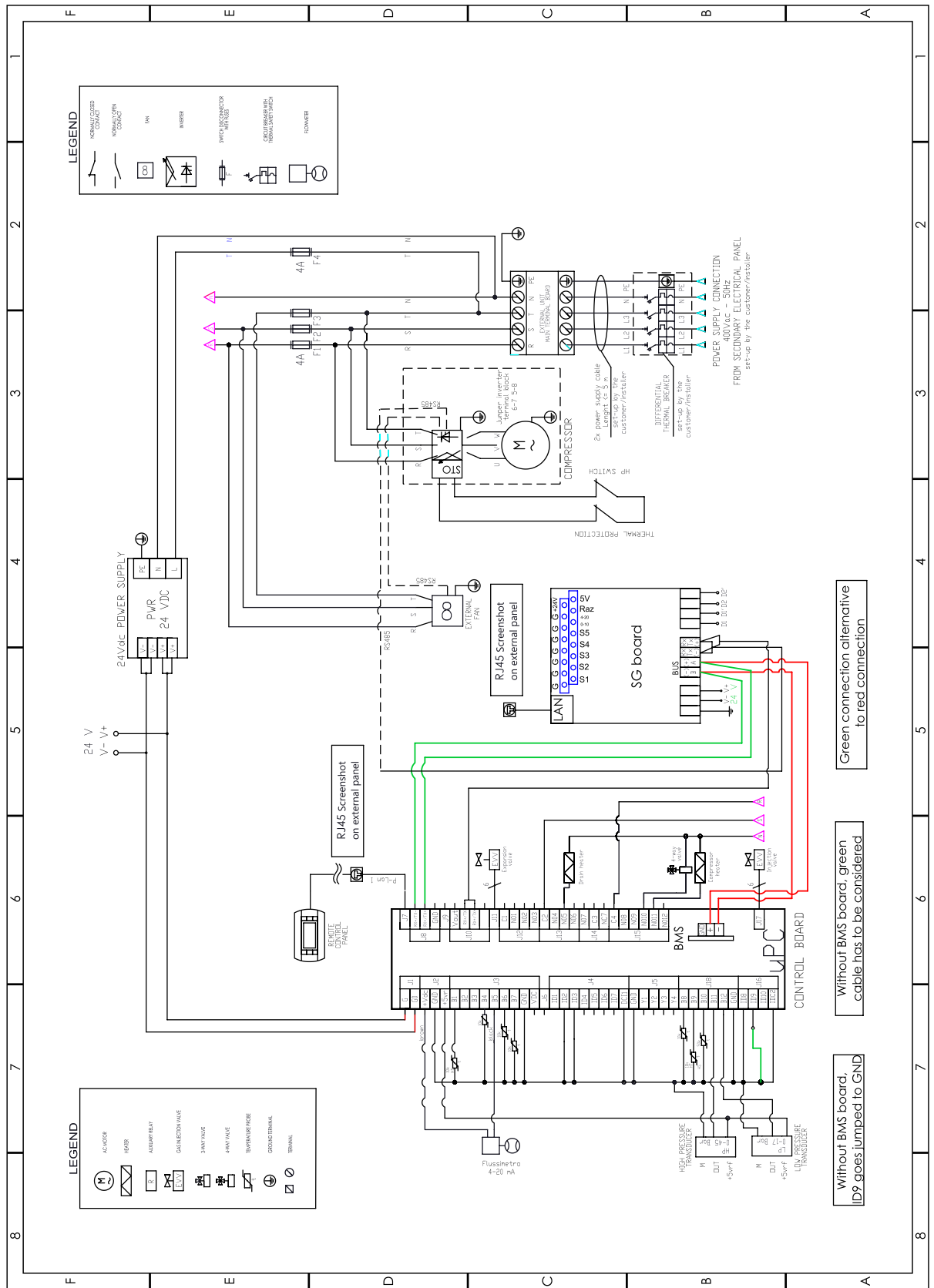

FIG. 82 (Electrical schematic - Single power supply)

19.4.2 ELECTRICAL SCHEMATIC - DUAL POWER SUPPLY

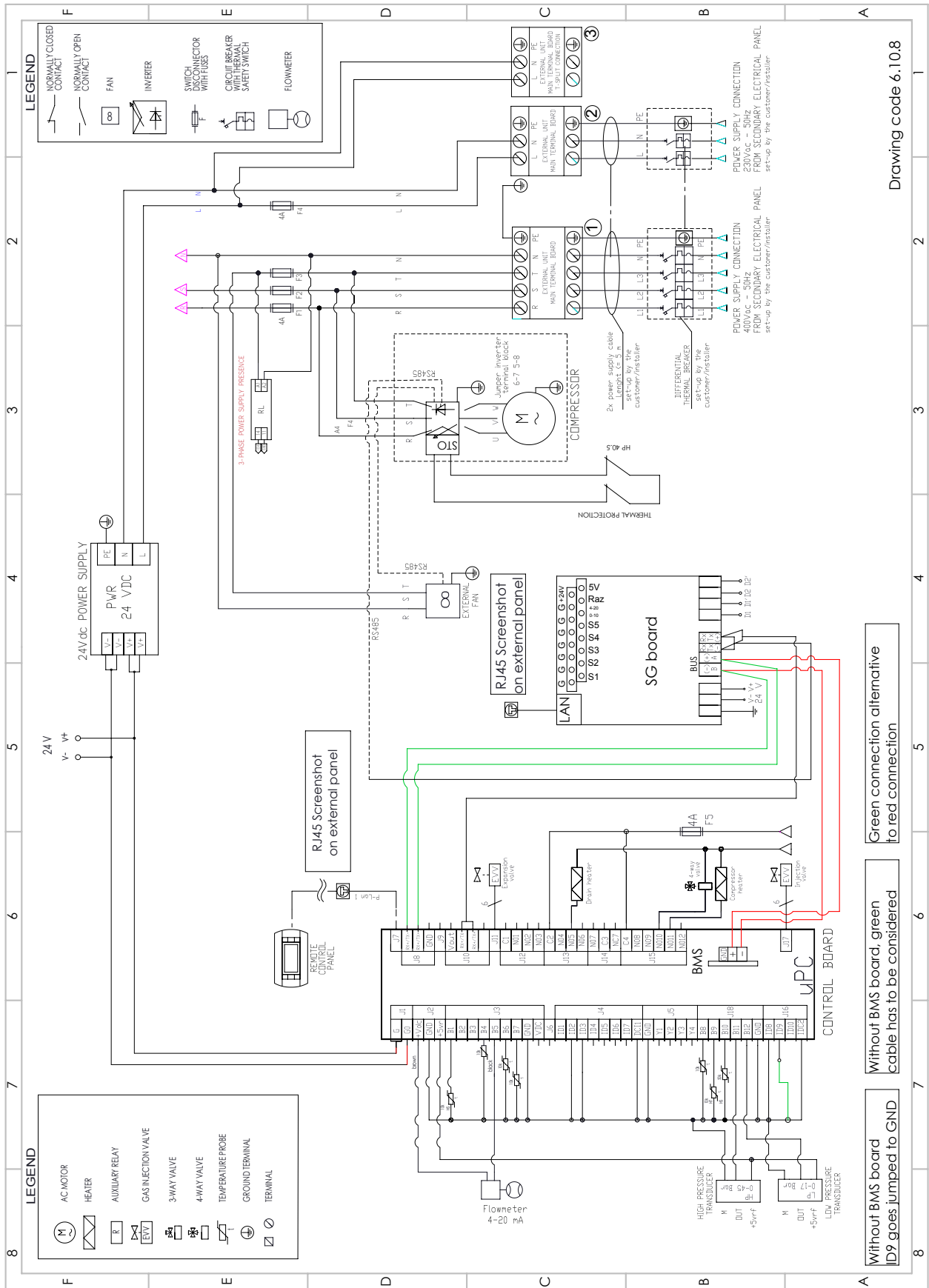

FIG. 83 (Electrical schematic - Dual power supply)

Without BMS board, green cable has to be considered

Without BMS board, green cable has to be considered

Without BMS board, green cable has to be considered

19.5 INTERNAL WIRING CABLE DIAGRAM

19.5.1 CIRCULATION PUMP WIRING



Only in the case of a circulator on board the machine.

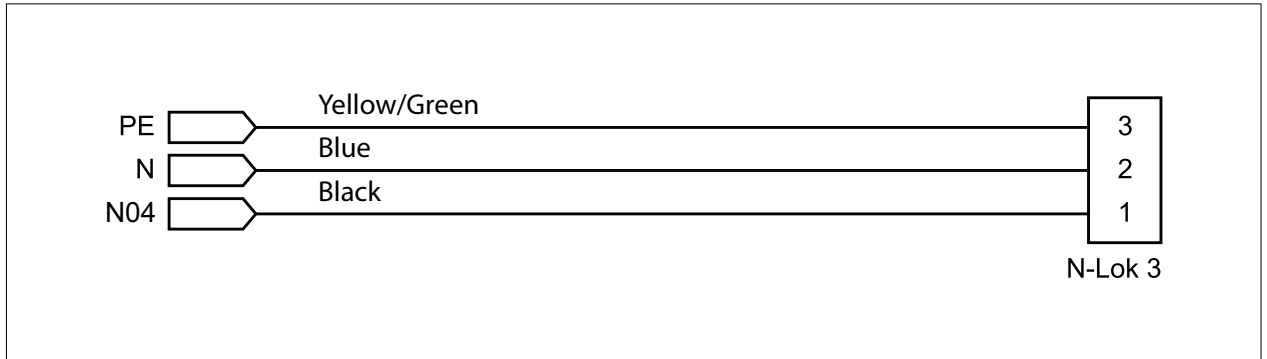

FIG. 84 (Circulation pump wiring)

19.5.2 FAN WIRING

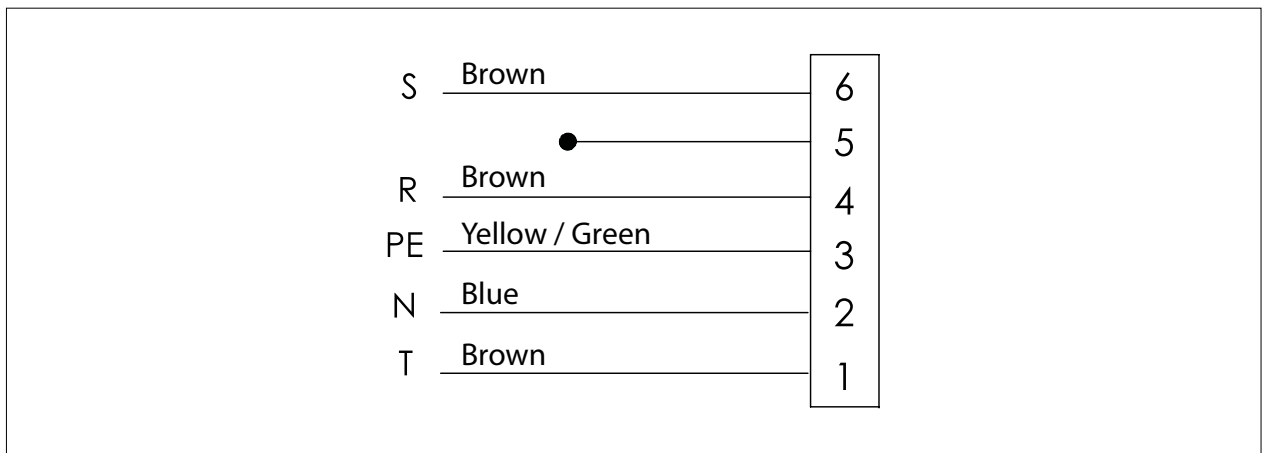

FIG. 85 (Fan wiring)

19.5.3 4-WAY VALVE AND CASING HEATING ELEMENT WIRING

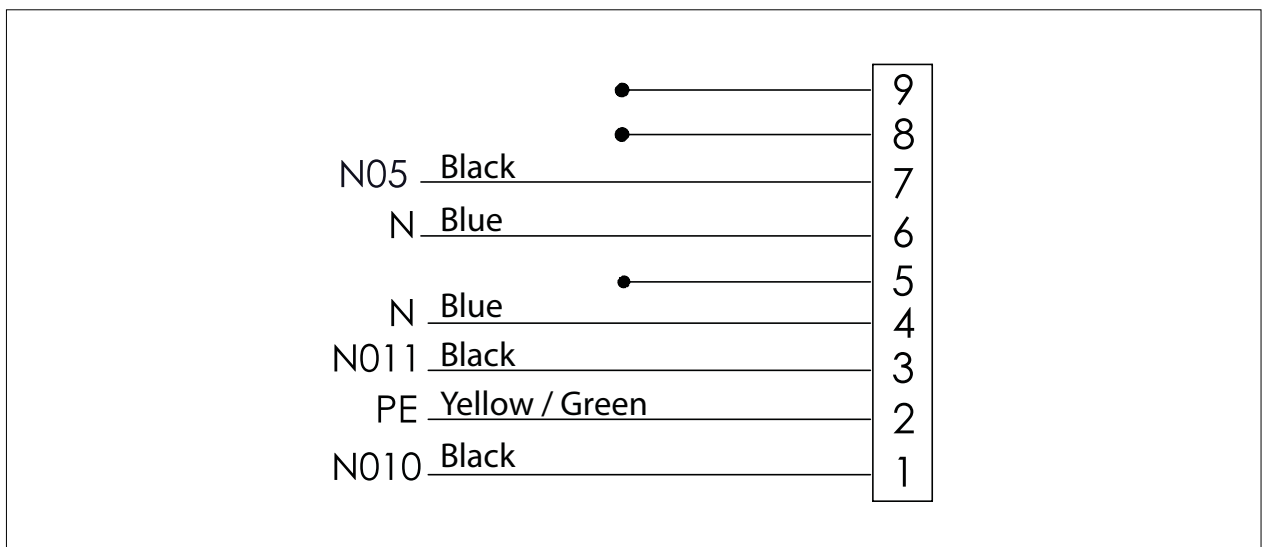

FIG. 86 (4-way valve and casing heating element wiring)

19.5.4 PROBE WIRING

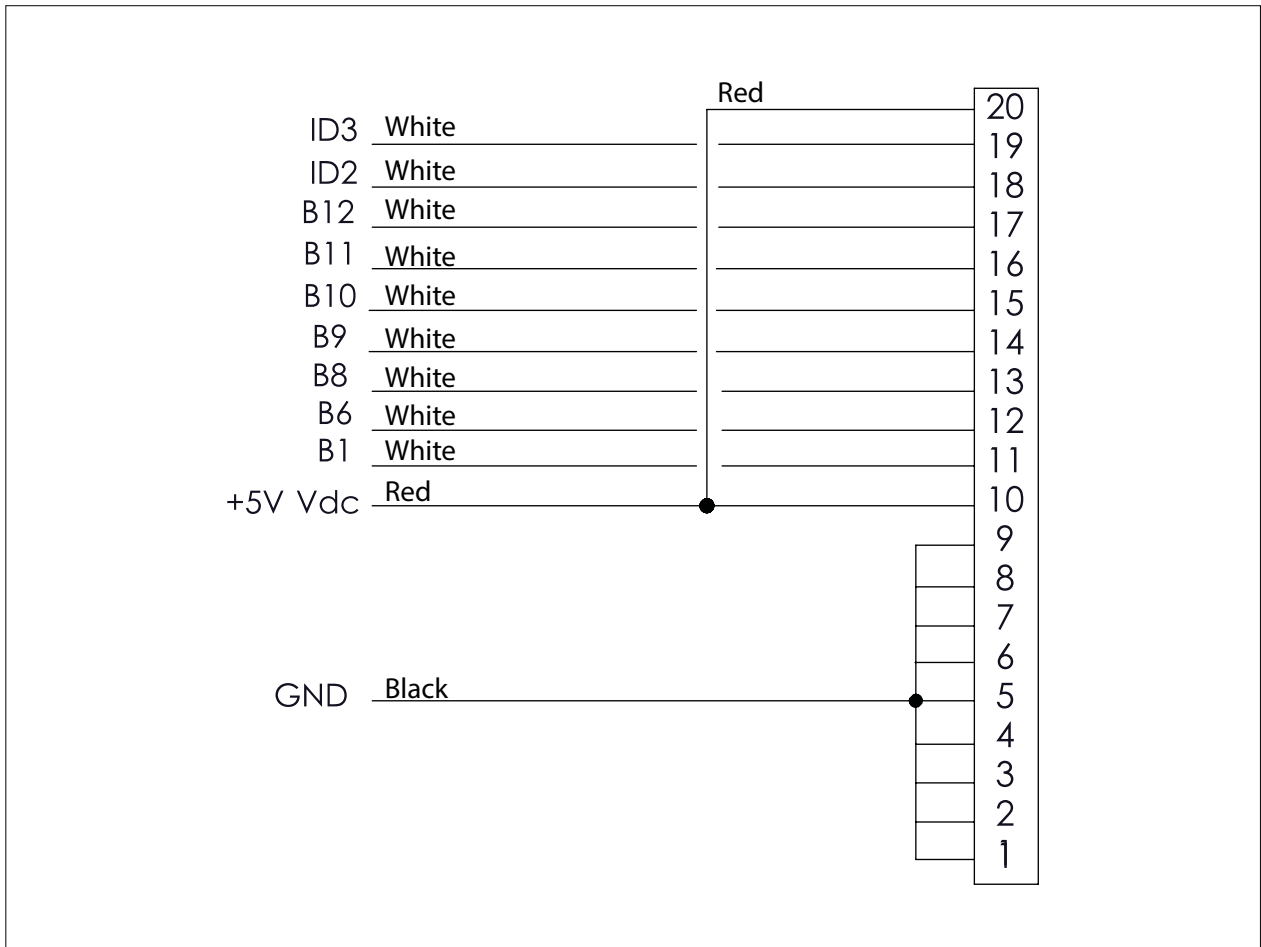

FIG. 87 (Probe wiring)

20 SUMMARY OF CHANGES

Date	Section/Paragraph	Modified
01/10/2025	13.11.9 TERMINAL BLOCK OF SECONDARY ELECTRICAL CABINET FOR DUAL-SUPPLY HEAT PUMP	Inserimento nuovo paragrafo
	19.4.2 ELECTRICAL SCHEMATIC - DUAL POWER SUPPLY	Aggiornamento schema elettrico doppia alimentazione
26/11/2025	5.6 CIRCULATORS	Inserimento circolatori in tabella
	5.7 LIMITS OF USE AND TECHNICAL DATA	Inserimento nuove tabelle con dati tecnici
	5.10.5 CIRCULATOR TEMPLARI GPA 32-17 H PRO/180	Inserimento di un nuovo paragrafo relativo alla rappresentazione delle curve di funzionamento e delle caratteristiche del circolatore.
	5.10.9 CIRCULATOR TEMPLARI GPA 25-13 H PRO/180	Inserimento di un nuovo paragrafo relativo alla rappresentazione delle curve di funzionamento e delle caratteristiche del circolatore.
	13.7 INSTALLING THE PROBE	Modifica testo
09/02/2026	13.9.10 INDICATIVE SECTION FOR CABLES AND INTERNAL PROTECTIONS	Aggiornamento dei dati presenti nella tabella
25/02/2026	13 INSTALLATION	Inserimento di dati aggiuntivi nel riquadro "INFORMATION"
13/03/2026	13.1 CHOICE OF INSTALLATION SITE	Aggiornamento dei dati presenti in tabella
	13.2.3 SAFETY ZONE FOR GROUND INSTALLATION IN A BUILDING CORNER	Aggiornamento dei dati in tabella e dei disegni tecnici
	13.2.5 SAFETY ZONE FOR WALL INSTALLATION IN A BUILDING CORNER	Aggiornamento dei dati in tabella e dei disegni tecnici
22/04/2026	5.6 CIRCULATORS	Aggiornamento dato in tabella



TEMPLARI SPA

Via C. Battisti, 169 - 35031 Abano Terme (PD) Italy

Tel. +39 049 5225929 - mail: info@templari.com - www.templari.com