

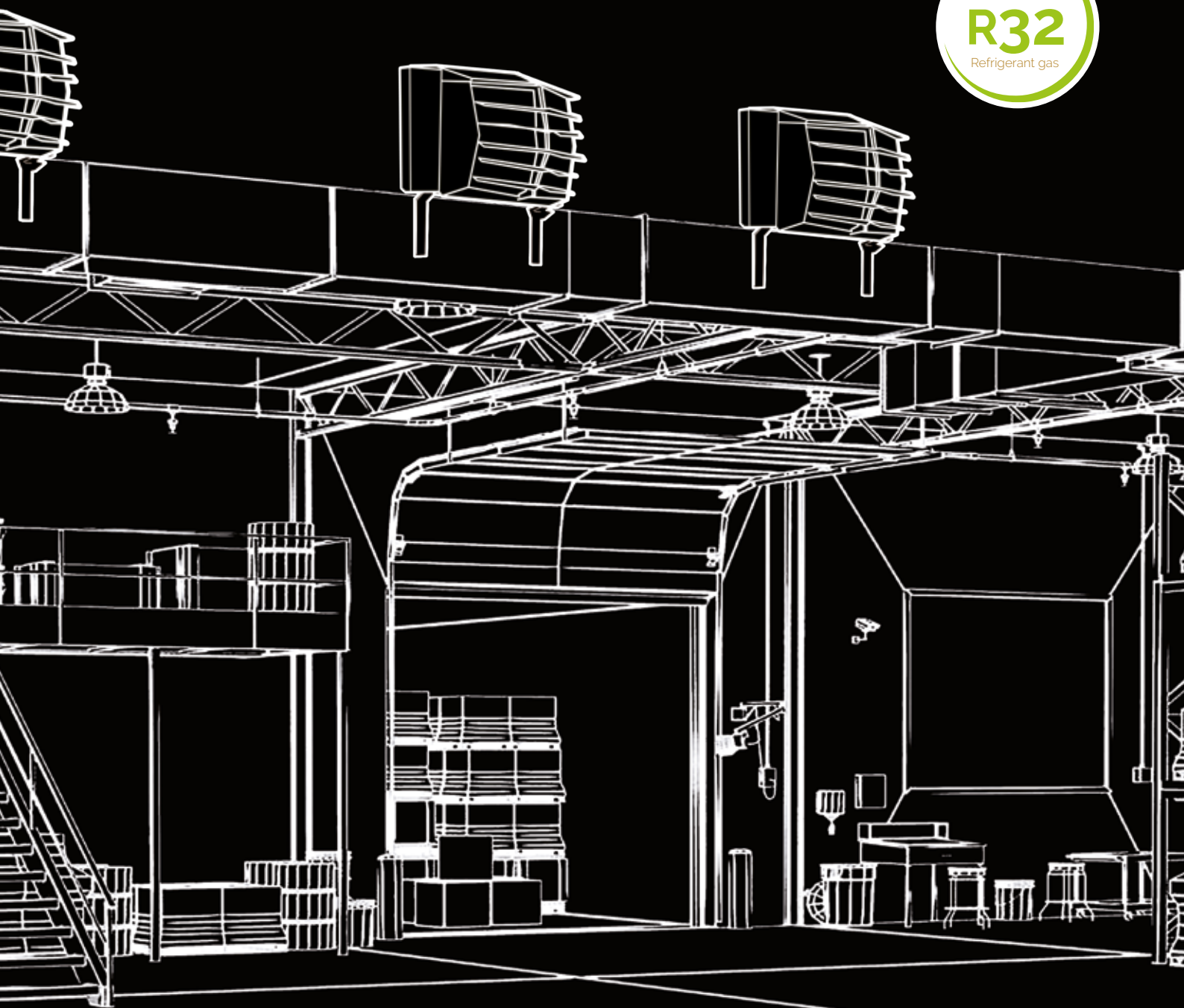

AIR TO AIR INSTALLATION MANUAL



Summary

1	Introduction.....	4
1.1	General Notes.....	4
1.2	Suggested tools.....	4
1.3	Series description	4
2	Read Carefully before use	5
2.1	Important information.....	5
2.2	Important information regarding the refrigerant used.....	5
2.3	Proper use	6
2.4	Standards and statutory provisions.....	6
2.5	Instructions for disposal.....	6
2.6	Energetic saving	6
3	Expected use of the heat pump.....	6
3.1	Operating area e safe devices.....	6
3.2	Allowed operative zone	6
3.3	Heat pump structure.....	7
3.4	Operation mode.....	7
4	Equipment supplied	7
4.1	Main unit.....	7
4.2	Name and serial number.....	7
4.3	External unit components diagram for Templari® KITA AIR R32 version with chiller compartment electric board	9
4.4	External unit components diagram for Templari® KITA AIR R32/KITA AIR COLD R32 heat pump version with under-top electric board.....	10
4.5	External unit components diagram for Templari® KITA AIR PLUS R32 heat pump version with chiller compartment electric board.....	11
4.6	External unit components diagram for Templari® KITA AIR PLUS R32 heat pump version with under-top electric board	12
4.7	Internal unit components diagram for Templari® KITA AIR R32/AIR COLD R32/AIR PLUS R32 heat pump	13
4.8	Internal unit components diagram (duct version) for Templari® KITA AIR R32/AIR COLD R32/AIR PLUS R32 heat pump.....	14
5	Transport	15
6	Mounting and installation.....	15
6.1	Equipment check	15
6.2	External unit measurements	15
6.3	Free spaces for the assembly	16
6.4	Choice of installation place	16
6.5	External unit mounting	17
6.6	Condensate discharge preparation.....	17
6.7	Correct alignment	18
7	Installation and assembly of the internal unit	18
7.1	Internal unit sizes KITA AIR R32/KITA AIR COLD R32/AIR PLUS R32	18
7.2	Duct unit sizes KITA AIR R32/KITA AIR COLD R32/AIR PLUS R32	19
7.3	Generalities and choice of the installation place	20
7.4	Assembly internal unit and correct positioning of B2 probe	20
8	Refrigerant circuit connection	22
8.1	Installation requirements.....	22
8.2	Set up for installation and refrigerant pipelines installation	22
8.3	Vacuum procedure.....	22
9	Maintenance and cleaning.....	23
9.1	Finned coil cleaning	23
9.2	Condensate discharge cleaning	23
9.3	Refrigerant circuit maintenance	23
10	Electric connection.....	23
10.1	General information.....	23
10.1.1	The customer/ installer has to:.....	24

10.2	Operations of laying	24
10.3	External unit connection	24
10.4	Internal unit connection.....	24
10.5	Probes and remote controller	24
10.6	Power supplying	24
10.6.1	Internal unit auxiliary heater (optional)	24
10.7	Power and signal cables characteristics	25
10.8	User electrical panel with μ PC control board.....	26
10.9	User electrical panel with μ kita control board.....	27
10.10	Internal unit terminal block.....	28
10.11	Indoor unit–outdoor unit connection for heat pumps with μ PC control board.....	30
10.12	Indoor unit–outdoor unit connection for heat pumps with μ Kita control board.....	31
10.13	K-Touch operator panel connection.....	32
11	K-Touch user panel.....	33
11.1	Warnings	33
11.2	K-Touch panel, electrical connections.....	33
11.3	Connection to the heat pump and simultaneous PGD use - only for heat pumps with μ PC control board	33
12	Main electrical panel, for units with μ PC control unit.....	36
12.1	Wiring of the outdoor unit electronic controller in the main electrical panel for units with μ PC control board	36
12.2	SG-Probe electronic board	38
13	Wiring and pinout of the outdoor unit electronic controller	39
13.1	Main electrical panel for units with μ Kita electronic control board.....	39
13.2	BUS Communication Ports	40
13.3	WEB Communication Port.....	40
13.4	Digital inputs	41
13.5	Digital outputs	42
13.6	Analogue Inputs.....	43
13.7	PWM OUTPUT	44
13.8	Expansion valve outputs	45
13.9	Power supply ports	45
14	Smart-Grid	46
14.1	Smart-Grid operation	46
14.2	Enabling SG functions via the PGD and K-touch panel	46
14.3	Example of SG-Ready connection for units with μ PC and μ Kita electronic control boards.....	47
15	Multi-Air	48
15.1	Overview of Multi-Air connectionfor heat pumps with a μ PC electronic control board	48
15.2	Overview of the Multi-Air connection for heat pumps with a μ Kita electronic control board.....	49
16	Electric boards	50
16.1	Chiller compartment electric board.....	50
16.2	Primary and secondary electrical panel for units with μ PC.....	51
17	Wiring diagrams.....	52
17.1	Wiring diagram of the outdoor Air R32 unit – heat pump with μ PC electronic control board	52
17.2	Electrical diagram of outdoor Air R32 unit – single power supply – heat pump with μ Kita electronic control board	53
17.3	Electrical diagram of outdoor Air R32 unit – dual power supply – heat pump with μ Kita electronic control board	54
17.4	AIR R32 internal unit wiring diagram, including auxiliary heater (optional)	55
18	Commissioning	56
18.1	Preliminary controls.....	56
18.2	Commissioning	56
19	Alarms	57
19.1	Alarms resolution	59
19.2	Notifications	59
20	Summary of changes.....	60

1 Introduction

This manual aims to give all the necessary information installation and proper operation of **KITA - AIR Templari®** heat pump, from its start-up and for all its life cycle. The document is divided into chapters, each of which contains general information and procedures to be performed.



This product contains fluorinated greenhouse gases covered by the Kyoto Protocol. Do not vent gases into the atmosphere.

The heat pump uses a flammable refrigerant, R32 (category A2L). For installation and maintenance take extreme care that there are no sources of ignition in the working area and comply with the requirements in paragraph 6.4.

1.1 General Notes

- The selection and the use of the unit that serves the plant shall be carried out by competent staff in accordance with regulations in place, so as to fully satisfy the demands of the system.
- Installation, commissioning and maintenance must be performed by competent staff that must be able to assess risk factors or malfunctioning of the machine.
- The unit is directly supplied by the manufacturer with all the options and functionalities. Tampering with any part of the refrigerator circuit or the software are not allowed. Any tampering will invalidate the manufacturer responsibilities.
- Regular inspections and proper maintenance of the heat pump **KITA - AIR Templari®** can prevent damages and any costs for repairs.
- The warranty is void for an installation that doesn't meet the specifications.
- Keep this manual with the necessary diagrams in an easily accessible place.
- In case of malfunctioning, check the error code on the control panel, if necessary contact the installer. If necessary, please request for original parts.
- You can find all informations on the KITA Templari® label, in accordance with the regulation on labeling, in particular you can find:
 - Voltage and frequency of Power supply of the machine;
 - Thermal power in heating and cooling;
 - Maximum power consumption;
 - Sound power level;
 - The refrigerant utilized.

1.2 Suggested tools

- Set of screwdrivers;
- Cutter;
- Scissors;
- Set of wrenches or pipe wrenches;
- Ladder;
- Pumber material to seal the threads;
- Electrical equipments for connections;
- Protective gloves;
- Testers and current clamp;

1.3 Series description

KITA - AIR Templari® heat pump series presents air to air machines which are composed by an external and internal unit (aerothermal unit) for heating and cooling in big spaces applications.

KITA - AIR Templari® is full-inverter with high performance and generously sized component to reach high energy efficiencies. Another feature is the EVI technology (Enhanced Vapour Injection) that enlarges the operating zone and the thermal power of the machine. The R-32 refrigerant allows the achievement of high performances and low environmental impact. Full reliability and optimal functionality are ensured by two electronic valves, a 4-ways valve, pressure transducers, temperature probes, controlled by the electronics onboard. The user can control the whole machine functionalities by a remote panel controller: by this control it is possible to change the setpoint and the working mode (summer/winter) and to monitoring the operations.

Internal unit

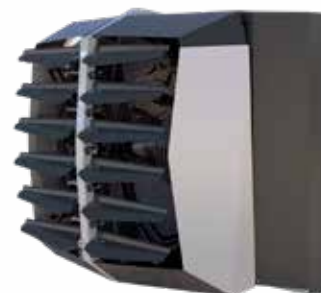

External unit

2 Read Carefully before use

2.1 Important information

⚠ ATTENTION!!

The use and the maintenance of the **KITA - AIR Templari®** heat pump, are subjected to the juridical ordinances of the destination country. Depending on the amount of refrigerant you need to check and note the tightness of the heat pump at regular intervals referring to qualified personnel.

- During transport it's possible tilt the external unit not over 45° (in any direction).
- **Transport protection must be removed before to commissioning.**



- Don't cover or reduce the suction area.
- Comply with the building regulations specific to individual countries.
- If the heat pump is installed near the wall, be careful to the influence of building physics factors. Make sure that there aren't windows in the fan discharge area.
- If the heat pump is installed near a wall, there is a higher risk of deposit of impurities. Besides, external air moved by the heat pump must escape in order to not increase the building thermal losses.
- It is not allowed the installation of the external unit or of the monoblock in niches or in interior courtyards, because the cooled air accumulates on the ground and in the case of prolonged functioning would be aspirated again by the heat pump.
- The frosting limit can change depending on climate region. Respect the regulations of the countries concerned.
- Observe correct rotational direction: in case of incorrect wiring the start of the heat pump is hindered. The unit presents a phase monitoring that indicates the correct connection.
- The heat pump could stop operations in case of too low external temperature. In case of long time power cut, please see the commissioning procedure explained forward.
- Before opening the device, make sure to switch off all the electronics.
- Only qualified staff of the customer service can operate on the device.

2.2 Important information regarding the refrigerant used

This product contains fluorinated greenhouse gases covered by the Kyoto Protocol. Do not vent gases into the atmosphere.

Refrigerant type: R410A

GWP(1) value: 675

(1) GWP = global warming potential

Please fill in with indelible ink,

- ① the factory refrigerant charge of the product,
 - ② the additional refrigerant amount charged in the field and
 - ①+② the total refrigerant charge
- on the fluorinated greenhouse gases label supplied with the product.

The filled out label must be applied to the product near the product's serial label.

📖 **Contiene gas fluorurati ad effetto serra inclusi nel protocollo di Kyoto**
Contains fluorinated greenhouse gases covered by the Kyoto Protocol
Enthält fluorierte Treibhausgase, die durch das Kyoto-Protokoll abgedeckt werden
D

R32

① = Kg A

② = Kg B

① + ② = Kg C

③

① **Carica di refrigerante di fabbrica del prodotto: vedi targhetta con il nome dell'unità / Factory refrigerant charge of the product: see unit name plate / Werkseitige Kältemittelbefüllung des Produktes: siehe Typenschild der Einheit**

② **Quantità di refrigerante aggiuntiva nel campo / Additional refrigerant amount charged in the field / Zusätzliche am Montageort befüllte Kältemittelmenge**

③ **Carica di refrigerante totale / Total refrigerant charge / Gesamte Kältemittelbefüllung**

- A** factory refrigerant charge of the product: see unit name plate
- B** additional refrigerant amount charged in the field
- C** total refrigerant charge
- D** Contains fluorinated greenhouse gases covered by the Kyoto Protocol
- E** outdoor unit
- F** refrigerant cylinder and manifold for charging

i NOTE!

National implementation of EU regulation on certain fluorinated greenhouse gases may require to provide the appropriate official national language on the unit. Therefore an additional multilingual fluorinated greenhouse gases label is supplied with the unit. Sticking instructions are illustrated on the backside of that label.

2.3 Proper use

La pompa di calore Kita AIR R32 è omologata solo per l'uso previsto dal costruttore. È vietato apportare modifiche o trasformazioni all'apparecchio.

La Dichiarazione di Conformità (CE) è limitata a quanto fornito dal costruttore e rimane valida a condizione che l'oggetto della dichiarazione sia utilizzato e mantenuto in conformità con le norme vigenti e alle raccomandazioni del manuale di istruzioni. La dichiarazione viene a decadere qualora vengono apportate modifiche non rientranti nella ordinaria e straordinaria manutenzione e alle indicazioni riportate nel manuale d'uso e manutenzione.

2.4 Standards and statutory provisions

The heat pump in question is, according to Article 1, Chapter 2 k) of EC Directive 2006/42/EC (Machinery Directive), intended for domestic use and is, therefore, subject to the requirements of Directive 2014/35/EU (Low Voltage Directive). This makes it suitable for use by inexperienced persons for the heating of shops, offices and other similar workplaces, farms, hotels, boarding houses and the like, or other residential facilities.

All corresponding EC directives as well as DIN and VDE standards were observed in the design and manufacture of the heat pump (see EC Declaration of Conformity).

The electrical connection of the KITA Templari® heat pump must be carried out in accordance with the applicable VDE, EN and IEC standards. In addition, the conditions governing the connection of mains supply network operators must be observed.

Persons, especially children, who on the basis of their physical, sensory or mental abilities or due to inexperience or lack of expertise, are unable to use the device safely, must not use the device without the supervision or guidance of a competent person. Ensure that children do not play with the device.



2.5 Instructions for disposal

PRODUCT COMPLIES WITH EU DIRECTIVE 2012/19/EU-LEGISLATIVE DECREE 49/2014 pursuant to Art. 26 of Legislative Decree No. 49 of 14 March 2014 "Implementation of Directive 2012/19/EU on waste electrical and electronic equipment (WEEE)".

The crossed-out wheellie bin symbol on the equipment or its packaging indicates that the product must be collected separately from other waste at the end of its useful life.

The removal of the appliance, as well as the retrieval of coolant, oil or any other parts, must be carried out in accordance with local and national legislation.

Do not attempt to dismantle the system yourself. Removal of the system, as well as the retrieval of refrigerant, oil or any other parts, must be carried out by a qualified installer in accordance with current local and national legislation.

The units must be processed at a facility specialising in material reuse, recycling and recovery. Proper disposal of the product will prevent potential negative consequences to the environment as well as human health. Contact your installer or local authorities for further information.

2.6 Energy saving

By using a KITA Templari® heat pump, you contribute to safeguarding the environment. A prerequisite for reducing energy consumption is an effective arrangement of heat sources and system to utilise thermal energy.

Of particular importance for the effectiveness of a heat pump is to keep the temperature difference between the outside and inside room air as low as possible. This is why careful sizing of the heat source and heating system is highly recommended. A temperature difference greater than one degree Kelvin (1°C) leads to an increase in energy consumption of approximately 2.5%.

Avoid placing the indoor unit in particularly dirty or dusty working environments, which may otherwise lead to deposits on the coil, limiting heat exchange and efficiency. The same applies to the case of corrosive volatile substances.

3 Expected use of the heat pump

3.1 Operating area e safe devices

KITA AIR Templari® heat pump has to be used with external air temperature between -25°C and 45°C.

Internal air temperature range:

- **Heating:** min. temperature 10°C, max. temperature 28°C
- **Cooling:** min. temperature 16°C, max. temperature 35°C
- KITA AIR Templari® heat pump is equipped by a pressure switch that stops the machine operations when a pressure of 4.05 MPa (40.5 bar) is reached.

⚠ ATTENTION!

Make sure to switch off the device and to disconnect it from the electric connection before performing maintenance. In particular, make sure that the main switch installed near the external unit is switched off.

- KITA AIR Templari® heat pump is equipped by a discharge temperature probe that controls the discharge temperature.

ⓘ NOTE!

The device is not suitable for use with an external inverter. If the machine is powered off (disconnected from the net) for long periods, do not interrupt the procedure of the oil warming that starts when the machine is powered once again. This procedure prevents the compressor breakdown.

3.2 Allowed operative zone

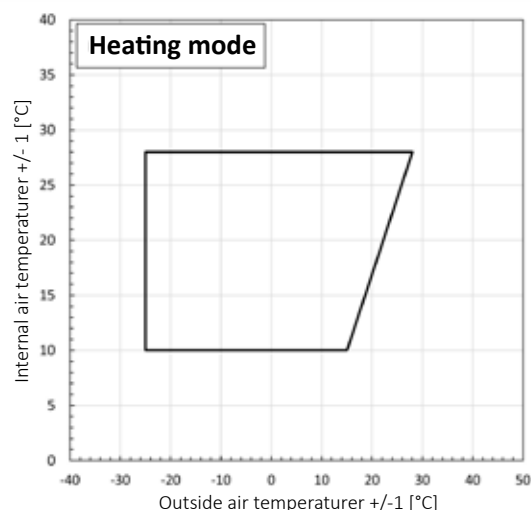

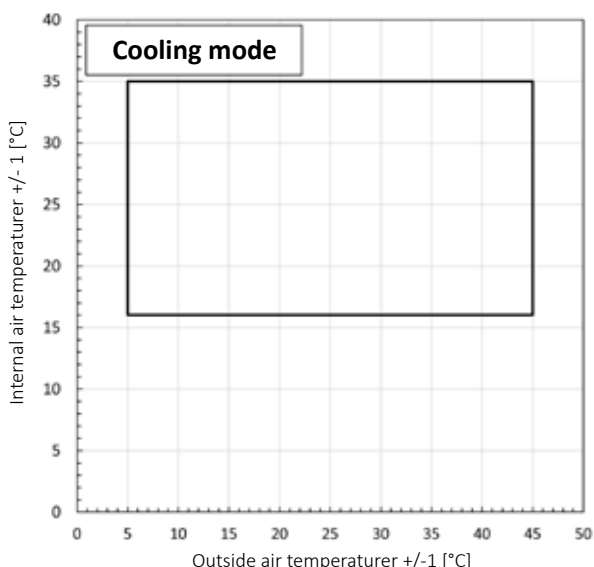

Cooling mode

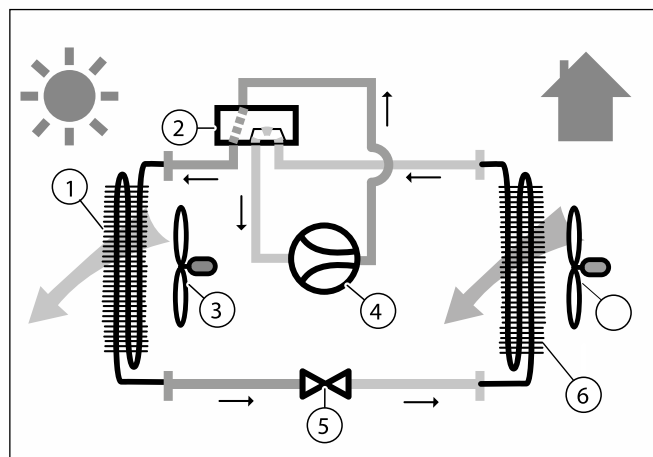

- | | | | |
|---|------------|---|----------------------------|
| 1 | Evaporator | 5 | Electronic expansion valve |
| 2 | 4-W valve | 6 | Internal unit exchanger |
| 3 | Fan | | |
| 4 | Compressor | | |

3.3 Heat pump structure

The heat pump system includes the following components:

- The KITA AIR Templari® external unit contains the refrigerant circuit;
- KITA AIR Templari® internal unit (aerothermal) for the diffusion of the air inside ambient;
- Remote control panel;
- B2 temperature probe.

3.4 Operation mode

The heat pump can operate in two modes, actionable through the switching of the 4 way valve: as shown below, these modes are heating and cooling.

Heating mode

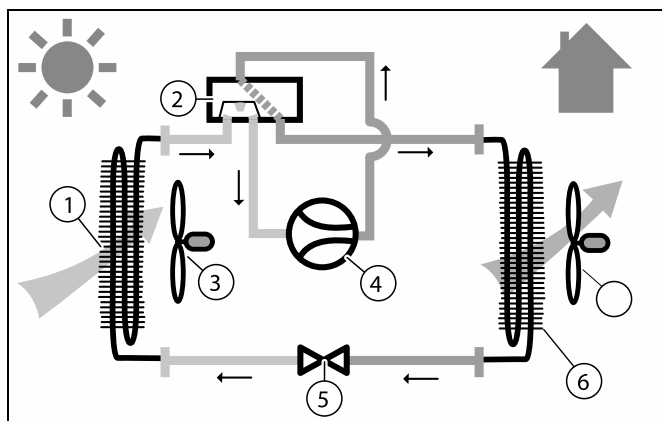

- | | | | |
|---|------------|---|----------------------------|
| 1 | Evaporator | 5 | Electronic expansion valve |
| 2 | 4-W valve | 6 | Internal unit exchanger |
| 3 | Fan | | |
| 4 | Compressor | | |

4 Equipment supplied

4.1 Main unit

The KITA AIR Templari® heat pump is provided in 2 units and it consists of components which are indicated at page 4.

4.2 Name and serial number

The name of the model and the serial number are indicated on the plate (2). Figure 1.

figure 1

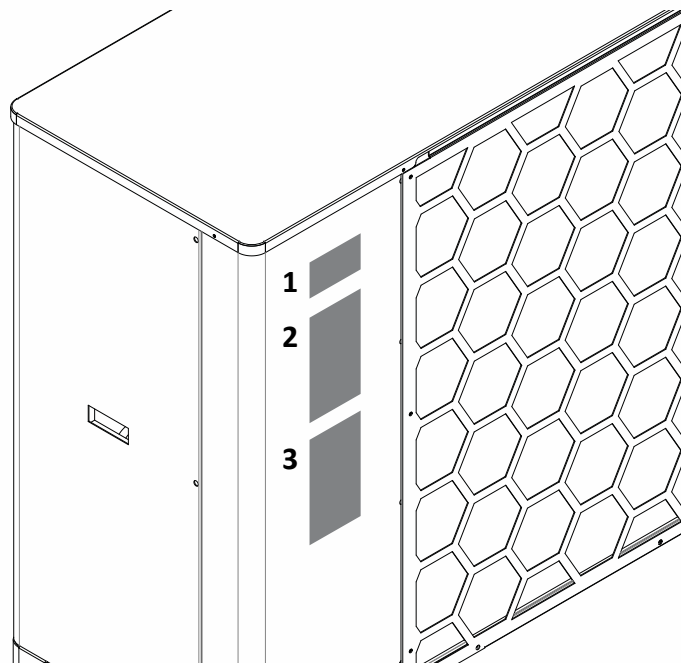

LABELS



- 1 – R-32 warning label
- 2 – identification label
- 3 – refrigerant charge label

1 – R-32 warning label

R-32

This equipment contains fluorinated greenhouse gases covered by the Kyoto Protocol.

Questa apparecchiatura contiene gas fluorurati ad effetto serra inclusi nel protocollo di Kyoto.

Read the instruction manual carefully before making any operation.
Leggere attentamente il manuale di istruzioni prima di effettuare qualsiasi operazione.

2 – identification label



Templari S.p.a.
Via C. Battisti, 169 Abano Terme - PD
info@templari.com - +39 049 8597400

Heat pump/Chiller / Pompa di calore

Serial number / Numero di serie	K-----
Model number / Numero modello	4.3.1.4
Model name / Nome modello	KITA AIR con R-32
Year of production / Anno di produzione	2022
Heating capacity / Potenza termica @ A7/A20	39 kW
Cooling capacity / Potenza frigorifera @ A35/A27	35 kW
Rated voltage / Alimentazione	3~400V - 50 Hz
Max operating current / Max corrente assorbita	24A
Refrigerant / Refrigerante	R32
Refrigerant Charge / Carica di refrigerante	7,4 kg
CO2 equivalents / CO2 equivalente	4995 Kg
PED Category / Categoria PED	II
Max permissible pressure / Pressione massima ammissibile	PS 40,5 bar
Net Weight (Outdoor Unit / Indoor Unit) / Peso netto (unità esterna/unità interna)	280 / 140 Kg

-----22
Made in Italy



0425



Contains fluorinated greenhouse gases covered by the Kyoto Protocol

R-32

Note: Heating capacity tested in standard condition of temperature: external air temperature of 7°C (dry bulb) and 6°C (wet bulb), internal air temperature inlet/outlet 15/20°C. Cooling capacity tested in standard condition of temperature: external air temperature of 35°C (dry bulb) and 24°C (wet bulb), internal air temperature inlet/outlet 27/19°C. Tests in accordance with EN14511.



3 – refrigerant charge label



Contiene gas fluorurati ad effetto serra inclusi nel protocollo di Kyoto
Contains fluorinated greenhouse gases covered by the Kyoto Protocol
Enthält fluoridierte Treibhausgase, die durch das Kyoto-Protokoll abgedeckt werden

R32

① = Kg

② = Kg

① + ② = Kg

③

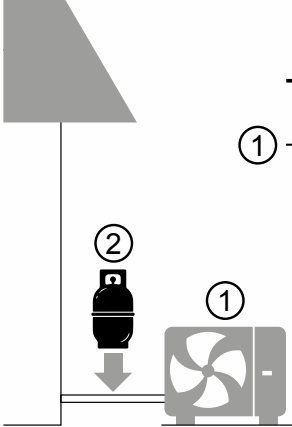

- ① Carica di refrigerante di fabbrica del prodotto: vedi targhetta con il nome dell'unità / *Factory refrigerant charge of the product: see unit name plate / Werkseitige Kältemittelbefüllung des Produktes: siehe Typenschild der Einheit*
- ② Quantità di refrigerante aggiuntiva nel campo / *Additional refrigerant amount charged in the field / Zusätzliche am Montageort befüllte Kältemittelmenge*
- ③ Carica di refrigerante totale / *Total refrigerant charge / Gesamte Kältemittelbefüllung*

To fill in the gas refrigerant label, make reference to par. 2.2

4.3 External unit components diagram for Templari® KITA AIR R32 version with chiller compartment electric board

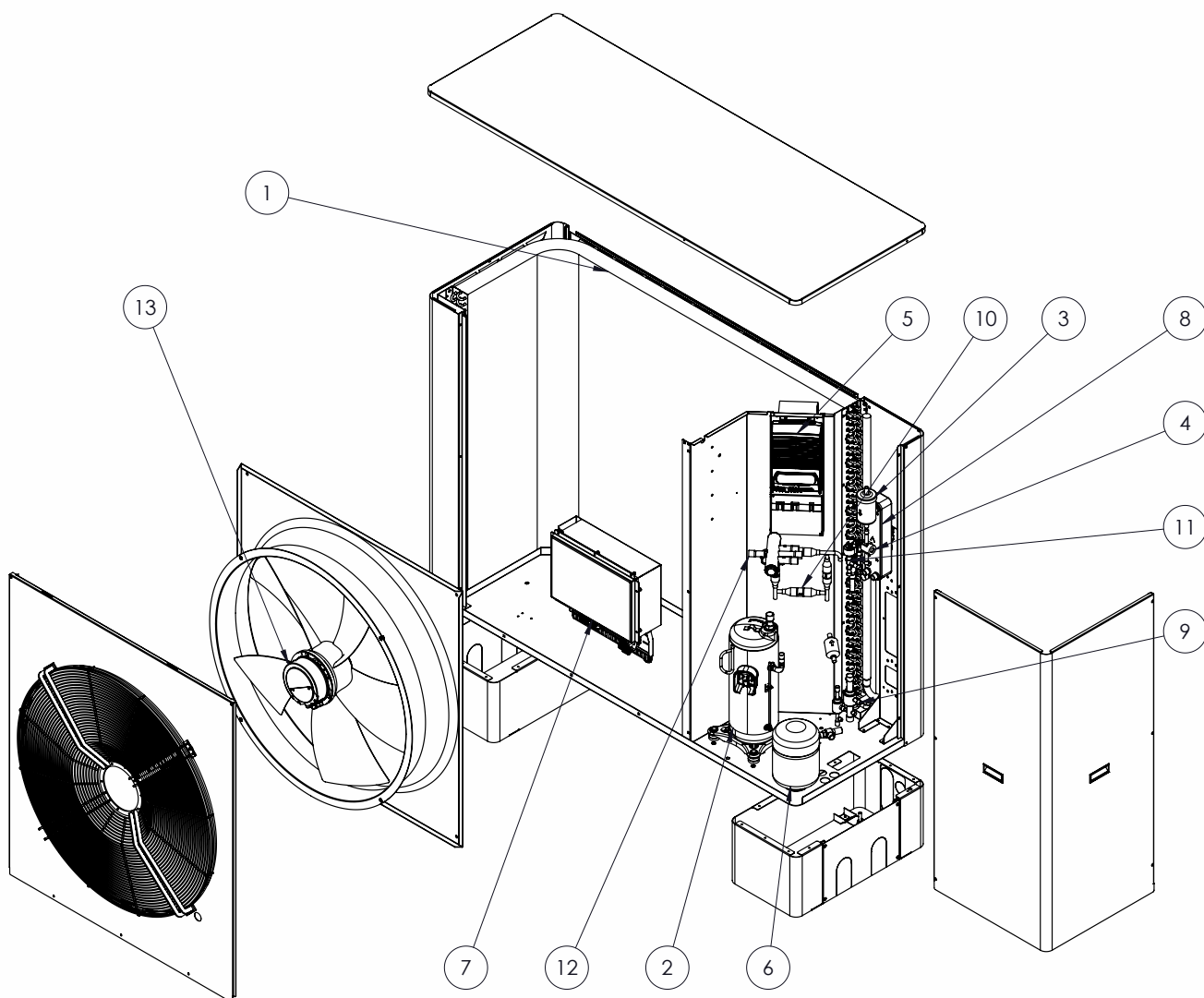

1	EVAPORATOR	8	ECONOMIZER
2	COMPRESSOR	9	BALL VALVES
3	FILTER	10	CHECK VALVES
4	LIQUID INDICATOR	11	ELECTRONIC EXPANSION VALVE
5	INVERTER	12	4-WAY VALVE
6	LIQUID RECEIVER	13	FAN
7	ELECTRIC BOARD		

The picture has the sole purpose of indicating the main internal components. The product may not be exactly as shown in the picture.

4.4 External unit components diagram for Templari® KITA AIR R32/KITA AIR COLD R32 heat pump version with under-top electric board

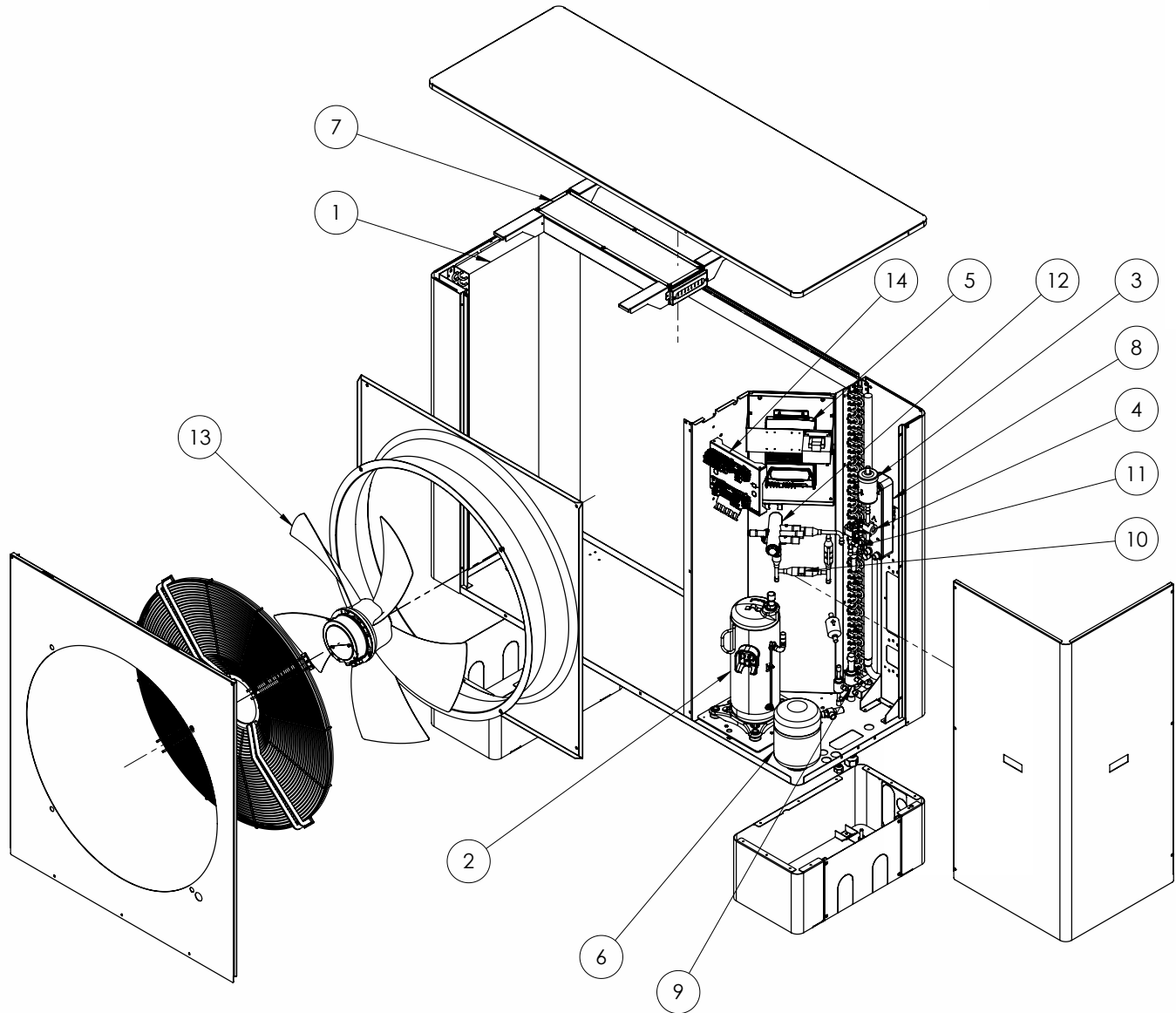

1	EVAPORATOR	8	ECONOMIZER
2	COMPRESSOR	9	BALL VALVES
3	FILTER	10	CHECK VALVES
4	LIQUID INDICATOR	11	ELECTRONIC EXPANSION VALVE
5	INVERTER	12	4-WAY VALVE
6	LIQUID RECEIVER	13	FAN
7	ELECTRIC BOARD	14	SECONDARY ELECTRIC BOARD

The picture has the sole purpose of indicating the main internal components. The product may not be exactly as shown in the picture.

4.5 External unit components diagram for Templari® KITA AIR PLUS R32 heat pump version with chiller compartment electric board

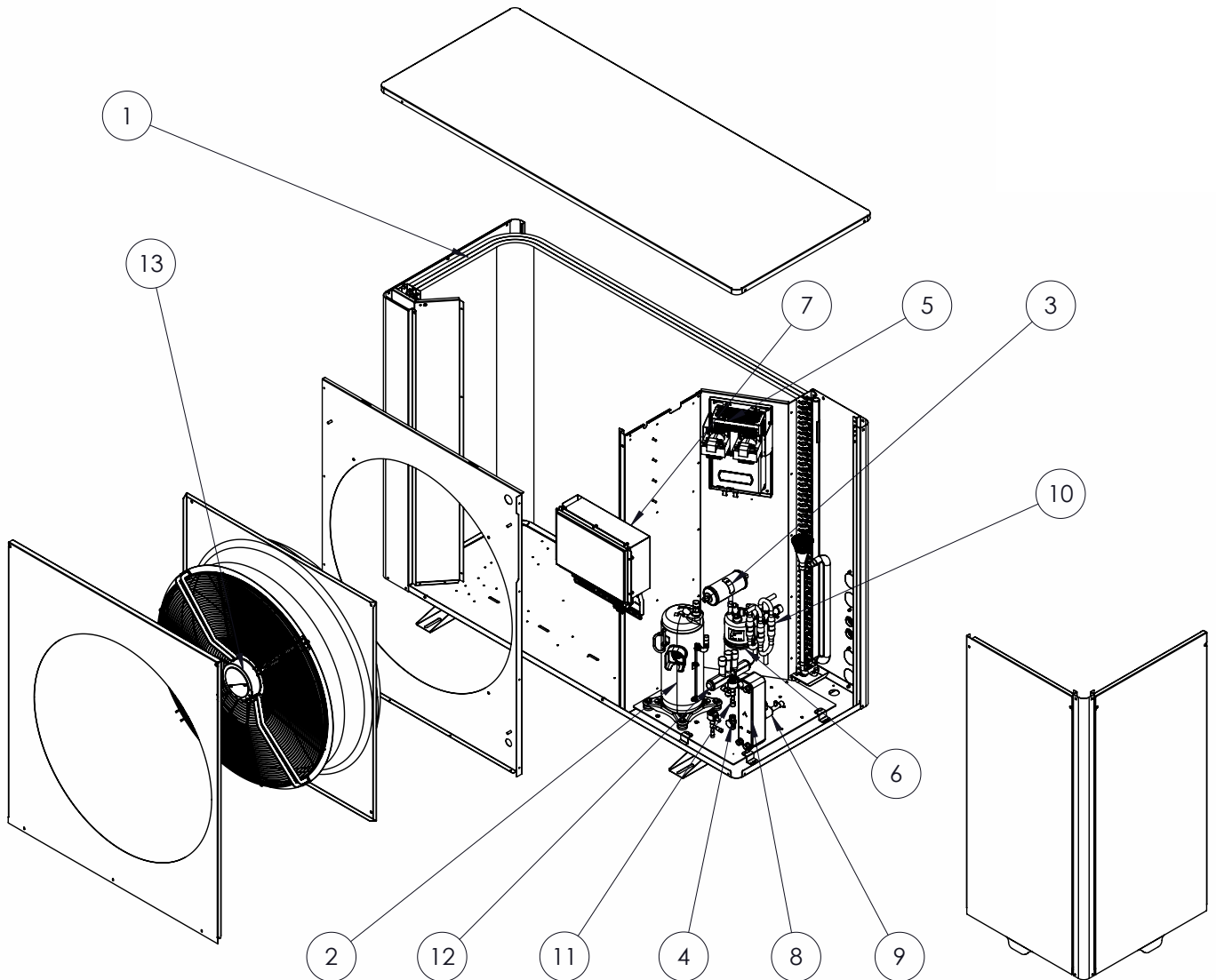

1	EVAPORATOR	9	BALL VALVES
2	COMPRESSOR	10	CHECK VALVES
3	FILTER	11	ELECTRONIC EXPANSION VALVE
4	LIQUID INDICATOR	12	4-WAY VALVE
5	INVERTER	13	FAN
6	LIQUID RECEIVER		
7	ELECTRIC BOARD		
8	ECONOMIZER		

The picture has the sole purpose of indicating the main internal components. The product may not be exactly as shown in the picture.

4.6 External unit components diagram for Templari® KITA AIR PLUS R32 heat pump version with under-top electric board

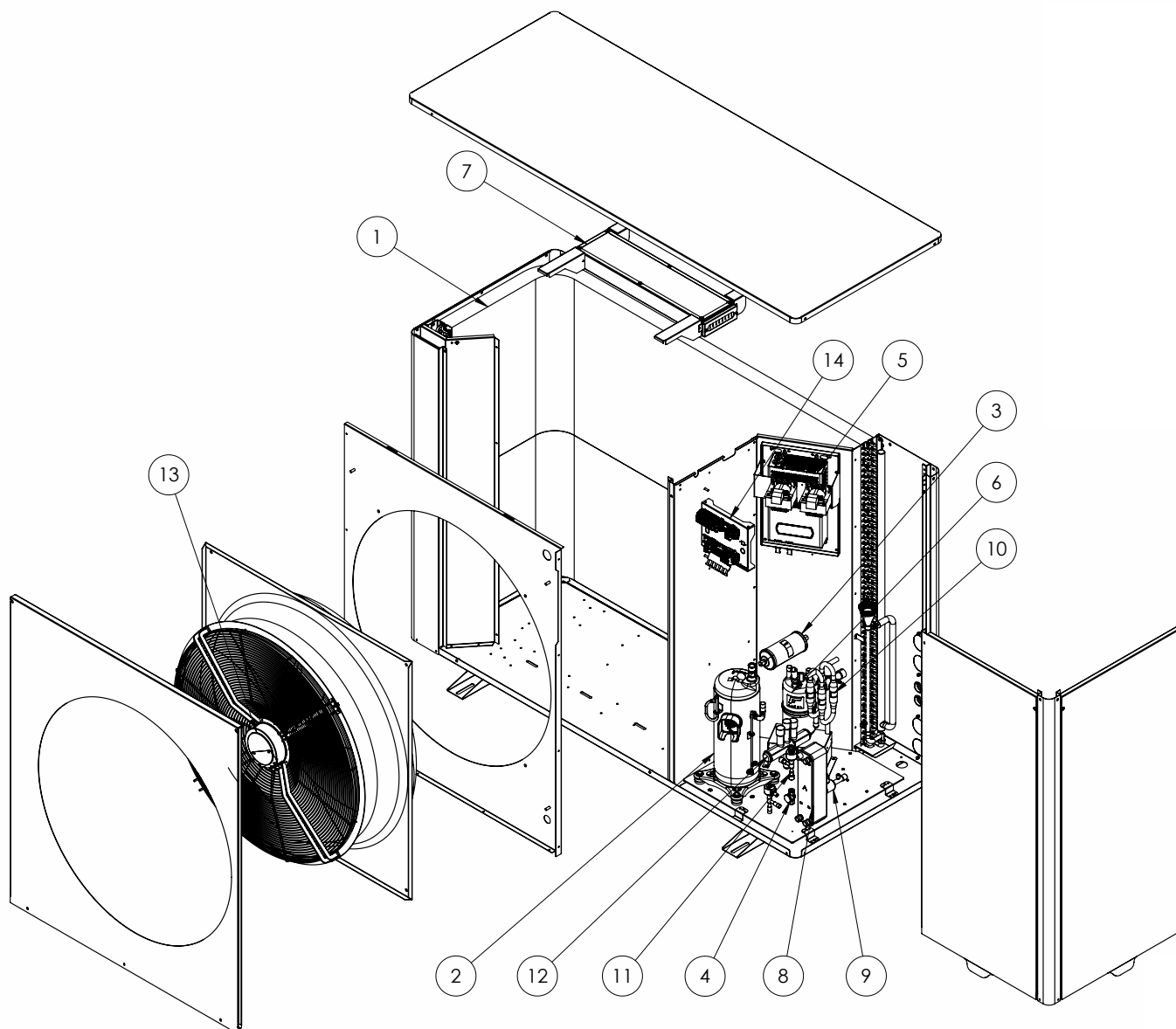

1	EVAPORATOR	9	BALL VALVES
2	COMPRESSOR	10	CHECK VALVES
3	FILTER	11	ELECTRONIC EXPANSION VALVE
4	LIQUID INDICATOR	12	4-WAY VALVE
5	INVERTER	13	FAN
6	LIQUID RECEIVER	14	SECONDARY ELECTRIC BOARD
7	ELECTRIC BOARD		
8	ECONOMIZER		

The picture has the sole purpose of indicating the main internal components. The product may not be exactly as shown in the picture.

4.7 Internal unit components diagram for Templari® KITA AIR R32/AIR COLD R32/ AIR PLUS R32 heat pump

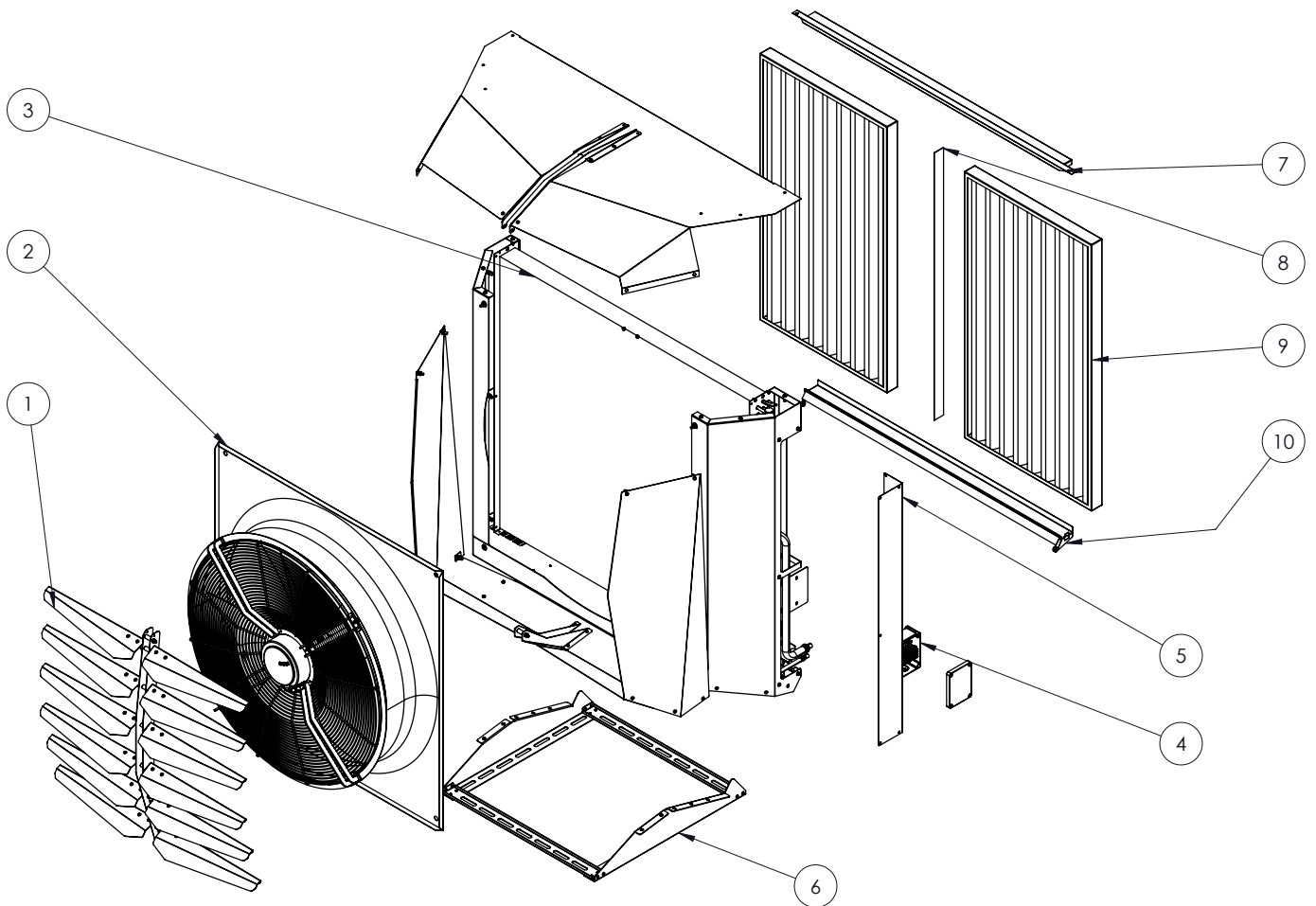

1	DEFLECTOR	8	MAGNETIC BAND
2	FAN	9	FILTER
3	EVAPORATOR	10	LOWER BRACKET
4	ELECTRIC BOARD		
5	SIDE COVER		
6	MAIN BOTTOM FRAME		
7	UPPER BRACKET		

The picture has the sole purpose of indicating the main internal components. The product may not be exactly as shown in the picture.

4.8 Internal unit components diagram (duct version) for Templari® KITA AIR R32/ AIR COLD R32/AIR PLUS R32 heat pump

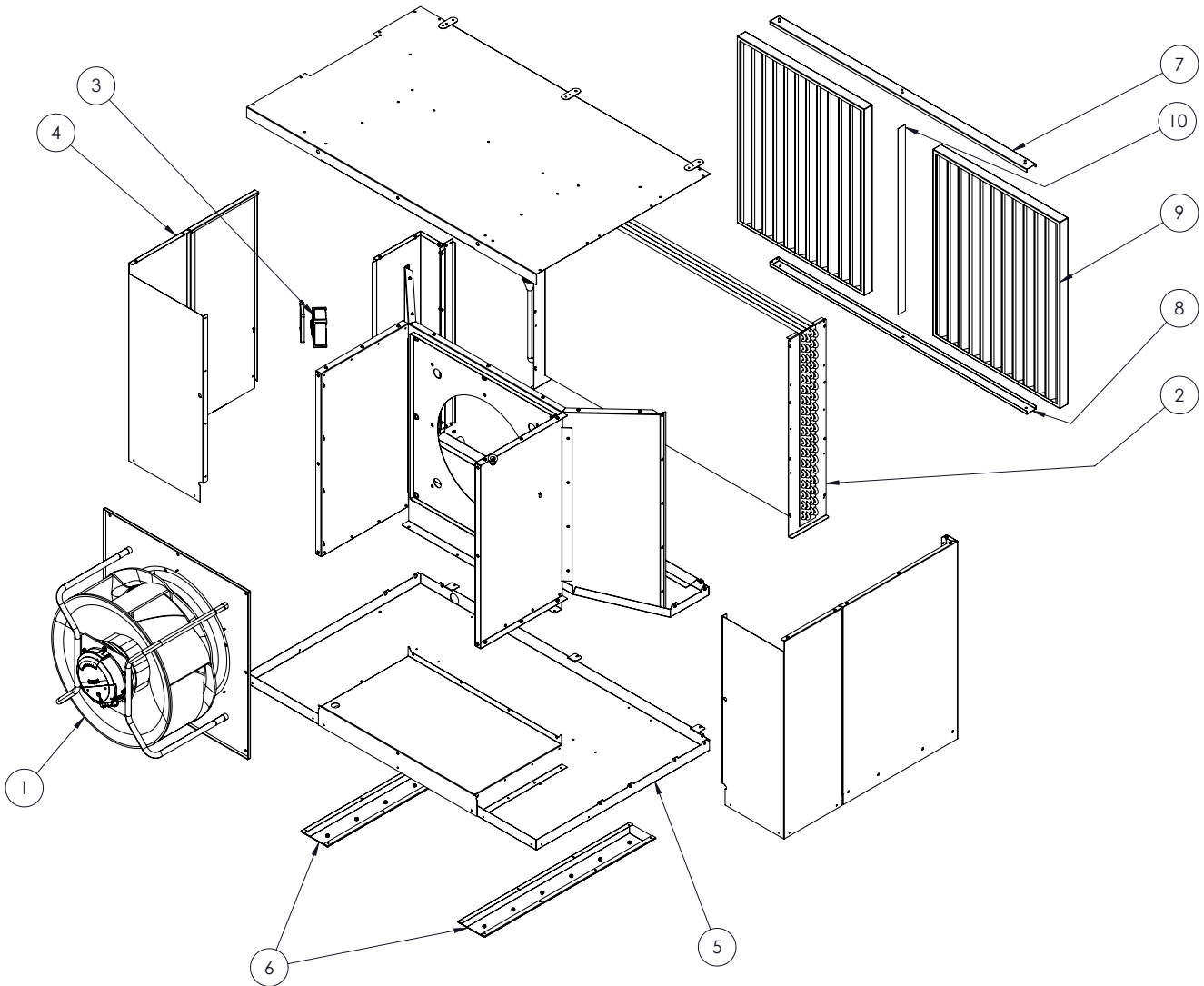

- | | | | |
|---|----------------------|----|----------------------|
| 1 | FAN | 8 | LOWER FILTER BRACKET |
| 2 | FINNED COIL | 9 | FILTER |
| 3 | ELECTRIC BOARD | 10 | MAGNETIC BAND |
| 4 | SIDE COVER | | |
| 5 | MAIN BOTTOM FRAME | | |
| 6 | BRACKETS | | |
| 7 | UPPER FILTER BRACKET | | |

The picture has the sole purpose of indicating the main internal components. The product may not be exactly as shown in the picture.

5 Transport

WARNINGS!

Regardless of the type of transport, must never be inclined more than 45°. Contrary you can have anomalies in the refrigerant circuit in the next operation. In severe cases this may have as a consequence a failure inside.

The transport to the final place of installation should be done on a pallet. The heat pump **KITA AIR Templari®** can be transported using a forklift.

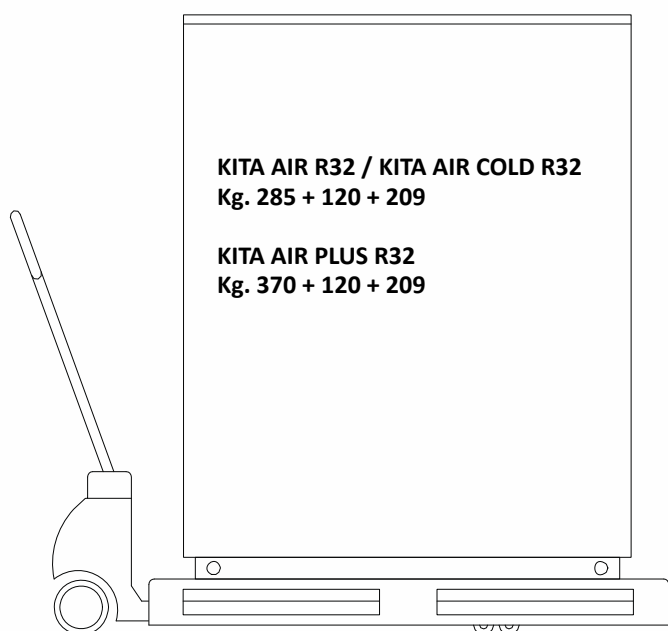

- Protect the sidewalls of the product coming into contact with the forklift to prevent scratches and damages.
- Lift the product only from the back and from the side of the fittings.
- The lifting of excessive weights can cause spinal injuries, for example.
- Consider the weight of the product reported in the technical data.
- In the transport of heavy loads, comply with the instructions and the provisions in force.
- It is recommended to pay attention do not to overexertion when lifting the internal unit. It is advisable to be at least in two persons.

6 Mounting and installation

6.1 Equipment check

- cable for remote control panel connection
- sensor probe

optional

- Anti-vibration mountings for ground fixing;
- wall support for internal unit.

6.2 External unit measurements

KITA AIR R32 / KITA AIR COLD R32

WITH LEGS

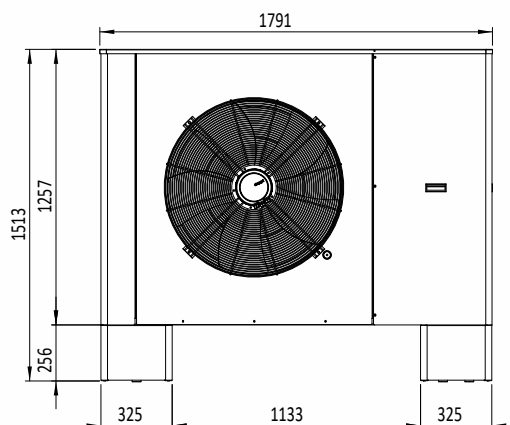
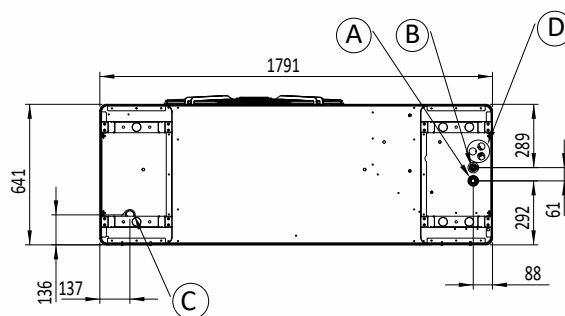

WITH BRACKETS

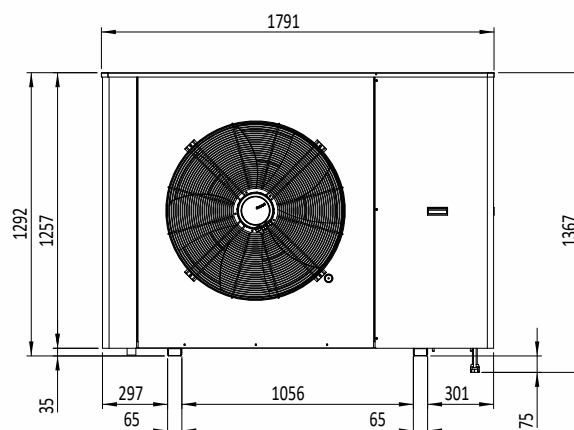
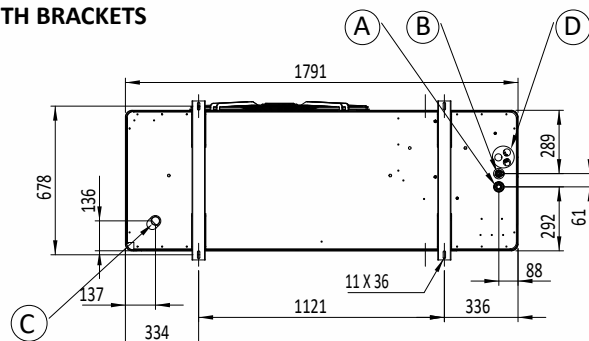

- A: gas flow / outer diameter: 22mm
- B: liquid flow outer diameter: 12mm (L42-L66 16 mm)
- C: condensate drain outer diameter: 40mm
- D: electrical wiring

KITA AIR PLUS R32

WITH BRACKETS

Bottom view

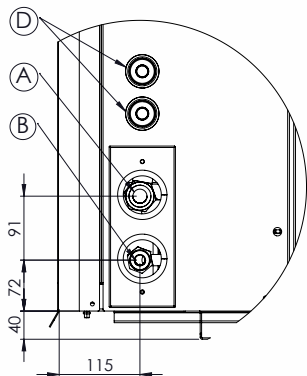
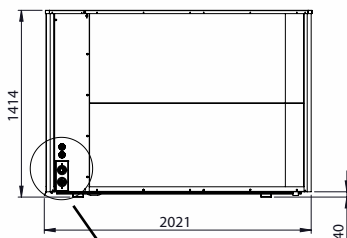
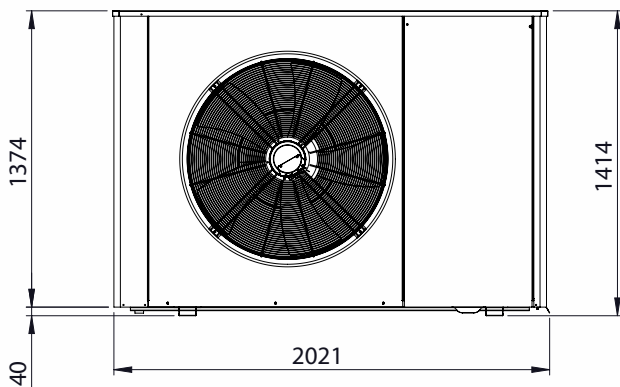
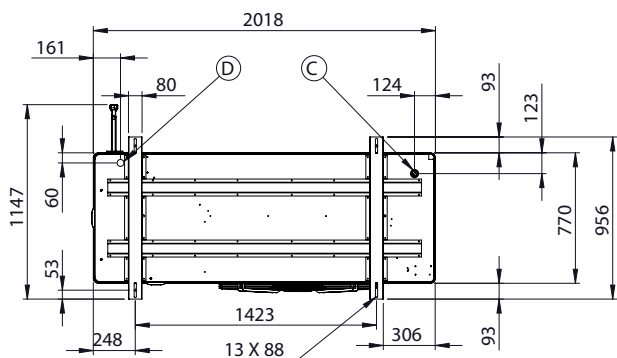

- A: gas flow / outer diameter: 28 mm
- B: liquid flow outer diameter: 16 mm
- C: condensate drain outer diameter 40 mm
- D: electrical wiring

6.3 Free spaces for the assembly

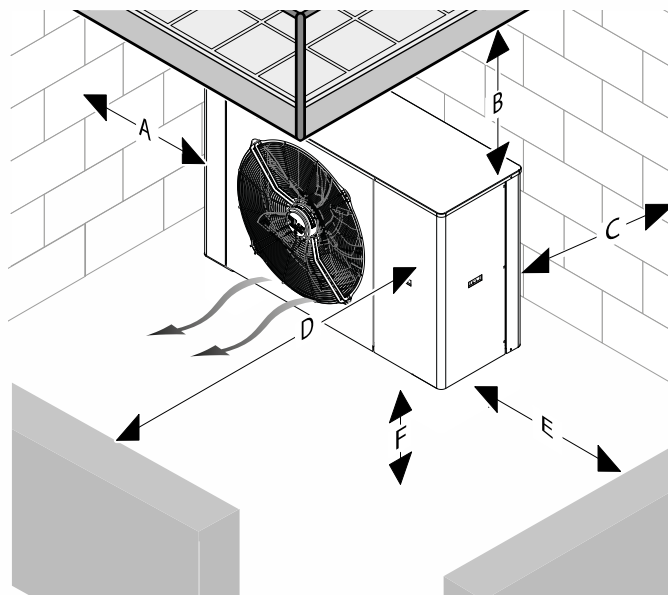

Distance	Measures in millimeters
A	>300
B	>2500
C	>500
D	>3000
E	>1000

Respect the minimum distances mentioned above to ensure a sufficient air flow and facilitate maintenance works.

- If the product is installed in areas prone to heavy snowfalls, verify the snow doesn't accumulate around the product and the minimum distances mentioned above are respected. If these conditions can't be satisfied, install then an additional heat generator in the heating circuit.

6.4 Choice of installation place

- Observe all the rules in force, included the environmental and landscape restrictions, municipal and resident regulations.
- Install the product outside the building.
- Don't install the product:
 - near a heat source,
 - near flammable substances,
 - near ventilation opening of contiguous buildings,
 - Below deciduous trees.
- For the installation of the product observe:
 - prevailing winds,
 - noise of the fan and the compressor,
 - the aesthetic impact on the building and on the surrounding environment
- Avoid the installation of the heat pump where the machine could be hit by parallel winds.
- Don't orient the fan towards the near windows.
- If necessary, install noise-protection system.
- Check if it is necessary to adopt anti-seismic criteria when installing the heat pump
- Install the product on one of the following supports:
 - Concrete pavement,
 - T steal beam
 - Concrete block.
- Don't expose the product to dusty and corrosive air (e.g. near rough roads).

- Don't install the product near wells of air discharge.
- Prepare the laying of electrical cables.
- In places where there are snowfalls, install the heat pump at least 25 cm from the ground to avoid clogging at the inlet and drain zone.

6.5 External unit mounting

1. Before installing the device, please see the safety warnings in this manual.
2. Install the product on T beam steel, Concrete Block or with a wall support.
3. Make sure that water doesn't accumulate under the device.
4. To avoid ice formation, make sure that the ground in front of the device can absorb condensed water.

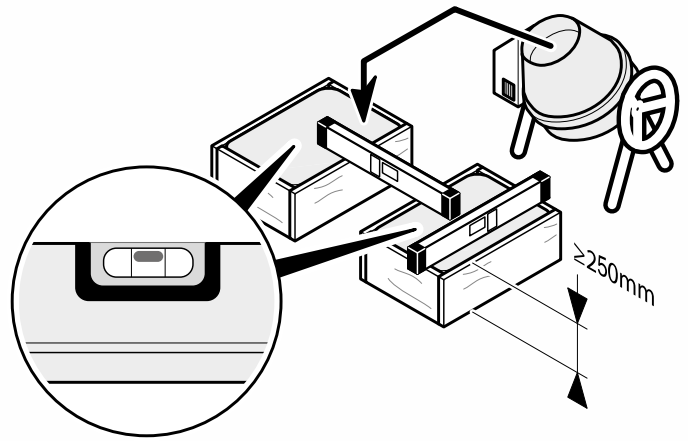

6.6 Condensate discharge preparation

The condensate is discharged behind the heat pump by a unique way. Prepare the condensate discharge with a discharge pipe or with a gravel bed.

⚠ WARNINGS!

Frozen condensate on the path can cause falls. Make sure that the condensate doesn't flow on the path and that it doesn't freeze.

- *Preparation of the base for condensate drain*

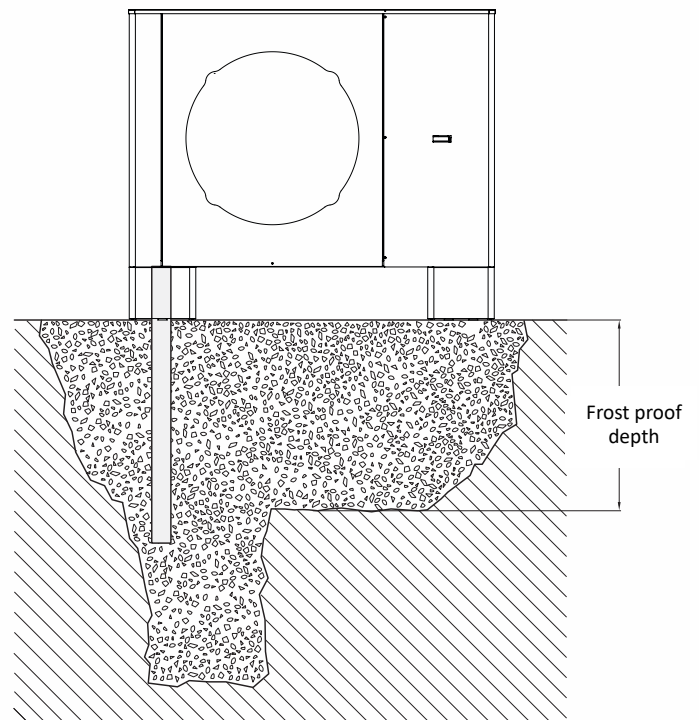
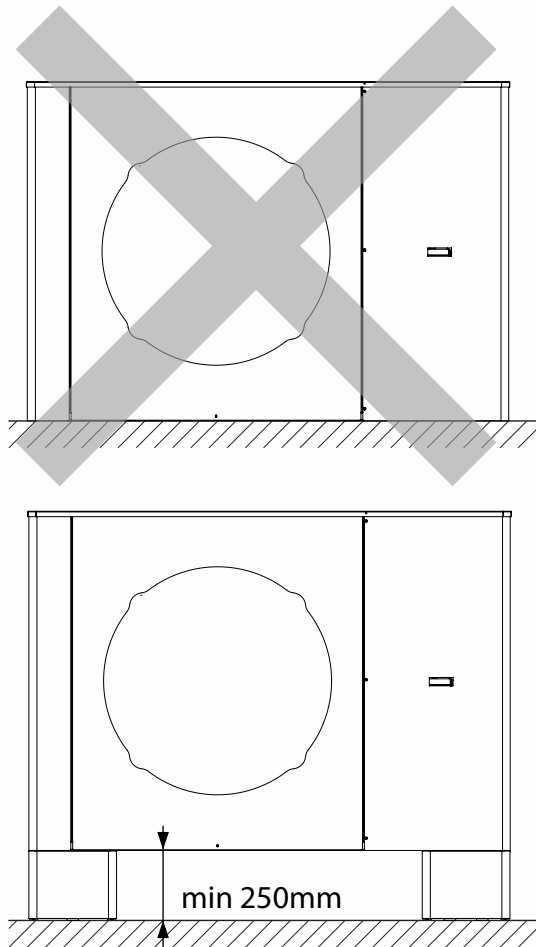

- *Example 3 condensate drain (it is recommended to bury the drain pipe to prevent the formation of ice in the event that you do not purchase optionally the heating resistor for discharge condensate)*

6.7 Correct alignment

Put horizontally the heat pump KITA AIR Templari® so that the condensate can flow. The product must be installed with amortized feet, purchased separately. The amortized feet increase the height of the product, facilitating the flow of condensate and reducing vibrations.

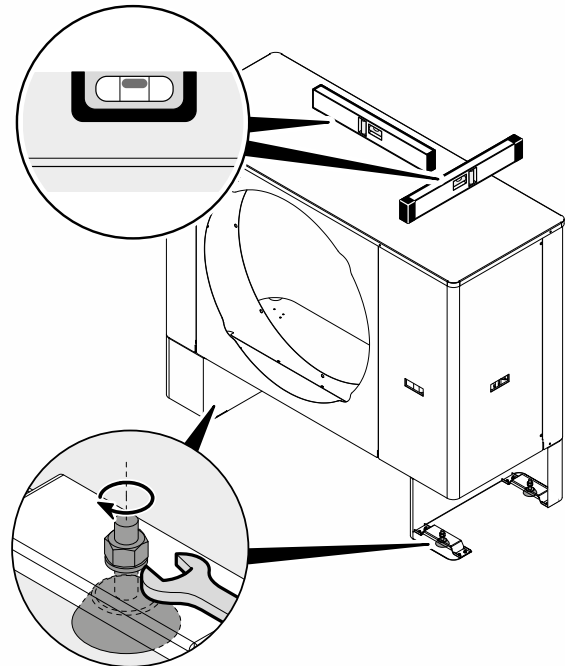
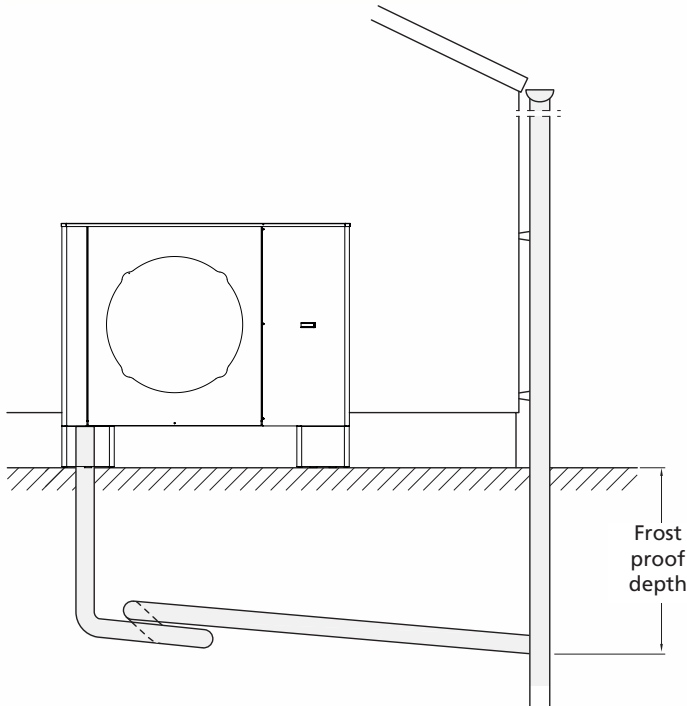

• Example 2 condensate drain

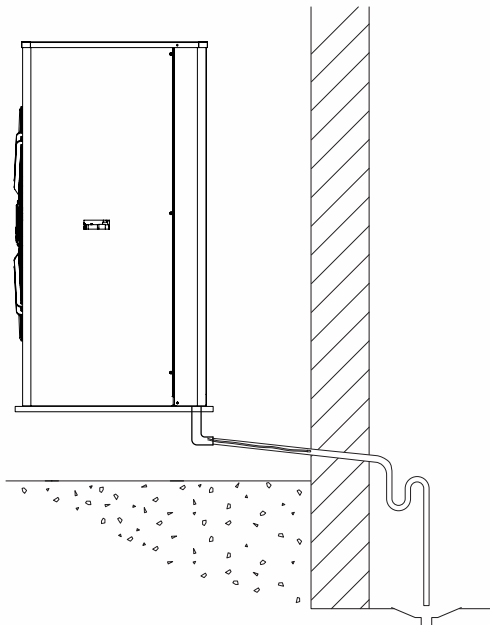

• Example 3 condensate drain with condensate drain element

The condensation water accumulated during the operation must be carried away without it can freeze. To ensure the correct outflow the heat pump must be in a horizontal position. The condensation water pipe must have a minimum diameter of 18mm and must flow in the drain channel without it can freeze. Don't discharge the condensate directly into purification basins and moats. The aggressive fumes and the condensation pipe, if it isn't protected against frost, can cause irreparable damages to the evaporator.

In places where there are snowfalls, install the heat pump at least 25 cm from the floor to avoid clogging in the suction and condensate drain area.

7 Installation and assembly of the internal unit

7.1 Internal unit sizes KITA AIR R32/KITA AIR COLD R32/AIR PLUS R32

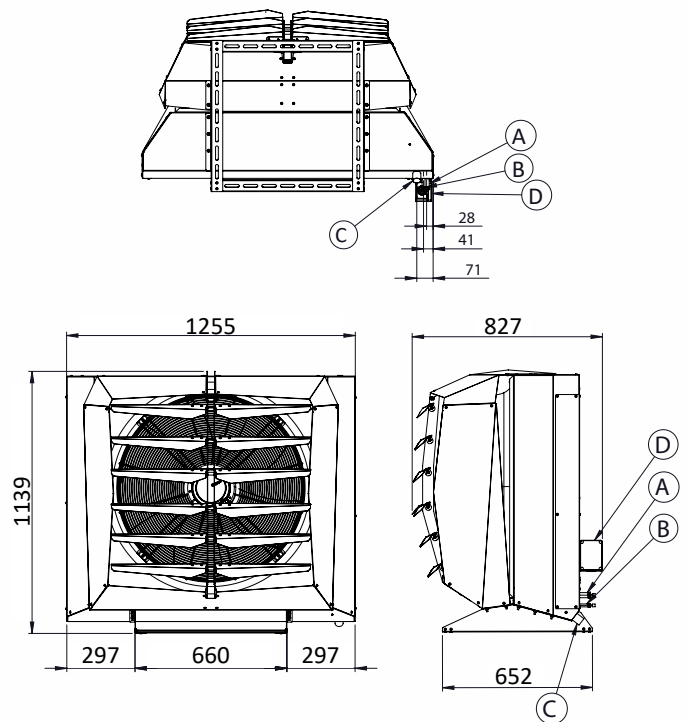

- A: gas flow / outer diameter: 22mm
- B: liquid flow / outer diameter: 12mm
- C: condensate drain / outer diameter: 32mm
- D: electrical wiring

7.2 Duct unit sizes KITA AIR R32/KITA AIR COLD R32/AIR PLUS R32

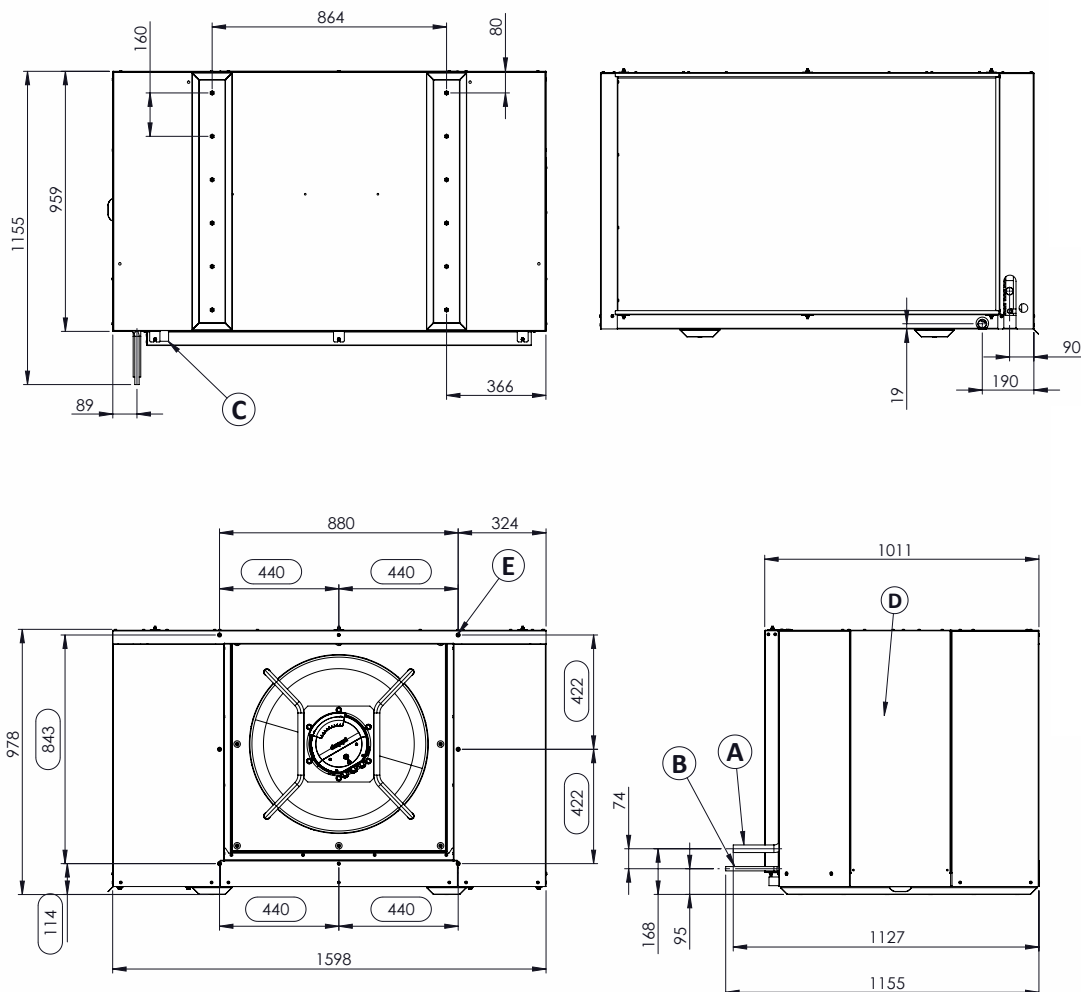

the circled dimensions are provided to install the duct adapter

- A: refrigerant passage (gas) – OD: 28 mm
- B: refrigerant passage (liquid) – OD: 16 mm
- C: condensate discharge – OD: 32 mm
- D: electric board
- E: M6 thread

7.3 Generalities and choice of the installation place

⚠ WARNING!

- Install the unit in an internal environment.
- The unit must not be install near heat or steam sources.
- Install the internal unit respecting the minimal distances from walls and obstacles for facilitate the assembly and maintenance operations.
- Secure a proper air circulation.
- Install the unit in a vertical position, as shown in figure at paragraph 7.1.

7.4 Assembly internal unit and correct positioning of B2 probe

The unit has to be fixed to the wall using dowels and L supports. Lift the unit and hang it on the wall. Caution, it is advisable to be at least in two persons or more, as the excessive weight can cause serious injuries.

The B2 probe is supplied with a 3m. prewired cable together with the internal unit

WALL CLEARANCE FOR FILTER INSTALLATION

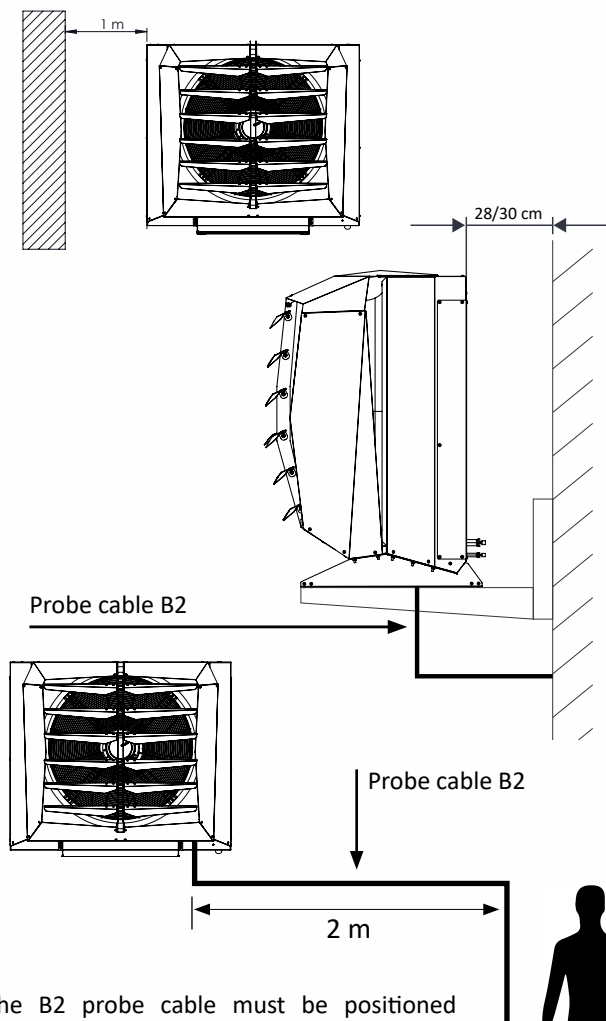

The B2 probe cable must be positioned sideways respecting a distance of 2 m from the internal unit, it must align at man height paying attention it cannot be in direct contact with the wall because it is primary that the cable of this probe be at least 3cm away from the wall.

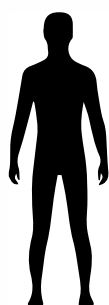

Internal unit wall installation (duct version)

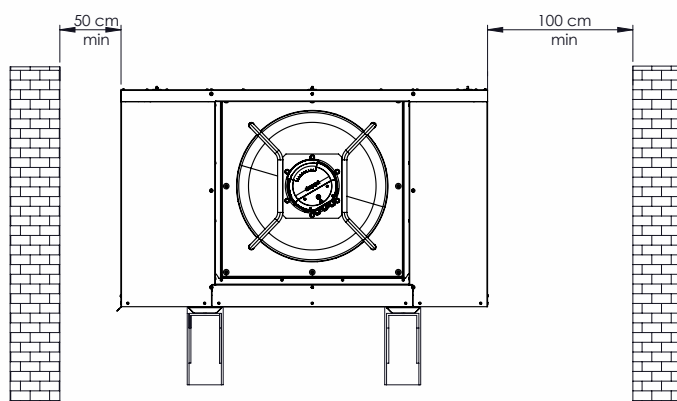
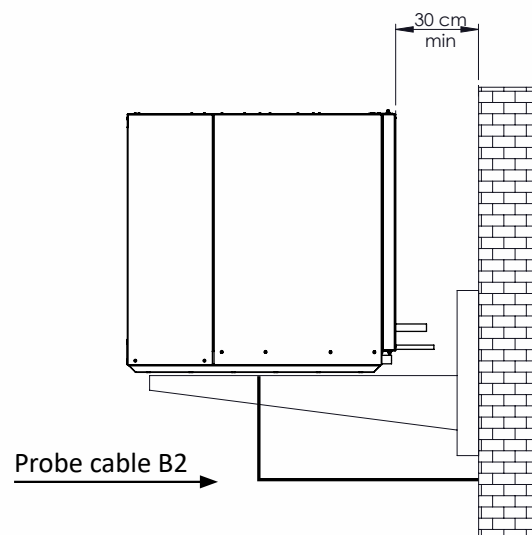

Internal unit ceiling installation (duct version)

the unit can be installed to the ceiling in two ways - with M8 threaded dowels and eyebolts (FIG. A1 - A2)

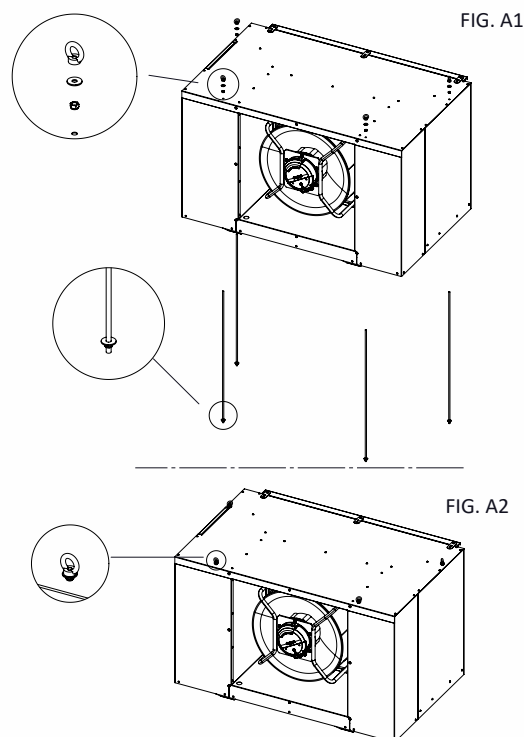

- with threaded dowels connected directly to the ceiling (FIG. B) the kits are NOT included and must be provided by the installer

Installing the internal unit filters

FILTER INSTALLATION PROCEDURE

- 1 - undo the screws on both sides of the top panel
- 2 - locate the brackets
- 3 - screw in the screws to secure the bracket to the top panel
- 4 - approach the lower bracket to the coil
- 5 - hook it onto the main bottom frame panel
- 6 - attach the magnet to the main bottom frame panel and insert it

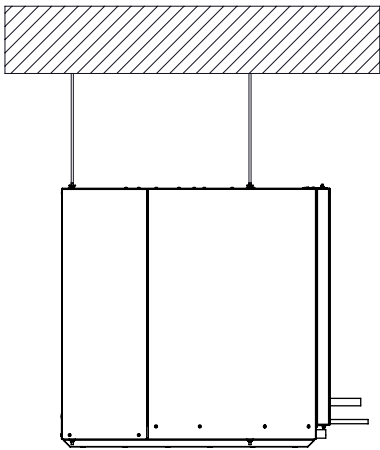
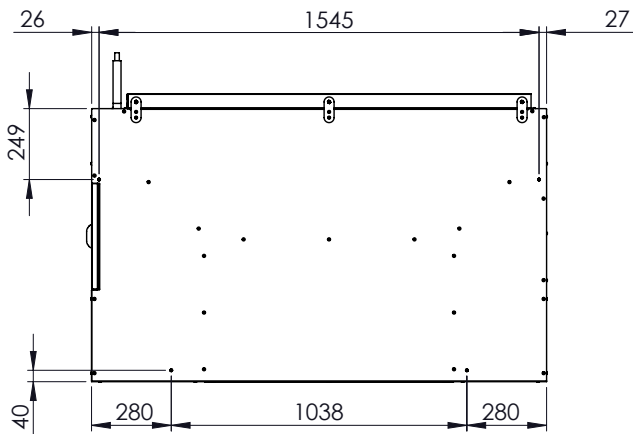
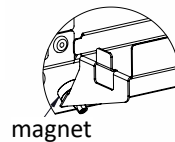
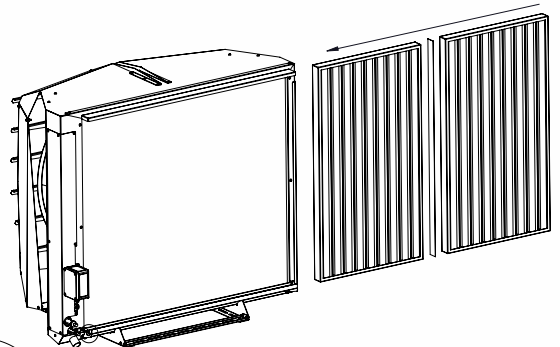
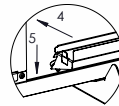
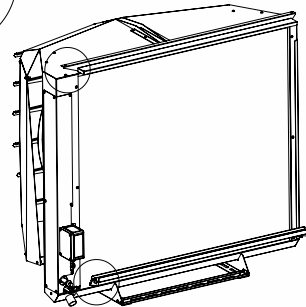
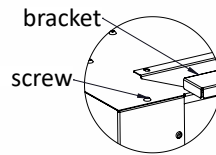

FIG. B



PLANE VIEW
drilling for M8 tie rods



Installing the internal unit filters (duct version)

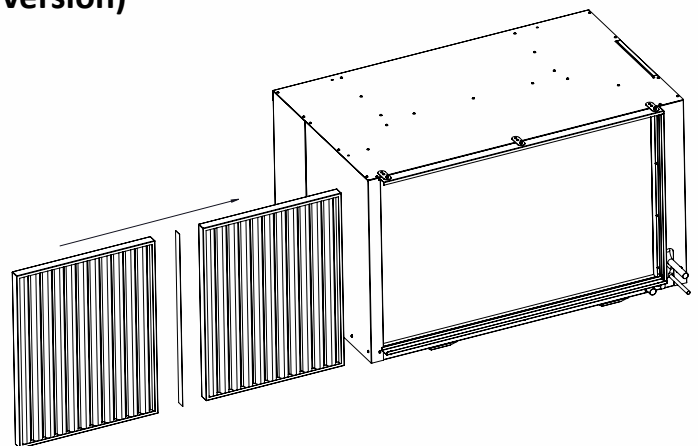

8 Refrigerant circuit connection

The refrigerant pipes connections have to be made up by qualified and licensed personnel. The connections requires the use of a weld tool.

8.1 Installation requirements

- The connecting tubes between internal and external units have to respect the below indicated dimensions.
- Non respecting of indicated measurements can lead to significant decrease of the machine performance.
- If the gap between the internal and external unit is more than 4 m, refer to the below diagram.

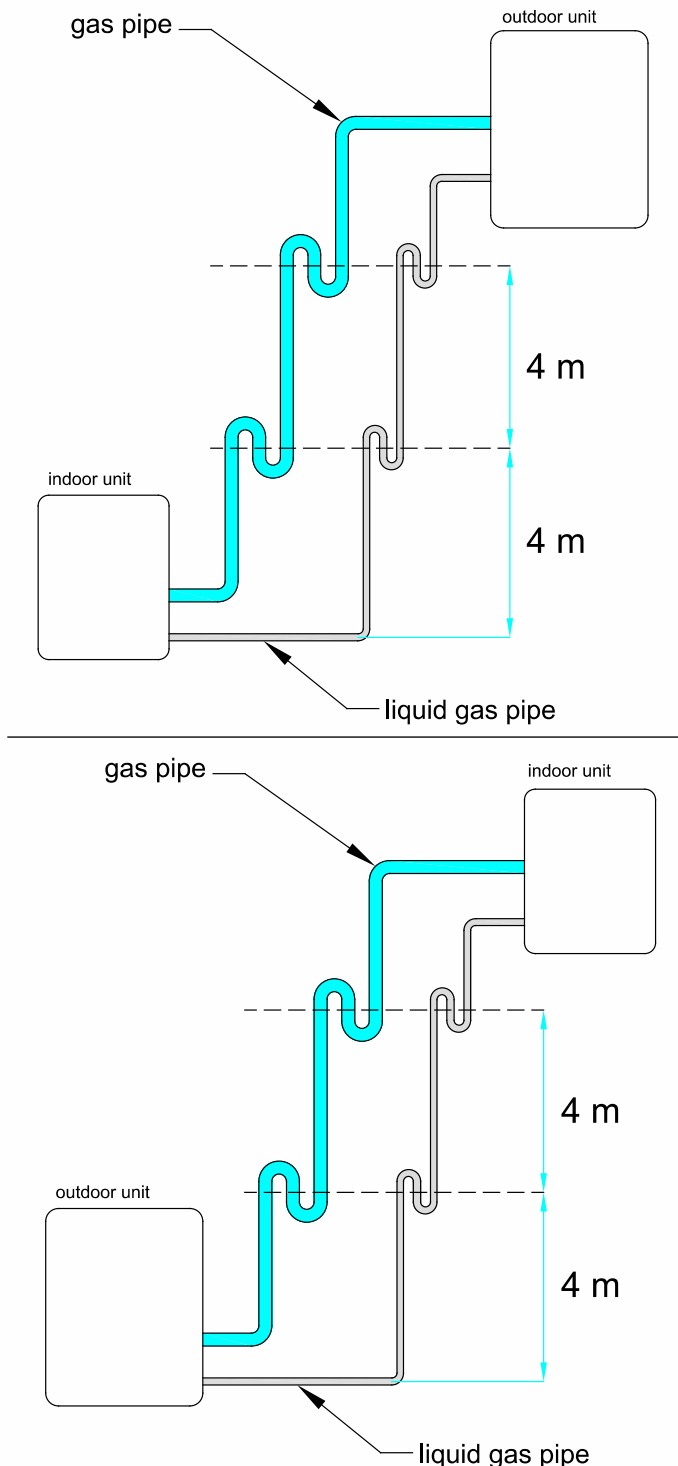

	Nominal length	Maximum length of the piping (m of equivalent length)	Maximum height difference (m of equivalent length)	Additional refrigerant charge recommended* (g/m of linear length)
AIR R32 / AIR COLD R32	1	30	30	80
AIR PLUS R32	1	30	30	80

* sub-cooling must be in a range between 3°C and 4°C with heat pump in steady state. The heat pump is pre-loaded for 10 meters of line (10m IN + 10m OUT).

Example:

For a line with 16 m $\varnothing 22$ mm gas pipes and with 16 m $\varnothing 16$ mm liquid pipes, add the following amount of refrigerant:
 $16 + 16 = 32$ meters total - (10 + 10) meters preload $\rightarrow 32 - 20 = 12 \times 80 \text{ g/m} = 960$ grams, total (0.96kg).

i NOTE!

The parameter equivalent length has to consider the curves too. Each 90° curve in the circuit has to be counted as a 1 m straight portion. Each 180° curve in the circuit has to be counted as a 2 m straight portion. Each oil trap in the circuit has to be counted as a 5 m straight portion.

8.2 Set up for installation and refrigerant pipelines installation

The coolant pipes connections must be sealed to prevent leakage of the coolant and the consequent malfunctioning of the heating pump. The connection pipes must be insulated and have diameters specified in the following table.

	Gas (mm)	Liquid (mm)
AIR R32 / AIR COLD R32	$\varnothing 22$ (7/8")	$\varnothing 16$ (5/8")
AIR PLUS R32	$\varnothing 28$ (1 1/8")	$\varnothing 16$ (5/8")

For the preparation of the pipes for installation, proceed as follows:

- Measure the distance between internal and external units, and perform all necessary installation curves..
- The laying of the pipes must include the minimum number of bends, because each curve increases the pressure drop of the circuit and reduce the machine performance.
- Cut the pipes to a length slightly greater than that measured.
- Completely remove smudging from the cut section, holding the pipe downward and blowing air into the pipe.
- Respect the safety measures that are indicated into the table, or add the request quantity of refrigerant.
- Weld the (not included) anchors at the end of the connection pipe. Weld the inner side female anchors and the outer side male anchors. Where is possible, perform welding in nitrogen atmosphere. Flow the welding with nitrogen to protect the circuit from oxidation.
- Insulate carefully the refrigerant anchors and connections. It is recommended the use of thermal insulation with a minimum thickness of 6 mm.

8.3 Vacuum procedure

- We recommend to run a leak test with nitrogen to 40 bar pressure to check the quality of the welding connections
- For the vacuum perform, connect the pump charging vacuum connection procedure (1/4) inside the external unit.
- Perform the vacuum until reaching 0.4mbr pressure (duration of procedure for about 1 h for 15m total length connection. If the length increases as result will increase duration of the vacuum perform).

- At the end of the procedure remove the pump and open the valve to pour out the refrigerant liquid.

⚠ WARNING!

it is recommended to adopt all the safety measures and use the necessary PPE while performing the above operations.

9 Maintenance and cleaning

A regularly maintenance is necessary in particular for correct and efficient heat pump operations, so as to reduce damages and usury of the components. The user decides the maintenance frequency. It depends in particular on two factors:

- The utilization mode: if the operating mode during the year is single (heat pump or chiller), an annual maintenance is suggested; if the operating mode is double (heat pump and chiller) during the year, the maintenance shall be halfyearly.
- The installation place: if the installation is located in heavy polluted places or in the presence of dust that could obstruct the finned coil, it is suggested to frequently check the finned coil conditions and, if necessary, to supply a more frequent maintenance.

⚠ WARNING!

Before carrying out any maintenance operation you must disconnect the power supply in order to avoid any injuries.

Make sure that the main switch installed near the external unit is switched off.

9.1 Finned coil cleaning

During the machine functioning it's possible that the finned battery will partially obstructed because presence of leaves or incrustations of various kinds, also provoking a malfunctioning of the heat pump. It is possible then clean the battery with a under pressure jet of air in a parallel direction of the fins, you should also remove any deposits in the battery compartment keeping an adequate distance so as not to risk to fold or damage them.

- Clean the frontal surface;
- Remove the panel on top as shown by the figure.
- clean also the internal unit finned battery, especially if it is placed in dusty ambient

⚠ WARNING!

Don't touch the fins to avoid to be cutted. Don't fold the fins, this could reduce the performances. In case of folded fins, contact a service center.

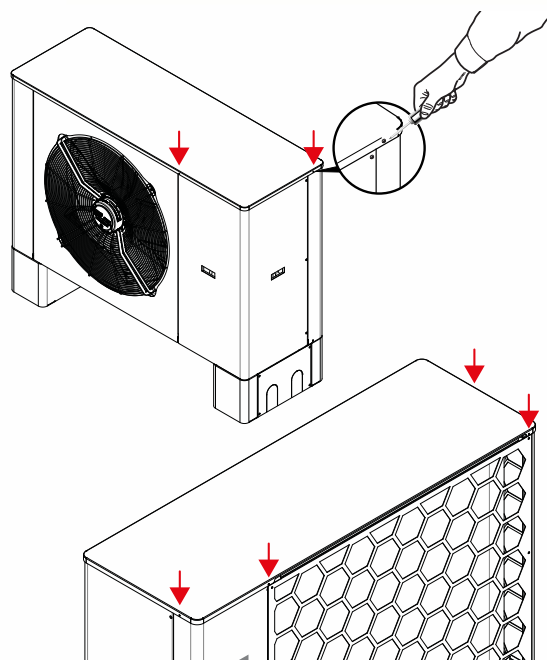

9.2 Condensate discharge cleaning

Please make sure that the condensate discharge pipe is in the correct position e without any obstruction to ensure a proper condensate flow from the finned coil fins.

9.3 Refrigerant circuit maintenance

The machine is equipped with a safety valve which ensure the reduction of internal refrigerant circuit pressure in case of external generation of heat (e.g. in case of fire).

To ensure proper operation of the valve, contact the manufacturer and make sure to replace it each 4 years.

⚠ WARNING!

The triggering of the safety valve and the consequent expulsion of the refrigerant gas may cause poisoning and injuries if in direct contact with the skin.

Do not stand or place any heat source near the safety valve.

It is necessary to empty the refrigeration circuit before performing any servicing of the heat pump that requires welding.

10 Electric connection

10.1 General information

Before starting any operation please adopt any safety device and make sure that the unit is in stable equilibrium and that there isn't any element connected to the electric supply.

It is recommended to:

- Make sure that the power line on site is compatible with the tension and absorption necessary to run the machine
- Make sure that the power supply of the heat pump (phase – neutral - ground) and the sequence of the 3 phases (L1, L2, L3) are properly wired according to the instructions.
- Make sure that upward the power supply line or the necessary safety devices (thermal breaker differential and safety switch) are properly installed according to the heat pump requirements.
- Use double insulation cables, in accordance with the existing regulations in force in the different countries.

- At first please connect the grounding connection.
- Before switching the unit on, all protections must be active.

10.1.1 The customer/ installer has to:

1. Refer to the wiring diagram of the unit
2. Supply and install the proper differential and thermal breaker, CEI approved, as close as possible to the heat pump, inside an adequate case
3. Properly install the ground connection. The manufacturer cannot be held liable for any damage caused by the improper ground connection of the appliance.
4. Evaluate the protection from indirect contacts (differential) according to the layout of the electric wiring in the installation site (see note [3]).

10.2 Operations of laying

- Please install cables far from lines with different voltage or from devices that can create electromagnetic interferences.
- Avoid parallel laying with other cables, the arrangement is only permitted at 90°
- Pass the power cables and the net control cable of the machine only through proper holes.

10.3 External unit connection

- Connect the power supply to the external unit electric terminal by the following table named "power supply cables indication". Cables passage takes place through the opposite holes.
- See 12.5 for the connection of drain pan's electric heater.

10.4 Internal unit connection

- For electric connection see the following table named "power supply cables indication". See the chapter 11 the terminal picture where to connect RS485 fan contacts (2 core cable) and the sensor probe (2 core cable). The cable carries low voltage control signals: find a route far from sources of interference, do not joints along the way, possibly using a 3 core cable + shield section 1.50 sq mm (shield connected to GND to indoor unit side).
- Connect the internal unit 230V fan power supply (phase, neutral, ground) to the terminal board of the external unit through the tripolar cable (minimum section 1,5 mmq).
- Pay special attention on ground connection: the GND must be the same for the 2 units. ABSOLUTELY AVOID THE CONTACT BETWEEN THE SIGNAL GND AND THE THE GND OF POWER SUPPLY!

WARNING!

The section of the supply cables is to be considered indicative and relative to the last part of the line towards the machine, that should be as shorter as possible. The external protections, the position and cable section of the previous supply line should be sized and realized by an authorized person and according to the technical standards of the national authorities.

10.5 Probes and control panel

The B2 temperature probe has to be installed as explained in paragraph 7.3, using the prewired cable supplied with the internal unit.

If the previously mentioned cable isn't long enough, it is possible to use a piece of multipolar cable (shielded 2x 1,5 mmq) to

extend it, following the shortest path, away from power cable and adopting all the precautions to avoid possible parasitic resistances that may interfere with the reading signal of the control board.

The B2 probe signal gets transmitted from the external unit to the internal one by a bipolar cable.

The control panel gets connected to the external unit by a 6 metres telephonic cable supplied with the heat pump (on demand up to 30 m), to be laid together with the B2 probe signal cable using the same precautions.

10.6 Power supplying

Connect the power supply to the internal terminal block as indicated in the diagram below.

Use the specific wire holes to pass the cable through.

INFORMATION AND CHARACTERISTICS OF THE PROTECTION DEVICES AND SIZING OF THE CABLES.

MODEL	Nominal power	Tension (V)	Inverter	Power supply connection	Thermal breaker ^[1]	Section of the connection cable ^[2]	Main thermal breaker ^[3]
AIR R32	14,2 kW	400	24/27/30 A	3P+N+T	4x25A	5G4	4x25A
AIR COLD R32	16 kW	400	35/38 A	3P+N+T	4x32A	5G6	4x32A
AIR PLUS R32	18 kW	400	38/40/45 A	3P+N+T	4x32A	5G6	4x32A

[3] Templari devices are tested with Schneider class A residual current circuit breakers. Full compatibility is not guaranteed if other makes of residual current circuit breaker are applied.

10.6.1 Internal unit auxiliary heater (optional)

If an auxiliary heating element kit is installed it will be necessary to arrange a dedicated power supply line with a 3-PH 400VAC thermal breaker for the 9 Kw version or a 400 V 25 A thermal breaker for the 13.5 Kw version.

The power supply line will also have to be equipped with a 3-PH 400 VAC (Idn30mA) circuit breaker.

If the power supply line comes straight from the external unit terminal board it will be necessary to install a proper thermal breaker upward the external unit. The thermal breaker must be properly sized according to the above chart and be able to supply the total of the current absorbed by the heat pump and the internal unit auxiliary heater.

The external unit also in this case will require a 3-PH 400V 30mA circuit breaker.

The installation of the correct safety devices and electric line must be carried out according to the existing regulations in force in the different countries.

NOTE!

[1]

In the above chart it is indicated the characteristics of the thermal breaker that must be installed as close as possible to the external unit. The installation of this device is required to protect the terminal part of the supplying line from overcurrent and short circuit.

[2]

The section of the power cable is to be considered approximative and referred to the terminal part of the line toward the heat pump (must be as short as possible). The previously mentioned section is to be considered for a maximum length of 5m.

If the length of the cable is more than 5 m. (or for different type of cables) the authorized technician must size properly the main switch, the power line, the connection of the ground protection and connection cables according to: the installation site, environment temperature, length, type of cable and power absorption of the unit.

[3]

The siting, choice and the check-up of the protection devices upward the heat pump must be carried out only by authorized and qualified technicians as provided for by the current legislation of the origin country.

Moreover a preliminary check, necessary for the installation of the protection devices against the indirect contacts, must be carried out.

This is the reason why it is mandatory to install class "A" differential blocks with $I_{dn} = 30$ mA.

It is also possible to combine a differential block for the protection from indirect contact to the thermal breaker.

WARNING!

The characteristics of the power supplying/ signal cables of the chart above must be verified according to the current legislation.

10.7 Power and signal cables characteristics

EXTERNAL UNIT	
Power supply connection from main electric panel	3P+N+T - 400 Vac - 50 Hz
Power supply cable from main circuit breaker to external unit (set up by the customer/installer)	SEE CHART Maximum length 5 meters
400 Vac line internal safety device	3 fuses da 5x20 - 4A
24 Vdc internal safety device	1 fuses da 5x20 - 4A

INTERNAL UNIT	
Power supply line from external unit	2P+T 230 Vac 50 Hz 3P+N+T 400 Vac 50 Hz
Power supply cable (set up by the customer/installer)	Minimum section 3x1,5 mmq Maximum length 30 meters
Signal cable from external unit to internal unit (set up by the customer/installer; ON DEMAND: supplied together with the heat pump)	Bipolar, RS485 Modbus RTU
B2 probe extension cable from internal unit to external unit. (set up by the customer/installer) (f.p.o. a cura Cliente/Installatore)	Bipolar

CONTROL PANEL	
Signal cable for standard panel to be connected to the external unit main board (supplied together with the heat pump, L=6 m; ON DEMAND: L up to 30 m)	Telephone cable
Signal cable for touch screen panel to be connected to the external unit main board	Bipolar, RS485 Modbus RTU

10.8 User electrical panel with μ PC control board

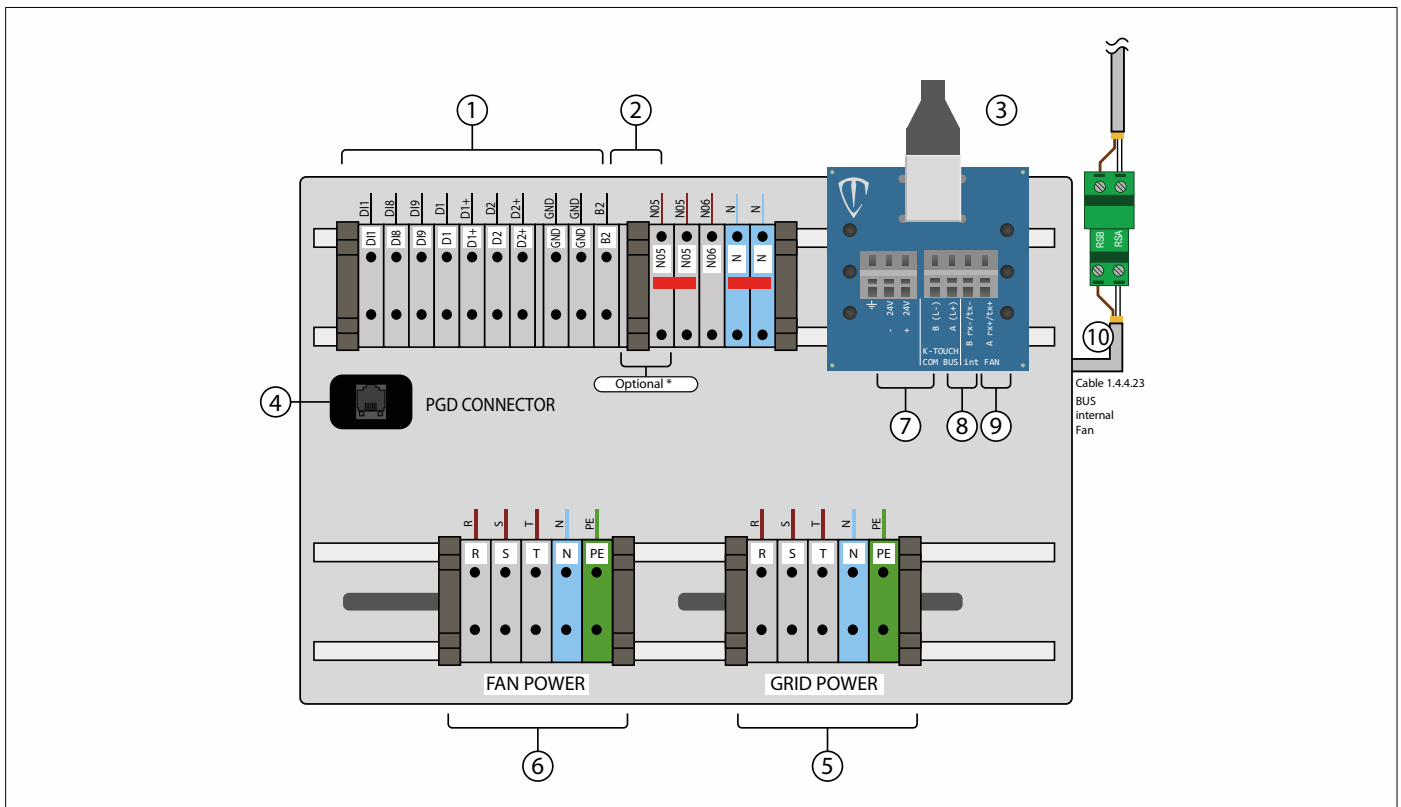

FIG. 1 User electrical panel with μ PC control board

Ref.	Function	Ref.	Function
1	Digital contact block	GND	Ground terminal
2	Auxiliary heater control terminal block (optional)	DI1	Summer-winter switch
3	BUS connection and power supply to the main electrical panel	DI8	Remote On-Off
4	PGD connector	DI9	MODBUS controller switch
5	Heat pump main power 3-PH or 1-PH [GRID POWER]	R	Phase 1
6	Internal unit fan power terminal block 3-PH or 1-PH [FAN POWER]	S	Phase 2
7	24 Vdc power and ground terminal for power to K-Touch and BUS cable shield for K-Touch panel	T	Phase 3
8	BUS cable connection for K-Touch panel	N	Neutral
9*	BUS cable connection for internal unit		Ground terminal for K-Touch panel BUS cable shield
10*	BUS cable connection for the indoor unit. Use this as an alternative to connection point 9	+ 24V	+Vdc terminal for K-Touch panel power
24V	24 Vdc power for K-Touch operator panel	- 24V	0 V terminal for K-Touch panel power
D1	SG1 no-voltage contact return	L+	A terminal for K-Touch panel communications BUS
+D1	SG1 no-voltage contact power	L-	B terminal for K-Touch panel communications BUS
D2	SG2 no-voltage contact return	rx+/tx+	rx+/tx+ terminal for internal unit communications BUS
+D2	SG2 no-voltage contact power	rx-/tx-	rx-/tx- terminal for internal unit communications BUS

*If a 2-pole plug-in terminal (10) is present, use it instead of the terminals indicated in point 9 to connect the communication bus between the indoor and outdoor units

TAB. 1 (Secondary electric board terminal block – K-Touch panel connection)

10.9 User electrical panel with μ kita control board

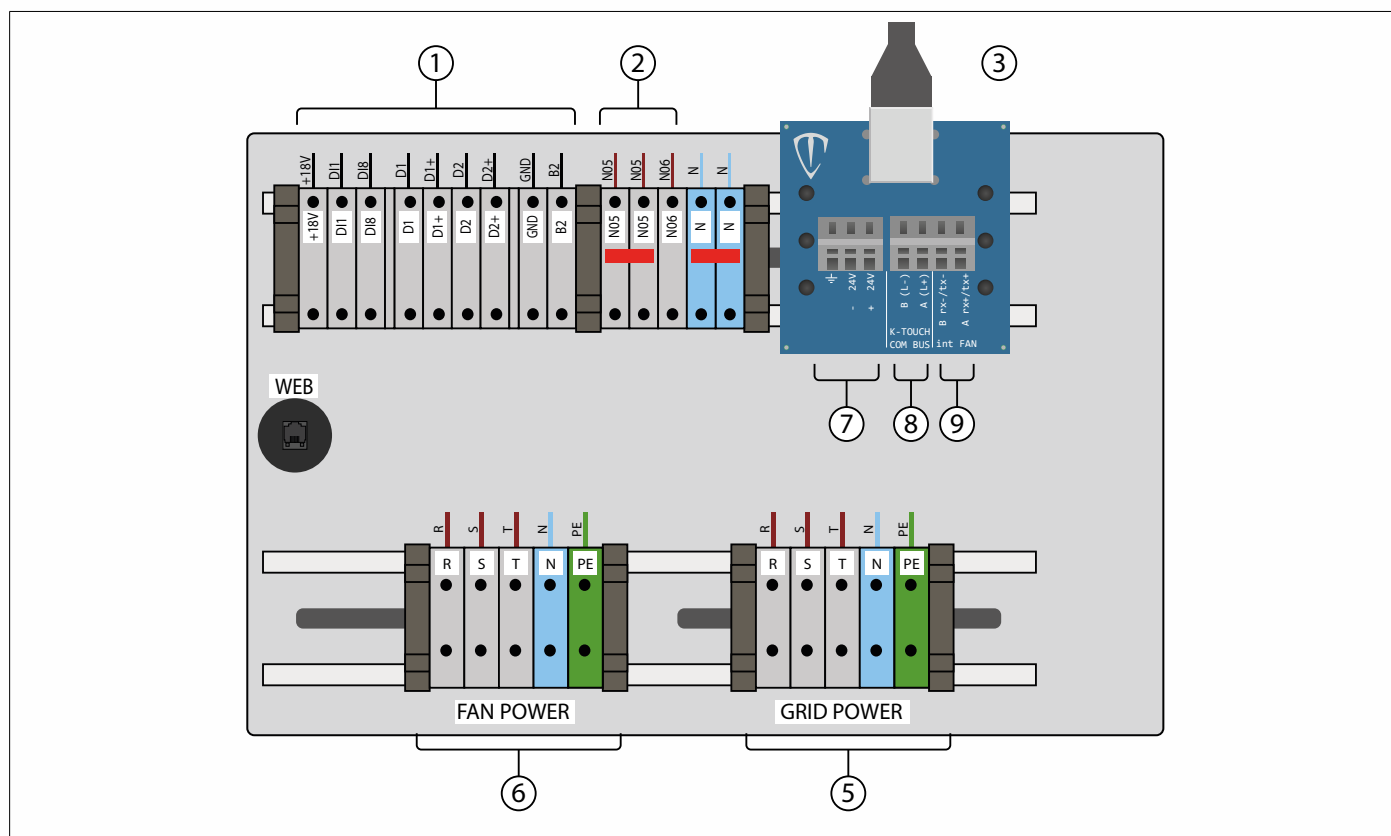

FIG. 2 User electrical panel with μ kita control board

Ref.	Function	Ref.	Function
1	Digital contacts and B2 probe terminal block	DI1	Summer-winter switch
2	Auxiliary heater control for indoor unit (N06) and condensate drain heater (N05) (optional)	DI8	Remote On-Off
3	BUS connection and power supply to the main electrical panel	R	Phase 1
4	PGD connector	S	Phase 2
5	Heat pump main power 3-PH or 1-PH [GRID POWER]	T	Phase 3
6	Internal unit fan power terminal block 3-PH or 1-PH [FAN POWER]	N	Neutral
7	24 Vdc power and ground terminal for power to K-Touch and BUS cable shield for K-Touch panel		Ground terminal for K-Touch panel BUS cable shield
8	BUS cable connection for K-Touch panel	+ 24V	+Vdc terminal for K-Touch panel power
9	BUS cable connection for internal unit	- 24V	0 V terminal for K-Touch panel power
24V	24 Vdc power for K-Touch operator panel	A (L+)	A terminal for K-Touch panel communications BUS
D1	SG1 no-voltage contact return	L- (B)	B terminal for K-Touch panel communications BUS
D1+	SG1 no-voltage contact power	rx+/tx+	rx+/tx+ terminal for internal unit communications BUS
D2	SG2 no-voltage contact return	rx-/tx-	rx-/tx- terminal for internal unit communications BUS
D2+	SG2 no-voltage contact power	WEB	Internet connection for the outdoor unit (mandatory)
GND	Ground terminal		

TAB. 2 (Secondary electric board terminal block – K-Touch panel connection)

10.10 Internal unit terminal block

⚠ WARNING!

The internal unit fan power **MUST** be connected to the terminal block inside the external unit user panel, as shown in figure 1, section 10.8.

The fan power may be 1-PH or 3-PH, depending on the model of internal unit.

Auxiliary heater (optional)

See also section 10.6.1 Auxiliary heater on internal unit (optional)

If the internal unit has an auxiliary heater, the latter's power line must be provided and dimensioned by the installer or plant designer to handle to the auxiliary heater's power draw.

The auxiliary heater power line must be connected directly to the building electrical system or to an electrical panel equipped with the appropriate electrical safety equipment, as required by local regulations.

DO NOT CONNECT the auxiliary heater power line to the external unit's user panel terminal block.

Internal unit terminal block 3-PH

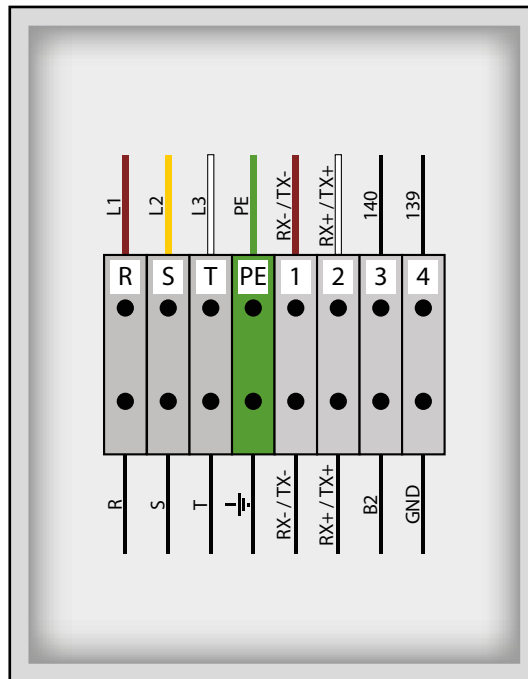

FIG. 3 Internal unit terminal block 3-PH

Internal unit terminal block with auxiliary heater

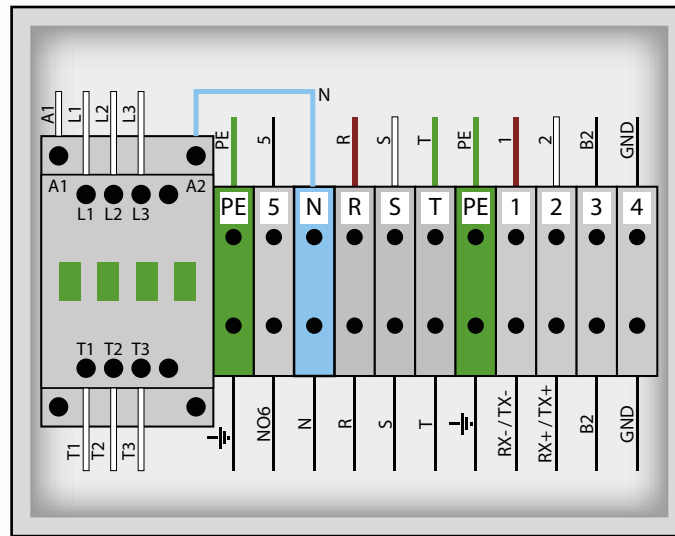

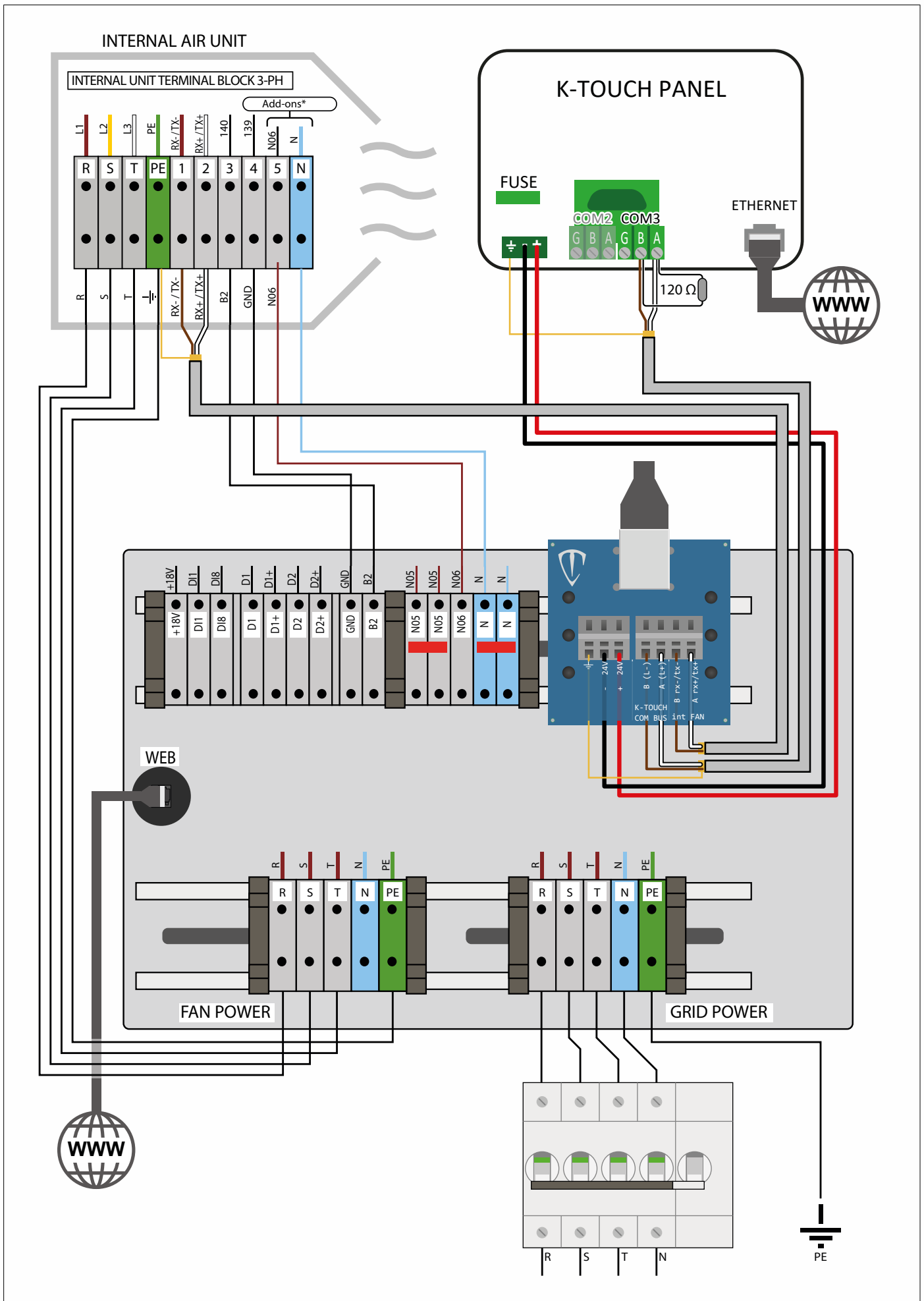

FIG. 4 Internal unit terminal block 3-PH, with auxiliary heater

Ref.	Function	Ref.	Function
	Ground terminal	- 24 V	GND terminal for K-Touch panel power
R	Phase 1	rx+/tx+	rx+/tx+ terminal for internal unit communications BUS
S	Phase 2	rx-/tx-	rx-/tx- terminal for internal unit communications BUS
T	Phase 3	B2	B2 ambient probe signal
N	Neutral	GND	B2 ambient probe ground
+ 24 V	+Vdc terminal for K-Touch panel power	G06	Auxiliary heater control

TAB. 3 (Secondary electric board terminal block – K-Touch panel connection)

10.12 Indoor unit–outdoor unit connection for heat pumps with μ Kita control board



10.13 K-Touch operator panel connection

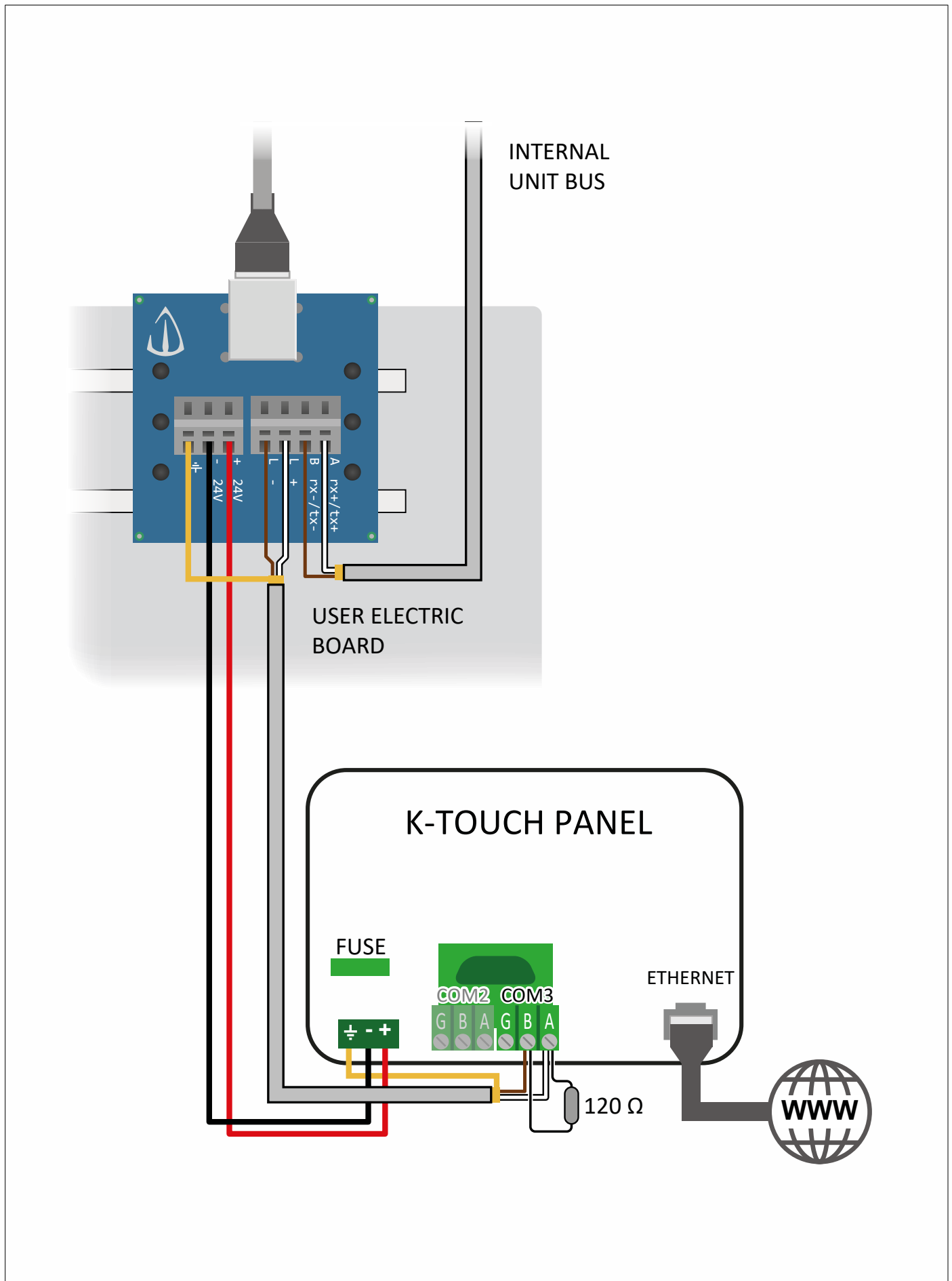

FIG. 5 K-Touch panel connection

11 K-TOUCH user panel

11.1 Warnings

To enable remote control and proper servicing (by a qualified technician), the K-Touch control panel must be connected to a router or network switch with active network connection. If a firewall is running, network traffic through the respective connection ports must be enabled. Refer to the table to check the network connection settings:

TCP ports	Enabled incoming servers
8000	auth.ihmi.net (54.238.174.31:443)
20248	
5900	account.ihmi.net (54.171.161.211:443)
80	
5800	www.weincloud.net (52,211,224,169:443)
2000	
8005	ireland.wvpn.ihmi.net (34.253.91.245:443)
8001	
21	japan.wvpn.ihmi.net (13.114.36.115:443)
443	
8010	us.wvpn.ihmi.net (13.56.221.131:443)
10463	

The panel is provided with the Easy Access service enabled. This enables the panel to be accessed with a PC or smartphone running an appropriate client. The access credentials are emailed to the client at the time of activation. This is why you must provide a valid email address when purchasing the equipment, so that Templari S.p.A. can send you the necessary information and receive the service activation form once it has been completed and signed by the end user.

11.2 K-Touch panel, electrical connections

i NOTE!

The K-Touch panel may only be powered by the machine's internal power line, on pain of voiding the warranty.

! WARNING!

We recommend using an HCC CABLE data cable, available on request.

The heat pump must be hooked up to the K-Touch panel as shown in section 10.11.

MODBUS cable type: Templari HCC cable (type: Belden 3105A 2x22AWG shielded)

Power cable type: 2x1 mm2

Prepare the electrical system for the routing of cable duct measuring at least 16 mm in diameter to contain the BUS cable and power alone.

BUS and 24 Vdc power connection between the heat pump and the K-Touch

Connect the ground terminal to the BUS data cable shielding braid.

The braids of the various sections of cable between the peripherals must be connected in series and NOT inserted into the G terminal of each peripheral, as in the Multi-Air figure in par. 14.1.

Installation notes:

If installing multiple peripherals or heat pumps, the BUS data cables must NOT be connected with direct branches forming Y or star connections.

The connection between successive peripherals must be made by chaining them, with the BUS peripherals connected in sequence.

Connecting to the internet for remote connection

To use the K-Touch remotely with a VNC program, connect the RJ45 port (LAN1) on the back of the K-Touch panel to a router or switch with an Ethernet cable. When first booting up the system, check that the remote control is working properly and that the communications ports indicated in the table are enabled.

! WARNING!

The BUS network must be equipped with a 120 Ω termination resistor between terminals A and B of the peripherals at the ends of the network. For an installation composed of a heat pump and its K-Touch control panel, make sure that the termination resistor bridges the A and B terminals of the K-Connect board in the K-Touch panel, as shown in the figure.

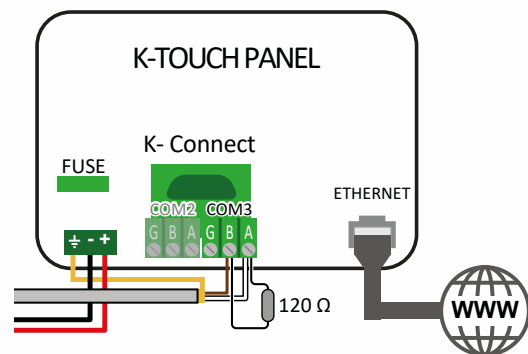

11.3 Connection to the heat pump and simultaneous PGD use - only for heat pumps with μPC control board

Hook the K-Touch panel up to the heat pump as shown in figure 4, par. 10.11. If you want to use the PGD1 remote control panel at the same time as the K-Touch panel, you **must** use a **BMS** board (available separately).

Make the connection as shown in figure 5, par. 11.3 (K-Touch panel connection via BMS).

If the heat pump and K-Touch panel are not communicating, you may need to check the connections of the communications terminals on the electric board and μPC controller (see the wiring diagram in par. 16.1).

If a BMS board has been installed, check that a 120 Ω resistor has been installed at both ends of the BUS connection.

For the K-Touch panel to work properly, set the communications

protocol to MODBUS SLAVE on the PGD1 panel (screen Ge01).

For the μ PC, make sure you have **NOT** connected terminal ID09 to GND.

This configuration enables the PGD1 control panel and K-Touch panel to be used at the same time.

If the K-Touch panel is the only available display, and it is connected to the heat pump via the P-LAN port, then contact ID9 on the μ PC board must be connected to GND as shown in figure 6, par. 11.3 (K-Touch panel connection via P-LAN).

K-Touch panel connected via BMS

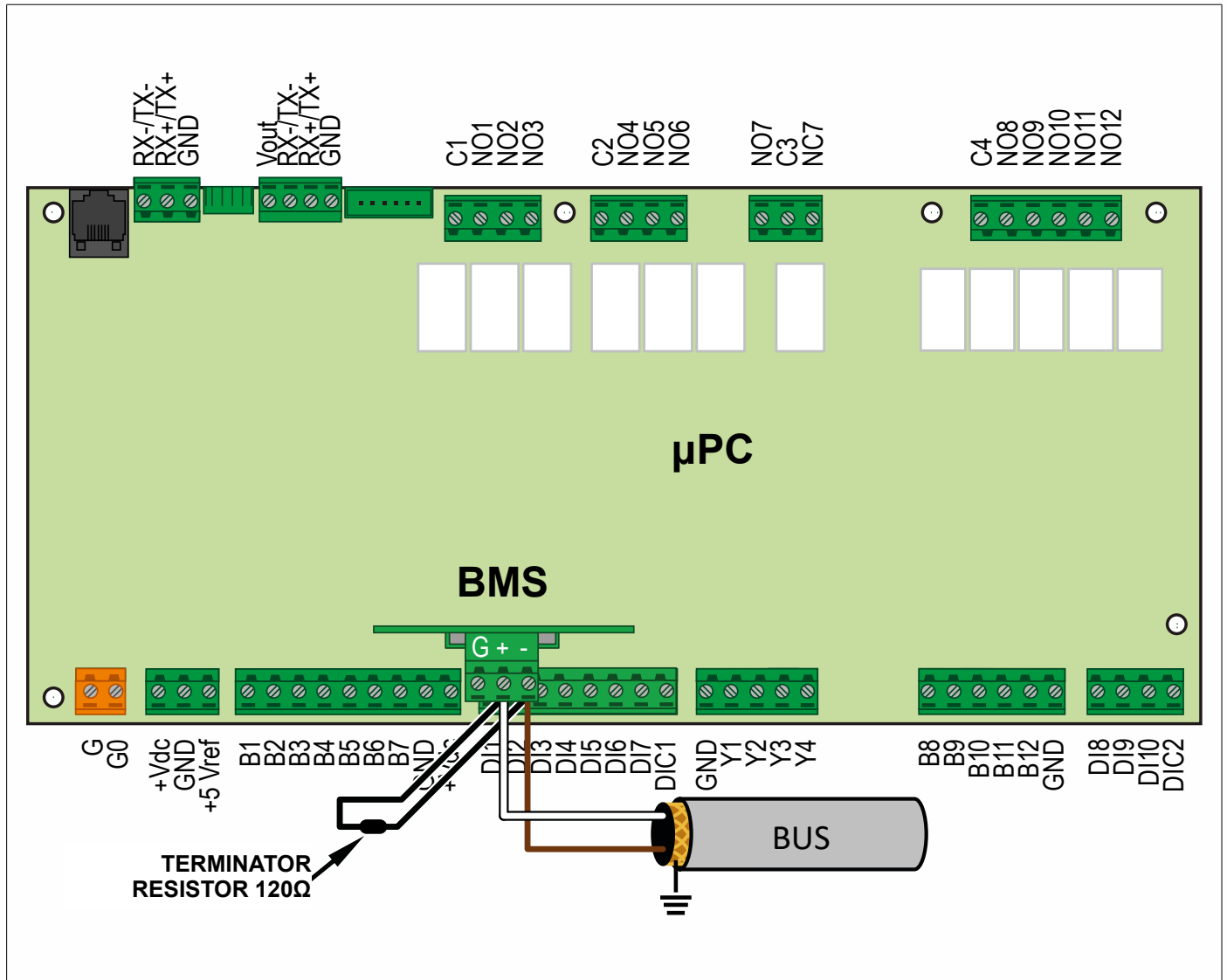

FIG. 6

K-Touch panel connected via P-LAN as the only display

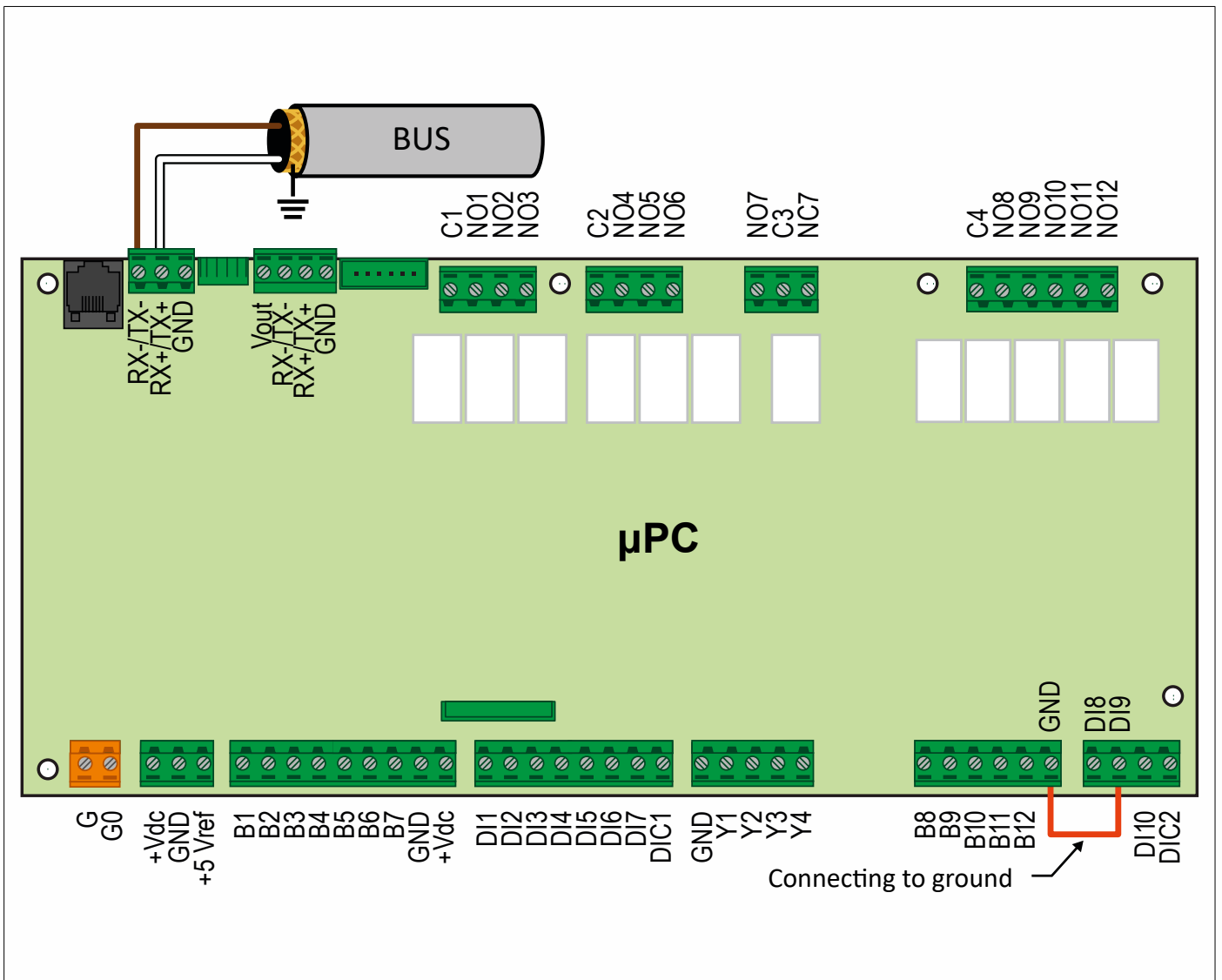
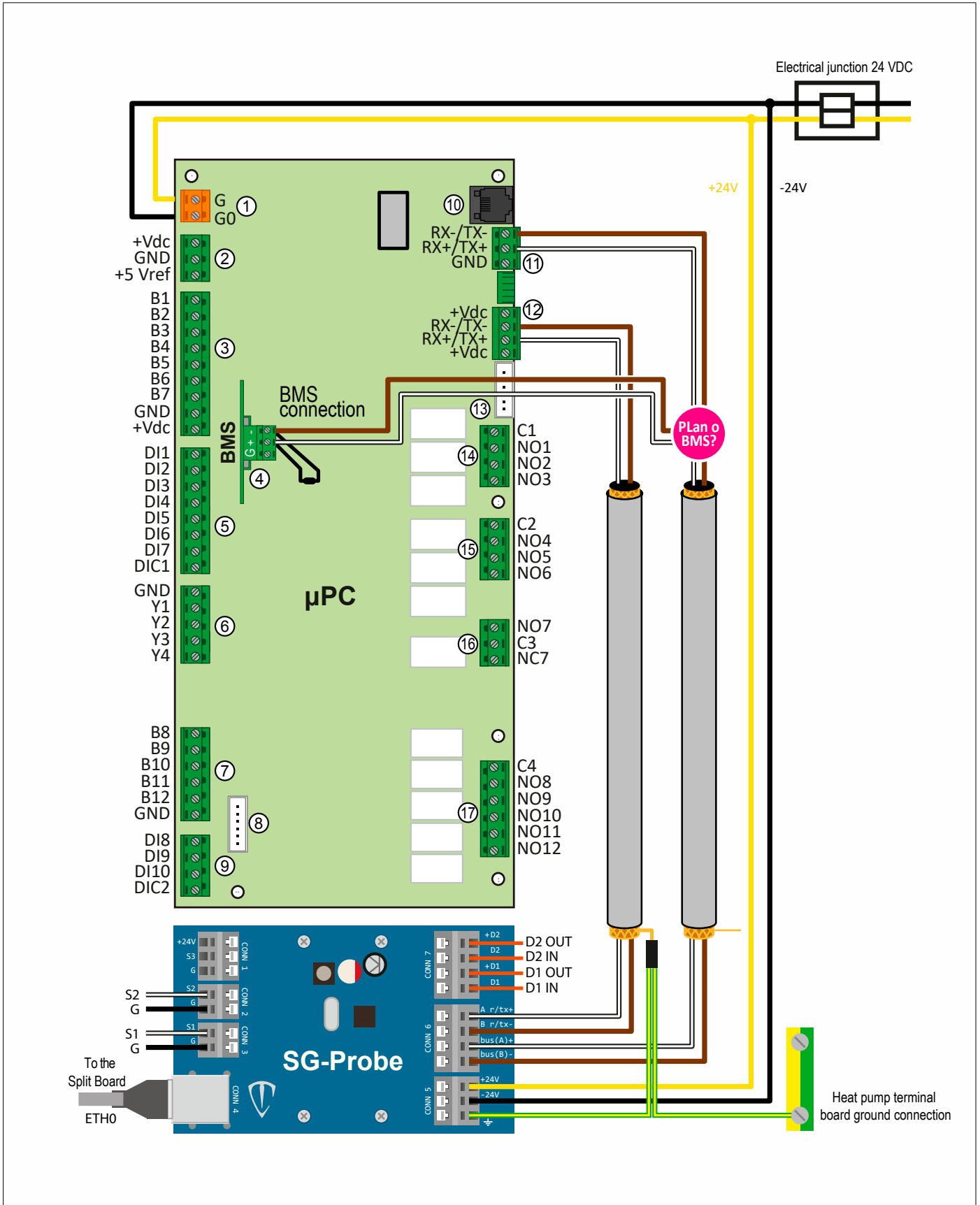

FIG. 7

12 Main electrical panel, for units with μ PC control unit

12.1 Wiring of the outdoor unit electronic controller in the main electrical panel for units with μ PC control board



Digital outputs

Ref.	Function	Ref.	Function
NO1	Integration	NO7	General alarm
NO2	Defrost	NO8	DHW integration demand
NO3	Air-air or air-water indicator	NO9	3-way valve
NO4	Circulation pump	NO10	4-way valve
NO5	Condensate drain heating	NO11	Oil heating
NO6	Plant integration demand	NO12	Desuperheater

TAB. 4 (Electronic board – Digital outputs)

Digital inputs

Ref.	Function	Ref.	Function
DI1	Summer-winter switch	DI6	Photovoltaic integration
DI2	-	DI7	Auxiliary system heater alarm
DI3	-	DI8	Remote On-Off
DI4	No power	DI9	MODBUS controller switch
DI5	Disable plant	DI10	Flow switch / Plant Aware

TAB. 5 (Electronic board – Digital inputs)

Analogue outputs

Ref.	Function	Ref.	Function
Y1	-	Y3	PWM circulation pump
Y2	KITA AIR internal unit fan	Y4	KITA AIR external unit fan

TAB. 6 (Electronic board – Analogue outputs)

Analogue inputs

Ref.	Function	Ref.	Function
B1	Subcooling	B9	Compressor discharge temperature
B2	Radiant circuit temperature	B10	Compressor suction temperature
B6	Compressor head temperature	B11	High pressure transducer
B8	External temperature	B12	Low pressure transducer

TAB. 7 (Electronic board – Analogue inputs)

12.2 SG-Probe electronic board

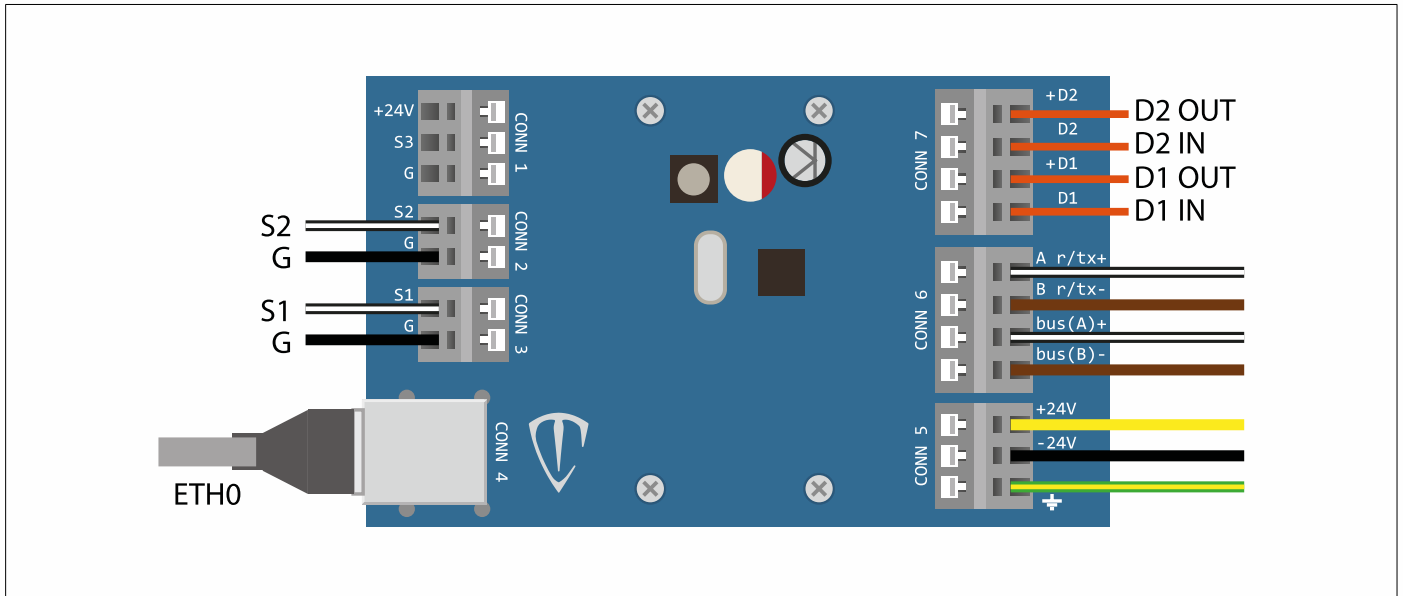

FIG. 8 SG-Probe electronic board

Ref.	Function	Ref.	Function
CONN 1	Optional probe input	CONN 5	24 Vdc power input
CONN 2	Air exchanger probe input	CONN 6	BUS input
CONN 3	Plate exchanger probe input	CONN 7	SG-Ready contact input
CONN 4	RJ45 connector for T-Split board	B12	Low pressure transducer

TAB. 8 (SG-Probe electronic board)

Analogue inputs

Ref.	Function	Ref.	Function
D1 OUT (+D1)	SG1 no-voltage contact power	S1	Air/refrigerant gas exchanger outlet temperature
D1 IN	SG1 no-voltage contact return	S2	Refrigerant plate exchanger inlet temperature
D2 OUT (+D2)	SG2 no-voltage contact power	G	Probes S1 and S2 ground
D2 IN	SG2 no-voltage contact return		

TAB. 9 (SG-Probe electronic board IN/OUT)

13 Wiring and pinout of the outdoor unit electronic controller

13.1 Main electrical panel for units with µKITA electronic control board

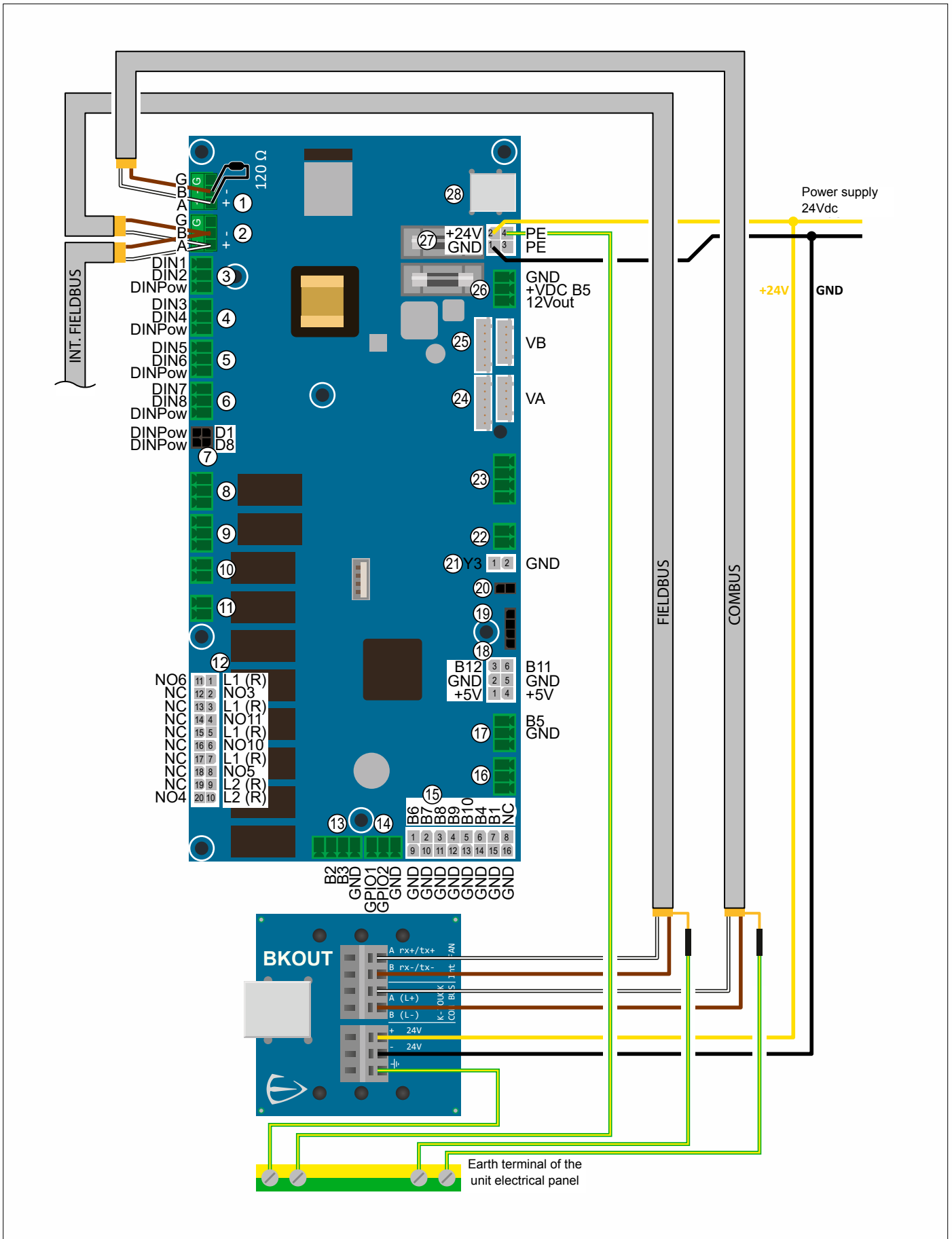

13.2 BUS Communication Ports

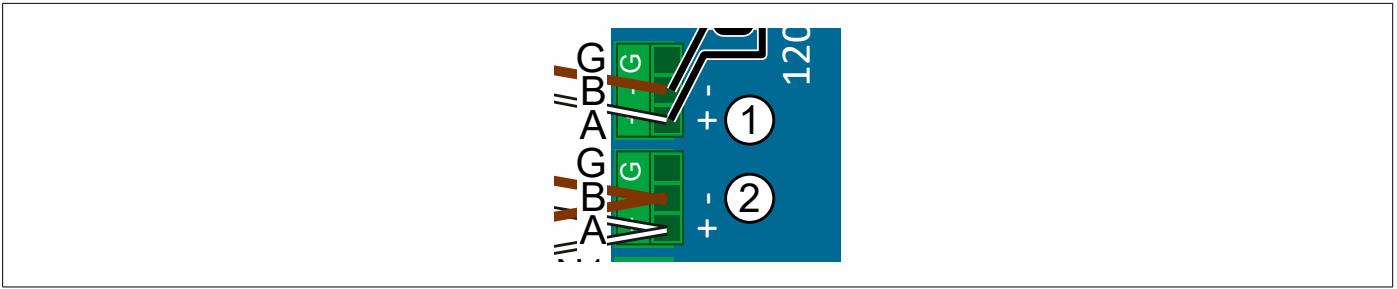

FIG. 9 (Connectors 1 and 2)

Connector	Designation	Function
1	A	A - (RX+/TX+) COMBUS Port (K-touch)
	B	B - (RX-/TX-) COMBUS Port (K-touch)
	G	GND
2	A	A - (RX+/TX+) FILEDBUS Port (Peripherals Heat Pump)
	B	B - (RX-/TX-) FILEDBUS Port (Peripherals Heat Pump)
	G	GND

TAB. 10 (Bus communication ports of the μ Kita electronic control board)

13.3 WEB Communication Port

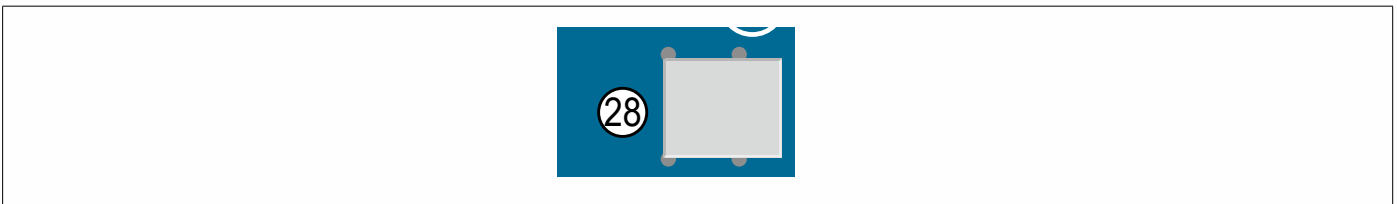

FIG. 10 (WEB communication port)

13.4 Digital inputs

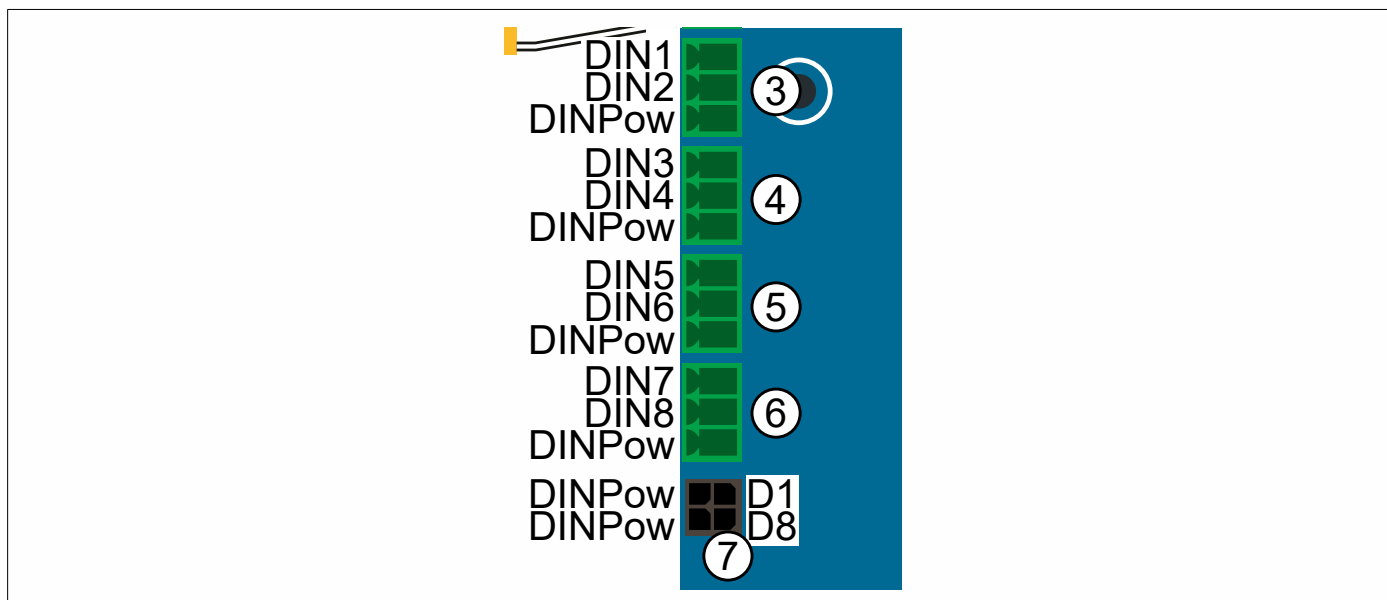

FIG. 11 (Connectors 3-7)

Connector	Designation	Function
3	DIN1	Absence of power supply
	DIN2	Flow switch*
	DIN_Pow	Power supply for digital contacts +18 V
4	DIN3	Plant disable*
	DIN4	Photovoltaic enable signal (Solar available)
	DIN_Pow	Power supply for digital contacts +18 V
5	DIN5	Auxiliary heater alarm
	DIN6	Not used
	DIN_Pow	Power supply for digital contacts +18 V
6	DIN7	Smart Grid Contact 1 (SG1)
	DIN8	Smart Grid Contact 2 (SG2)
	DIN_Pow	Power supply for digital contacts +18 V
7	DIN9	Remote Off
	DIN10	Summer/Winter switchover
	DIN_Pow	Power supply for digital contacts +18 V
	DIN_Pow	Power supply for digital contacts +18 V

*Functions available only for air-to-water heat pumps

TAB. 11 (Digital inputs on the μ Kita electronic control board)

13.5 Digital outputs

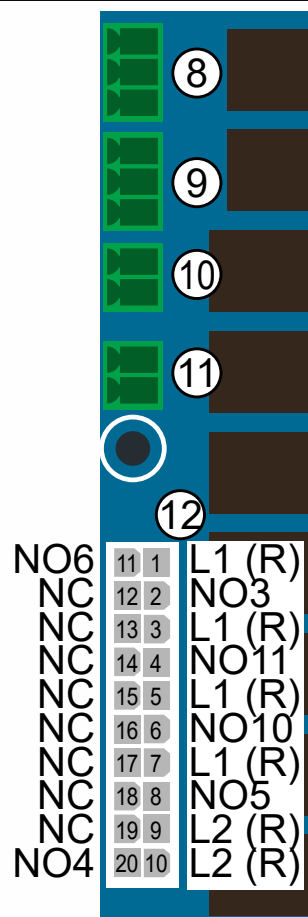

FIG. 12 (Connectors 8–12. Connectors 8 to 11 are not currently used)

Connector 12	Designation	Function
1,3,5,7	L1 (R)	Power supply phase L1 (R)
9,1	L2 (S)	Power supply phase L2 (S)
2	NO3	Booster
4	NO11	Oil Heater
6	NO10	4-way Valve
8	NO5	Anti-condensation heater
11	NO6	Plant Integration
20	NO4	Primary circulation pump*

*Functions available only for air-to-water heat pumps

TAB. 12 (Digital outputs on the μKita electronic control board)

13.6 Analogue Inputs

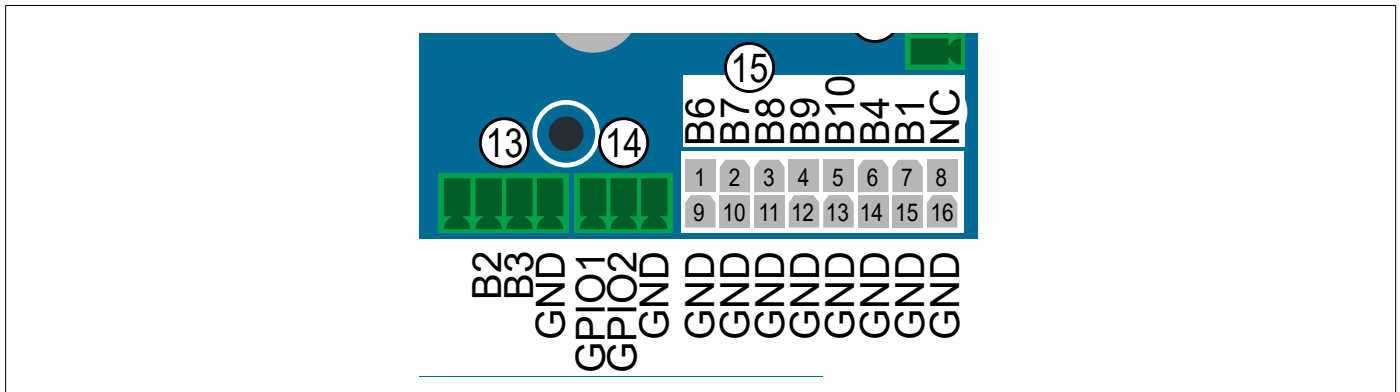

FIG. 13 (Temperature probe inputs on the µKITA electronic control board, connectors 13 and 14)

Connector	Designation	Function
13	NTC1	Not used
	NTC2 (B2)	Heating system temperature probe
	NTC3 (B3)	Domestic hot water temperature probe *
	GND	Ground
14	NTC4	GPIO1
	NTC5	GPIO2
	GND	Ground

*Functions available only for air-to-water heat pump

TAB. 13 (Temperature probe inputs on the µKITA electronic control board, connectors 13 and 14)

Connector PIN 12	Designation	Function
1	B6	Compressor head temperature probe
2	B7	Water supply temperature probe *
3	B8	Outdoor temperature probe
4	B9	Compressor discharge temperature probe
5	B10	Compressor suction temperature probe
6	B4	Water return temperature probe *
7	B1	Subcooling temperature probe
8	/	Not used
9 - 16	GND	Ground

*Functions available only for air-to-water heat pumps

TAB. 14 (Temperature probe inputs on the µKITA electronic control board, connector 12)

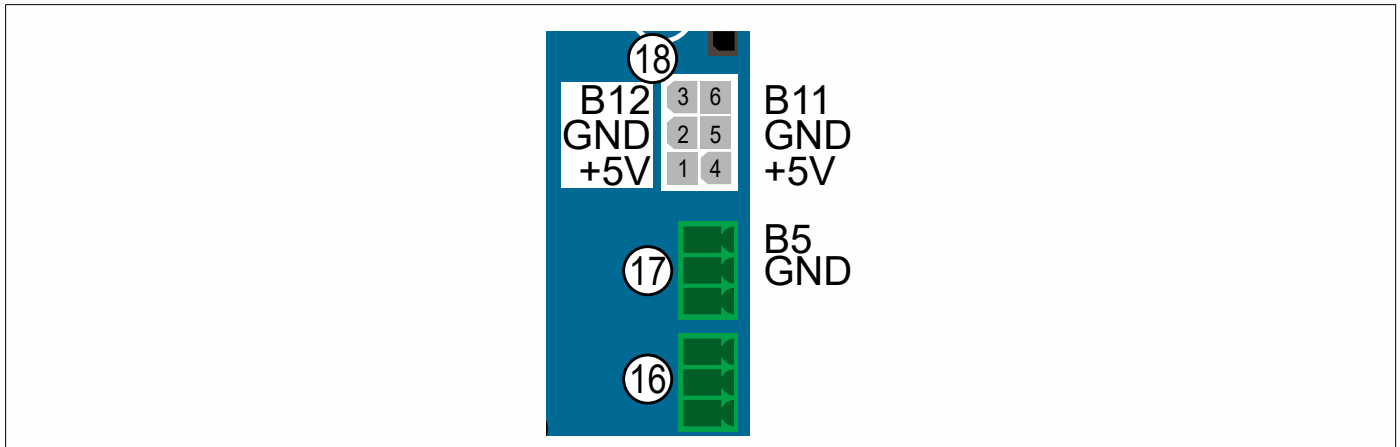

FIG. 14 (Inputs 4–20 mA on the μ Kita electronic control board, connectors 17 and 18)

Connector	Designation	Function
17	AI2	Not used
	GND	Ground
	B5	Flow meter *

*Functions available only for air-to-water heat pumps

TAB. 15 (Inputs 4–20 mA on the μ Kita electronic control board, connector 17)

Connector PIN 18	Designation	Function
1,4	+5V	Transducer power supply +5 V
2,5	GND	Ground
3	B12	High-pressure transducer
6	B11	Low-pressure transducer

TAB. 16 (Ratiometric inputs on the μ Kita electronic control board, connector 18)

13.7 PWM OUTPUT



FIG. 15 (PWM signal output on the μ Kita electronic control board, connector 21)

Connector	Designation	Function
21	Y3	Primary circulation pump PWM *
	GND	Ground

*Functions available only for air-to-water heat pumps

TAB. 17 (PWM signal output on the μ Kita electronic control board, connector 21)

13.8 Expansion valve outputs

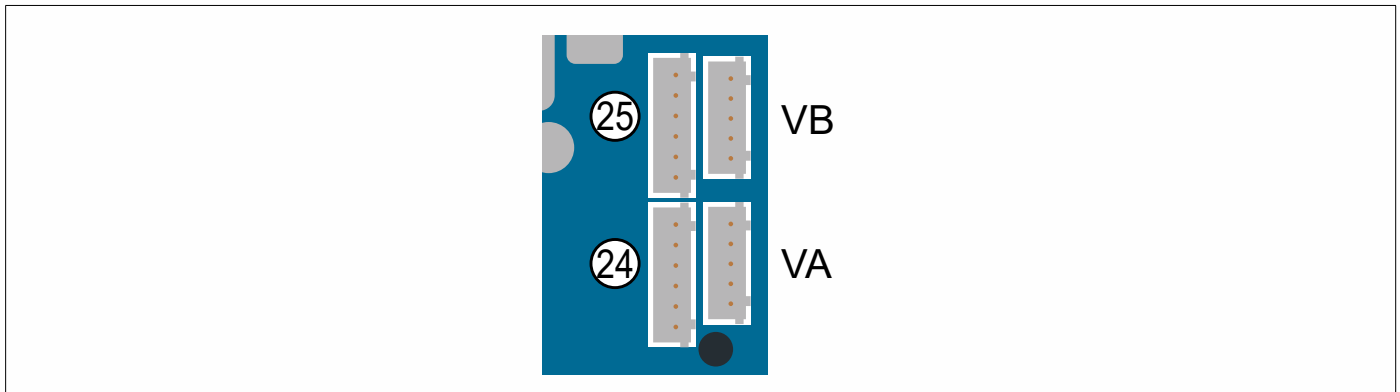

FIG. 16 (Outputs for the electronic expansion valves on the μKita electronic control board)

Connector	Designation	Function
24	VA	Electronic expansion valve
25	VB	Electronic injection valve

TAB. 18 (Outputs for the electronic expansion valves on the μKita electronic control board)

13.9 Power supply ports

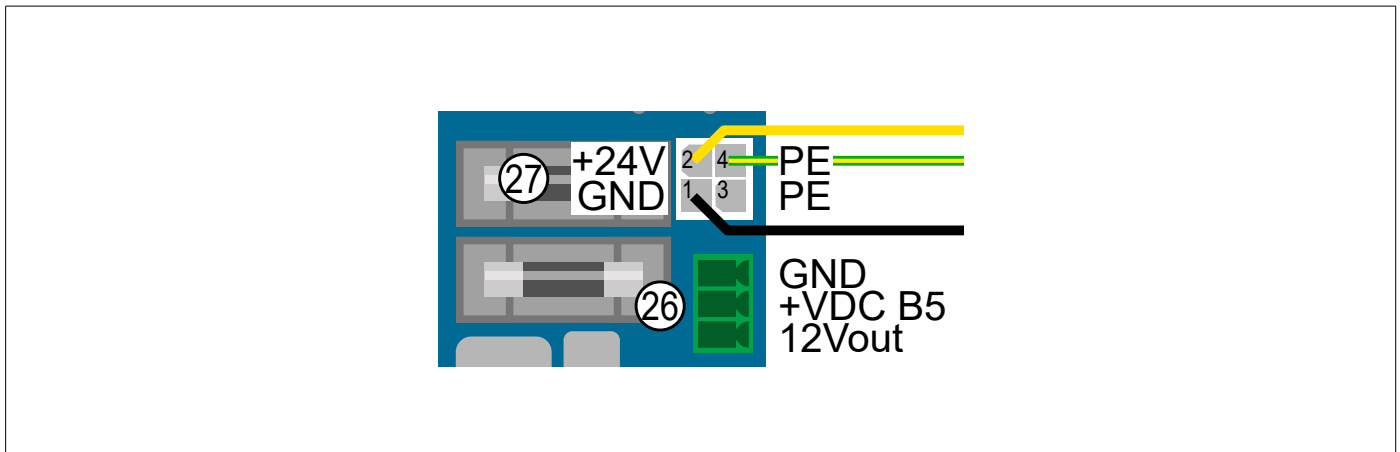

FIG. 17 (Auxiliary power supply outputs on the μKita electronic control board)

Connector	Designation	Function
26	12Vout	Auxiliary 12 VDC output
	+VDC B5	Auxiliary 24 VDC output for flow meter power supply
	GND	Ground

TAB. 19 (Auxiliary power supply outputs on the μKita electronic control board)

Connector PIN 27	Designation	Function
1	GND	Ground
2	+24V	Electronic control board power supply +24 VDC
3,4	PE	Protective Earth (PE)

TAB. 20 (Main power supply input on the μKita electronic control board)

14 Smart-Grid

14.1 Smart-Grid operation

The SG protocol makes it possible to control the heat pump's mode of operation. By reading the states of contacts SG1 and SG2, the heat pump can set its own mode of operation.

The modes of operation are given below, in relation to the states of inputs D1 (SG1) and D2 (SG2).

Mode	Description	D1 (SG1)	D2 (SG2)
1	Forced off (max 2 h): this may vary in relation to the utility company contract	1	0
2	Normal or standard operation: the heat pump is working normally according to its settings. No external action by the utility company	0	0
3	Forced on up to set power (parametrizable): the utility company enforces operation of the heat pump up to a maximum power draw, as set in the parameter MAX. Power (FIG. 54 – B12)	0	1
4a	Forced on up to maximum power without the use of electrical integration	1	1
4b	Forced on up to maximum power plus electrical integration (if available, typically the heating elements inside the buffers)	1	1

TAB. 21 Electronic board



INFORMATION

MODE 4 (4a AND 4b) CAN BE DEFINED IN TERMS OF THE SETTINGS OF PARAMETER “**EL. INTEGRATION**” (FIG. 54 – B11) WHICH, WHEN ACTIVE, TURNS ON THE DHW AND PLANT HEATERS ONLY IF THE SYSTEM IS IN HEATING MODE.

14.2 Enabling SG functions via the PGD and K-touch panel

The SG-Ready function can be enabled and configured via the PGD only on units equipped with a μ PC control board, from screens B11 and B12 (see Fig. 18). The minimum contact closure times (anti-bump) can be defined for inputs D1 (SG1) and D2 (SG2).

One can enable/disable the use of the electric heating elements for mode 4. Mode 3 configuration. Setpoint in mode 3, maximum power draw and hysteresis.

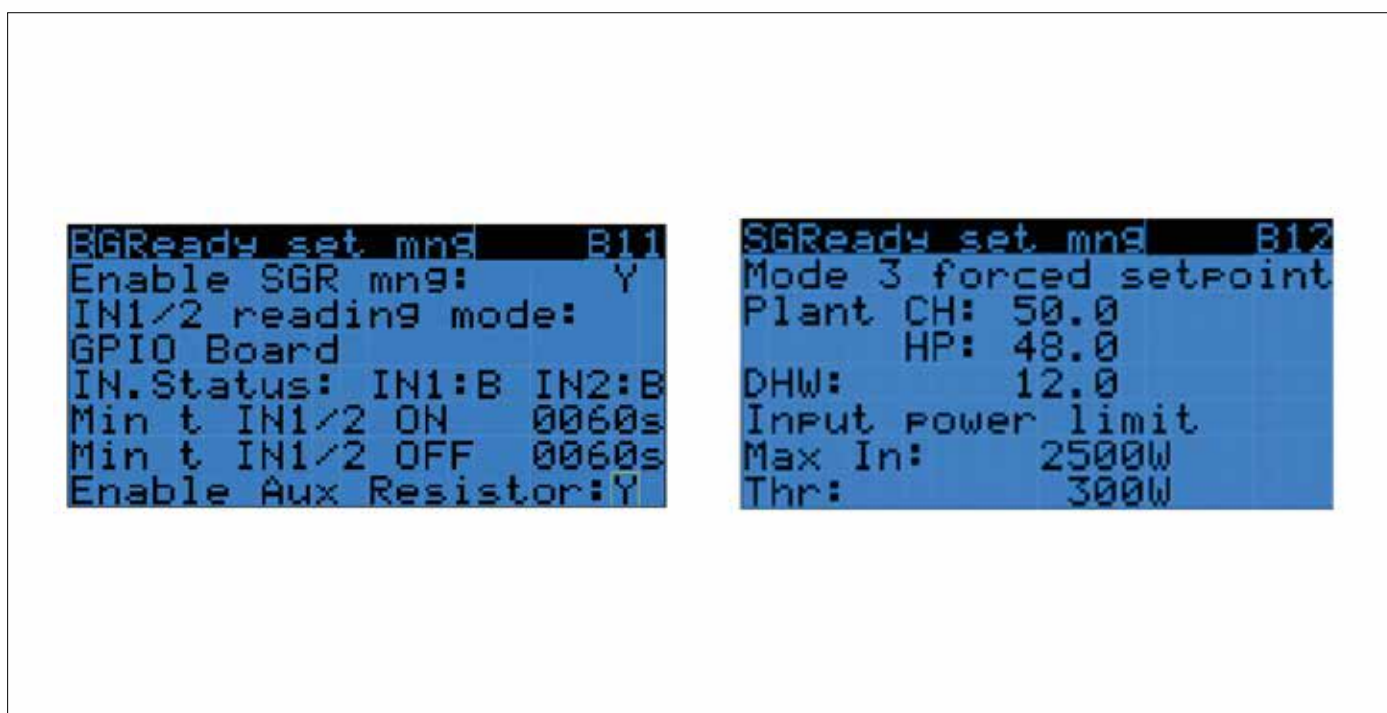
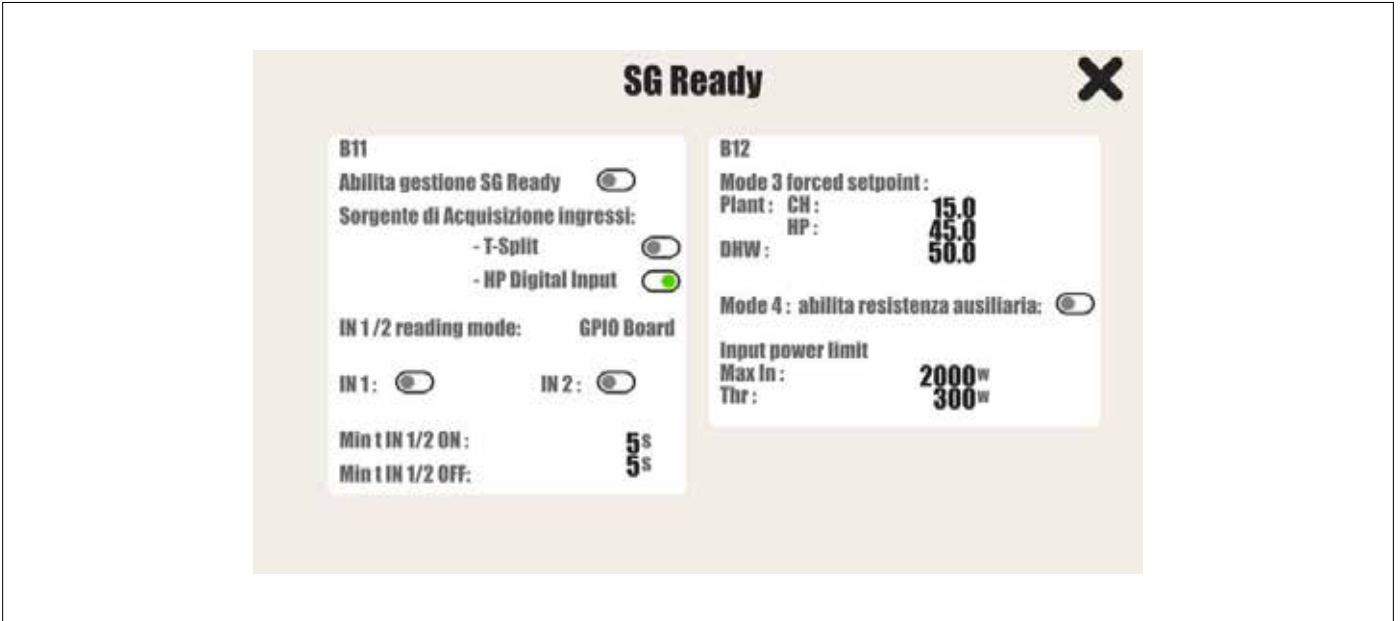

FIG. 18 (Screens B11 and B12)

For units equipped with a μ Kita electronic control board, the settings related to SG-Ready operation must be configured via the K-touch control panel on the screen shown below, accessible from the SETTINGS - ADVANCED menu.



14.3 Example of SG-Ready connection for units with μ PC and μ Kita electronic control boards

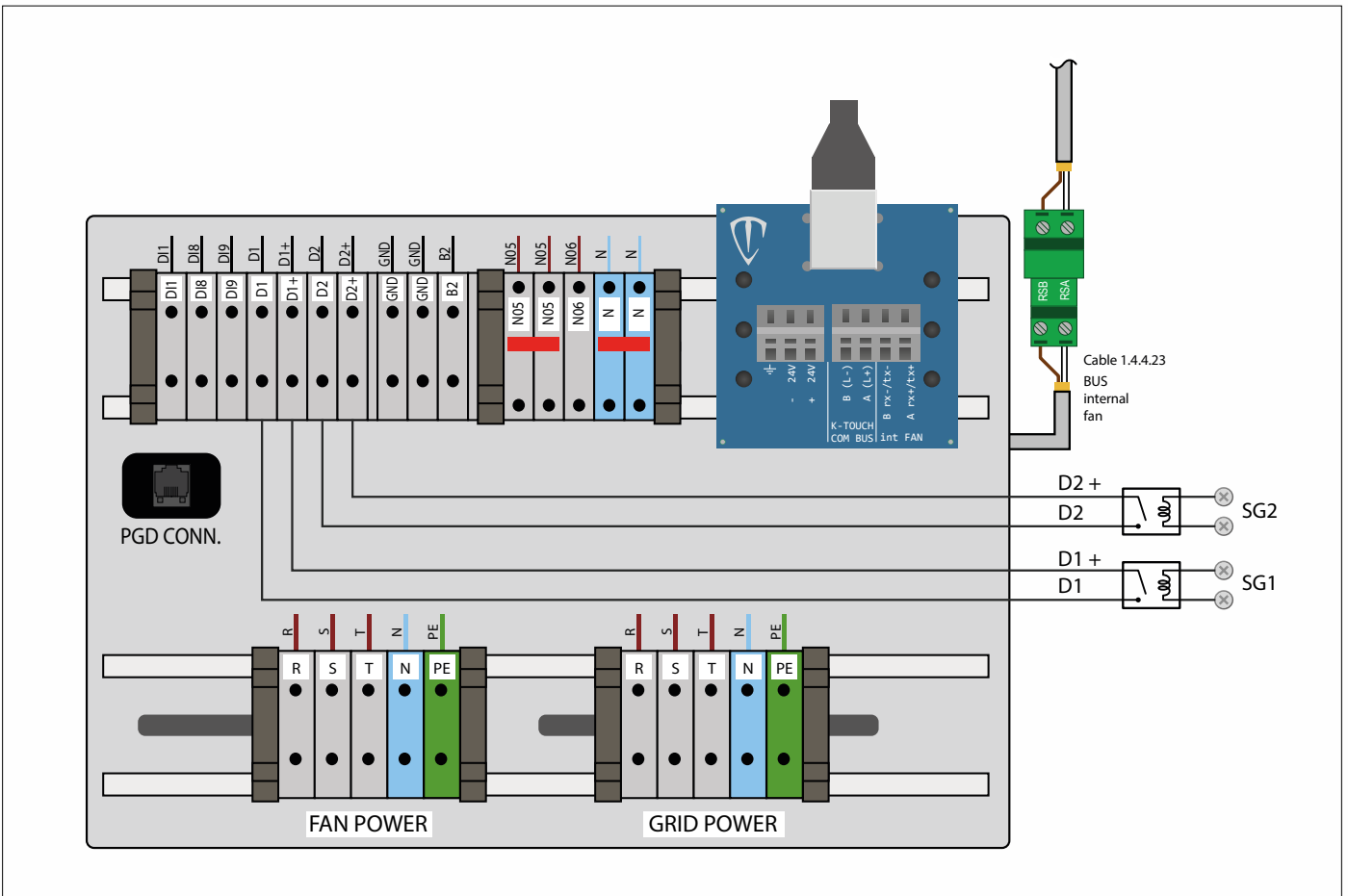
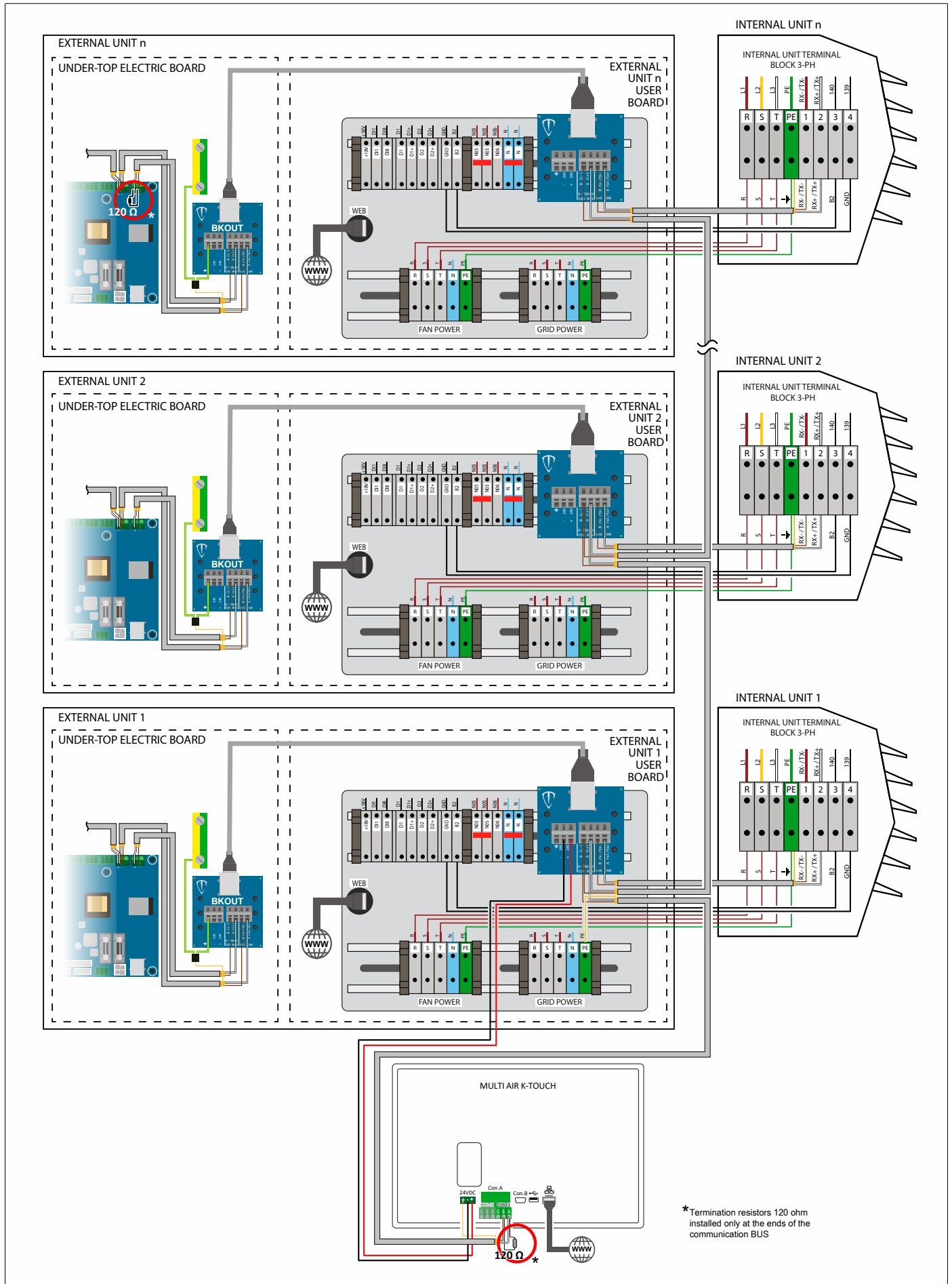

FIG. 19 (SG-Ready protocol)

15.2 Overview of the Multi-Air connection for heat pumps with a μ Kita electronic control board



16 Electric boards

16.1 Chiller compartment electric board

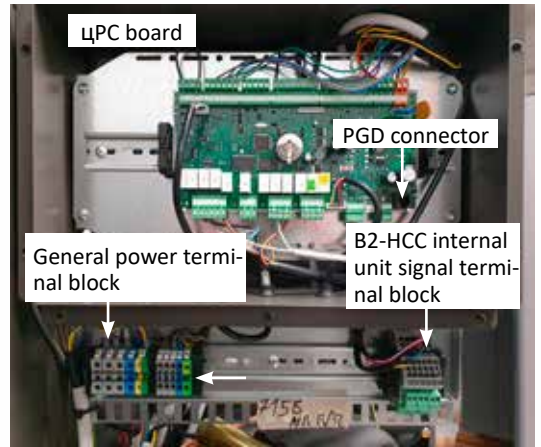

1 Overview

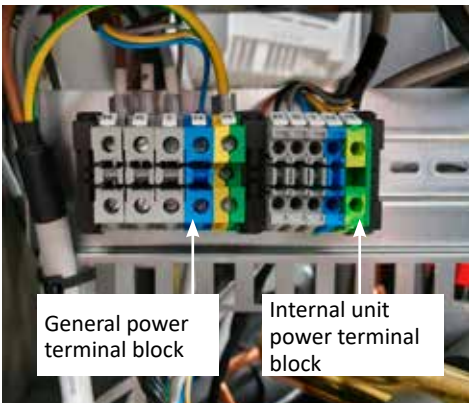

2a General power terminal block

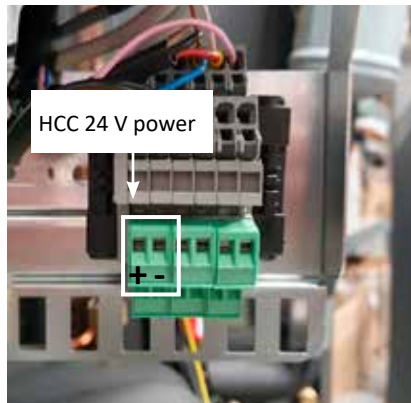

2b B2 - HCC terminal block - Internal unit signal

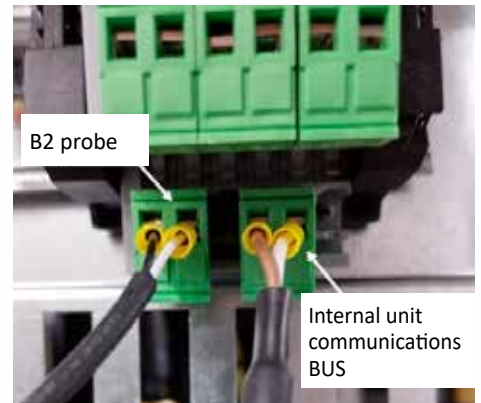

2c B2 - HCC terminal block - Internal unit signal



4 Green/yellow shield ground connection

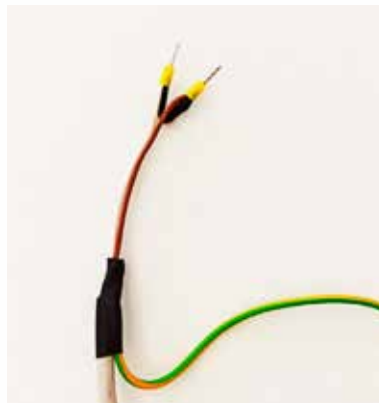

5 Shield



6 HCC touch panel connection



7a μPC PLaN connection



7b μPC BMS connection



Watch the video for the K-Touch connection to the heat pump.

16.2 Primary and secondary electrical panel for units with μ PC

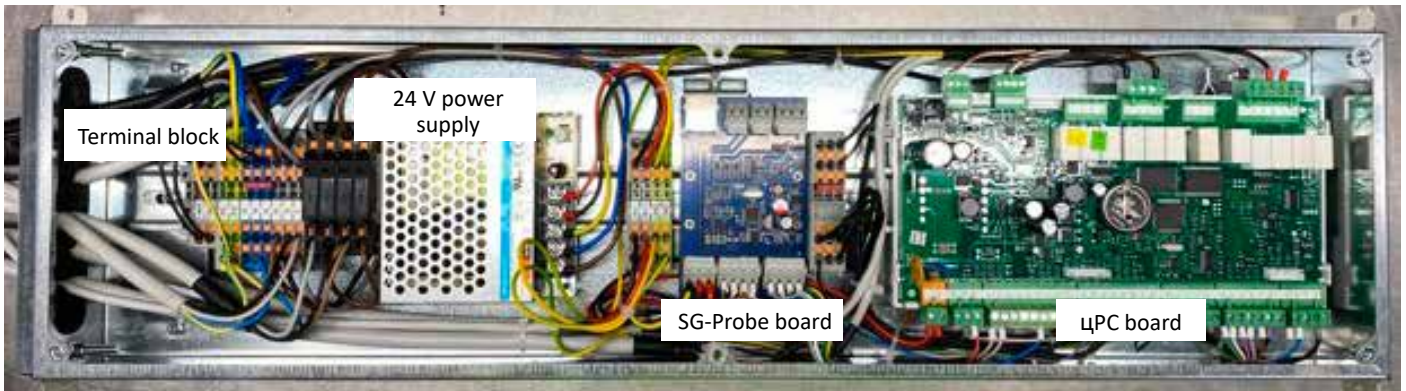

① Overview

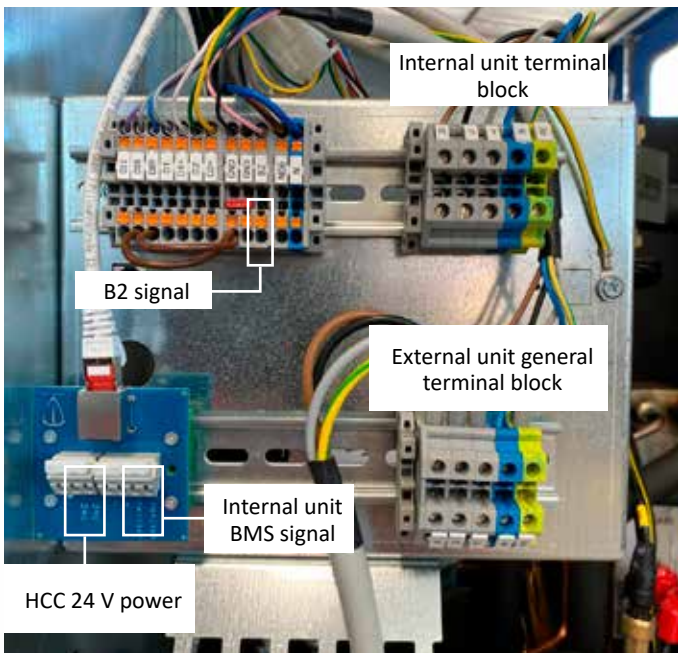

② Power (secondary panel)



③ Green/yellow shield ground connection

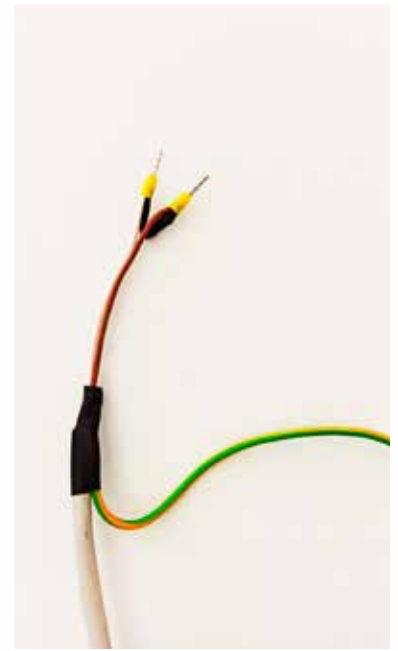

④ Shield



⑤ HCC touch panel connection



⑥a μ PC PLan connection



⑥b μ PC BMS connection



Watch the video for the K-Touch connection to the heat pump.

17 Wiring diagrams

17.1 Wiring diagram of the outdoor Air R32 unit – heat pump with μ PC electronic control board

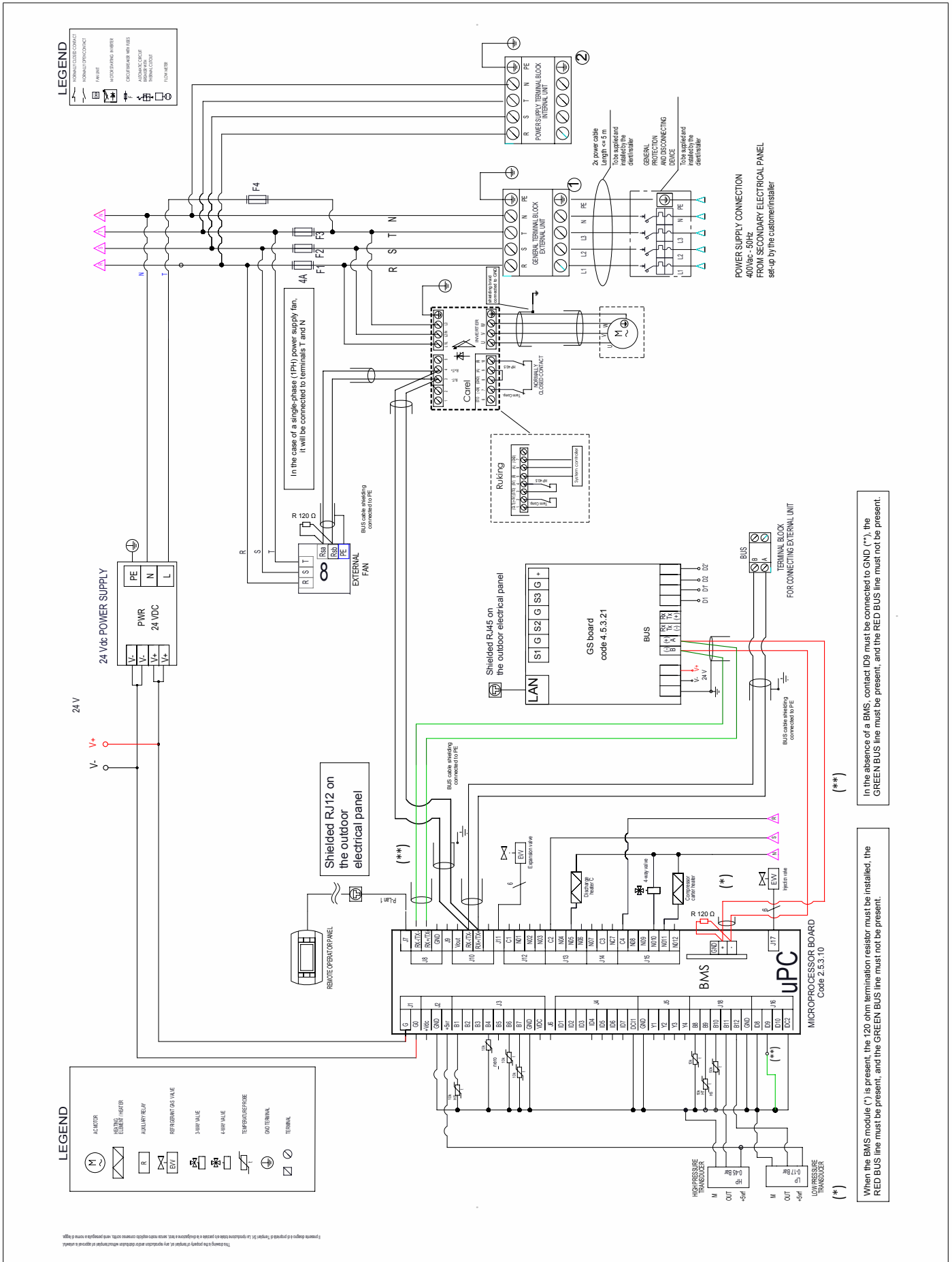

17.4 AIR R32 internal unit wiring diagram, including auxiliary heater (optional)

3 ph Heater Integration
(Optional system on request)

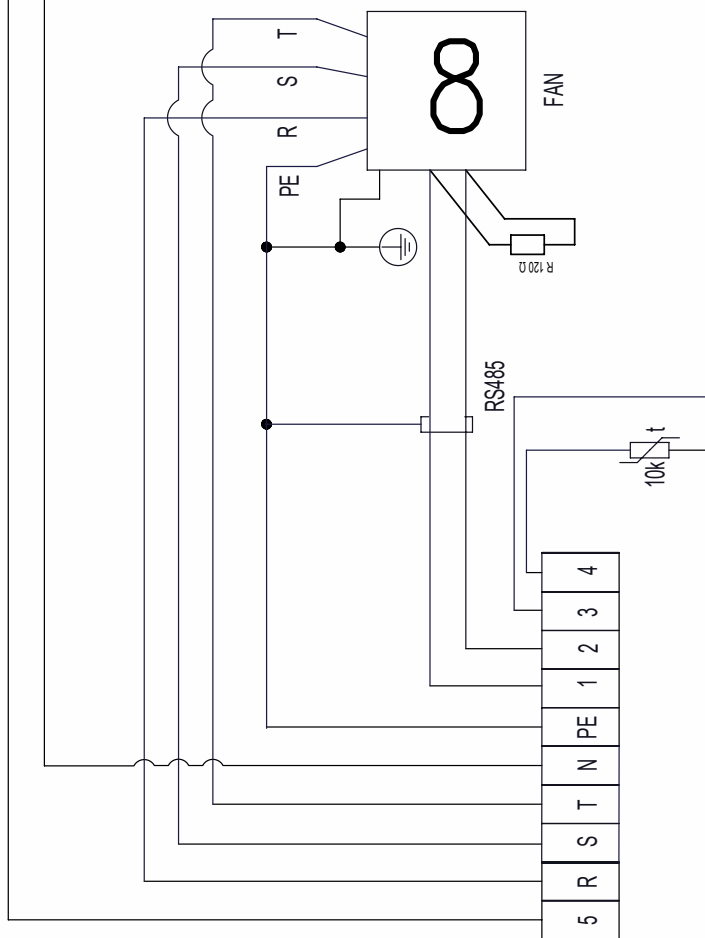
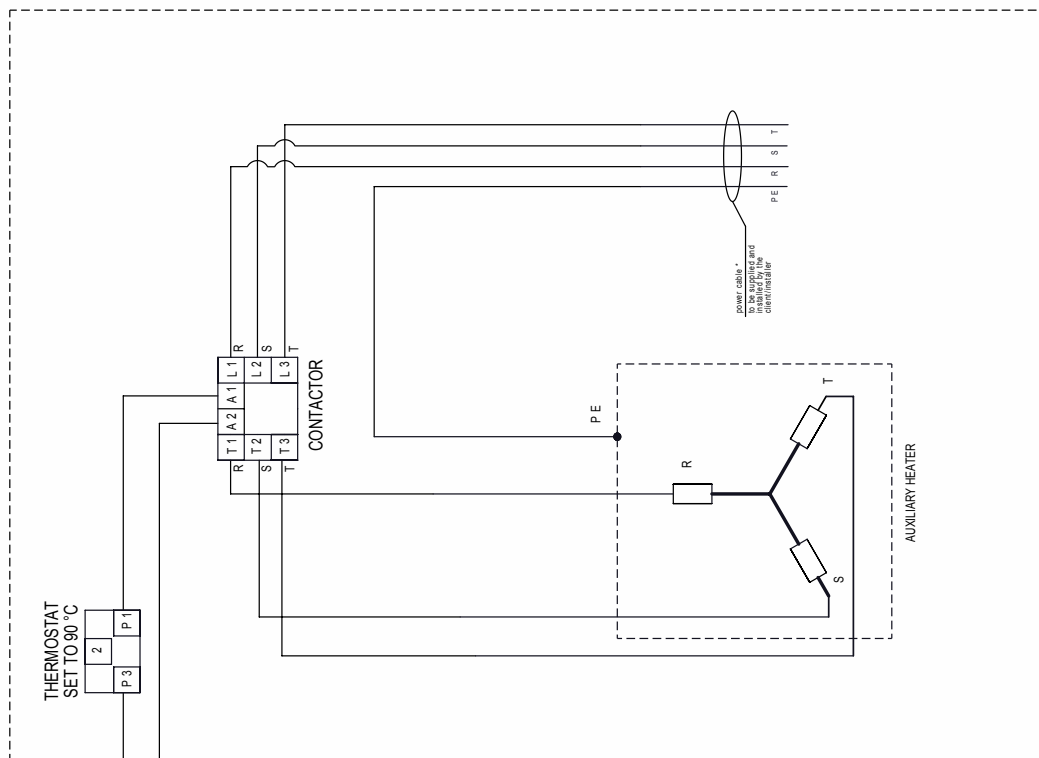

INTERNAL TEMPERATURE

1	Rx-/Tx-
2	Rx+/Tx+
3	GND
4	B2
5	NO6

18 Commissioning

The plant commissioning should be realized by technical personnel that has received a complete training.

18.1 Preliminary controls

Make sure the Heat-Pump power supply cables are of a suitable section as reported in this manual, on the basis of the power used and the length of the cables themselves and that are used the necessary electrical protective devices.

Equally check the signal cables of external unit (sensors) and internal unit too, and make sure they have the required characteristics.

Refer to this manual for using the correct type of pipes (diameter / thickness) of the refrigerant circuit between the external unit and internal unit.

After checking the above steps you can turn on the power of the machine. The unit is equipped with a phase monitoring devices, so if the control panel does not turn on and the phase devices stages presents one single red LED on, then you need to disconnect power and reverse two phases of power in order to restore the correct sequence. You can then proceed with the restart.

NOTE!

Please note that after having powered the Heat-Pump this will activate the heating of the oil automatic function (the duration of which depends on the time required to raise the temperature in the oil contained in the compressor, and then depending on the starting temperature).

NOTE!

If the internal and external units were positioned at different heights, with a vertical drop of more than 3 meters, it is necessary to use siphons for the oil recovery every 4 meters in the cooling line called "GAS."

18.2 Commissioning

Running of the compressor:

Every HP is tested in the company before the supply, but we suggest in any case to make a short running in, so not to solicitate overly the new compressor. In this regard we suggest to let in manual the rps compressor at a medium value (50-60 rps) for one/two hours at least.

- Access to menu "Assistance": PRG --> G. Assistance --> g. Manual management --> SERVICE PASSWORD
- Screen Gg05 set up CH/HP in manual "MAN" and set up the rps (60). Now turn on the heat pump (Mode ON) and wait for some minutes until the compressor icon appears in the lower left.

Verify the proper operation:

- Access to menu "D. inputs/outputs" to control the different temperatures from sensors
- Screen D01: B1 it shows the value of liquid sub-cooling in the heat pump, it has to stay in a range between 3,5 and 5. If the hp is started up during the hot season, for the check of sub-cooling set up the fan speeds (Menu G. Assistance --> g. Manual management --> G. Assistance --> g. Manual

management --> SERVICE PASSWORD --> Screen Gg02: set up "Speed Fan" in manual MAN and "Power required" at 5%.

- Screen D08: verify that the value SH (overheating) is included between 4 and 5
- Screen D15: verify, once set these conditions the drain overheating has to be about 20. During the normal operation, with free compressor, this value can reach 45K.
- Screen D16: control the proper operation of the injection valve, considering that over 12°C external the valve is off.
- Menu G. Assistance --> g. Manual management --> G. Assistance --> g. Manual management --> SERVICE PASSWORD --> Screen Gg06: activate a defrosting forced cycle, setting up "Start the defrost cycle" in YES (once ended the cycle the function automatically come back to AUT).
- Restore all settings from manual MAN to automatic AUT.
- Verify that the working tensions and network frequencies are in the following ranges:
230/1/50 -> valori \pm 6%
400/3/50 -> valori \pm 6%

NOTE!

A problem easily detectable is the steady opening of the electronic valve at 100%

possible reasons and solutions:

- lack of refrigerant gas in the cooling system; for this reason the electronic valve, to compensate the lack of gas, is open over the normal values.
- heat pump used in incorrect way. Example: installation of a heat pump undersized respect to the building that requires more power at rating levels. In this case for example the compressor works at 100% even with positive air temperatures; this fact requires an higher quantity of refrigerant than the project data. The heat pump Kita has to be sized to work at full speed just at minimum external temperatures. The electronic valves are optimized to work in the medium range of operation and for this reason oversized valves aren't installed, they would work too close causing instability in the system. Possible solutions:
 - control the proper operation of the valve
 - control that in the HP Kita there is the right quantity of gas
 - replace the heat pump if wrongly undersized resoect

19 Alarms

Alarm code	Visualized message	Reset	Delay	Relay	Action
ALA01	Probe B1 broken or disconnected	Automatic	60 sec	Yes	Stop the machine
ALA02	Probe B2 broken or disconnected	Automatic	60 sec	Yes	If there is a geothermal modulating pump it is set at the maximum speed
ALA03	Probe B3 broken or disconnected	Automatic	60 sec	Yes	Stop the regulation of the domestic circuit
ALA04	Probe B4 broken or disconnected	Automatic	60 sec	Yes	Stop the machine
ALA05	Probe B5 broken or disconnected	Automatic	60 sec	Yes	Stop the pump of the solar collector
ALA06	Probe B6 broken or disconnected	Automatic	60 sec	Yes	Stop the functions enabled by the outside probe
ALA07	Probe B7 broken or disconnected	Automatic	60 sec	Yes	Stop the machine
ALA08	Probe B8 broken or disconnected	Automatic	60 sec	Yes	Stop the pump of the solar collector
ALA09	Probe B9 broken or disconnected	Automatic	60 sec	Yes	If Siam compressor stops the compr.
ALA10	Probe B10 broken or disconnected	Automatic	60 sec	Yes	If there is the electronic expansion valve it stops the machine
ALA11	Probe B11 broken or disconnected	Automatic	60 sec	Yes	Stop the machine
ALA12	Probe B12 broken or disconnected	Automatic	60 sec	Yes	Stop the machine
ALB01	Position: ID3 High pressure	Manual	Immediate	Yes	Stop the machine
ALB02	High pressure of the compressor 1 from transducer	Manual	Immediate	Yes	Stop the machine
ALB03	Low pressure of the compressor/s from transducer	Automatic (par. Hc05)	At the start: 40s (par. Hc03) at regime: 10s (par. Hc04)	Yes	Stop the machine
ALC01	Position: ID2 Thermal compressor 1 or allarm inverter	Manual	Immediate	Yes	If 1 comp. enabled: stop the machine If 2 comp. enabled: stop comp.1 (if comp. 2 is available)
ALC02	Position: ID9 Thermal compressor 2	Manual	Immediate	Yes	Stop comp.2 (if comp. 1 is available)
ALC03	Alarm envelope: 0: Max.rel.compr. 1: Max.press.drain 2: Power limit 3: Max.press.suc. 4: Min.rel.compr. 5: Min.diff.pressure. 6: Min.press.drain 7: Min. press.suc. Compressor off for working out of envelope (only with compressor Siam)	Manual	60 sec (par. H1b14)	Yes	Stop the compressor
ALC04	Alarms missing start of the compressor (only with compressor Siam)	After 5 times per hour it becomes manual	60 sec (par. H1b11)	Yes	Stop the compressor
ALC05	Max.drain time (only with compressor Siam)	After 3 times per hour it becomes manual	Immediate	Yes	Stop the compressor
ALC06	Delta pressure < minimum request for the return of the compr. oil (only with compressor Siam)	Automatic	120 sec (par. H1b12)	Yes	Stop the compressor
ALP01	Position: ID1 Flow switch geothermal circ. water	After 5 times per hour it becomes manual	At the start: 15s (par. Hc15) at regime: 5s (par. Hc16)	Yes	Stop the machine at maximum time reached
ALP02	Position: ID4 Thermal pumps	Manual	Immediate	Yes	Stop the machine
ALP03	Positions: ID10 Flow switch primary circuit water	After 5 times per hour it becomes manual	At the start: 15s (par. Hc12) at regime: 5s (par. Hc13)	Yes	Stop the machine at maximum time reached
ALP04	Position: ID5 Thermal pump solar circuit	Manual	Immediate	Habilitable (Gfc01)	Stop the pump of solar collector
ALR01	Position: ID7 Alarm boiler/ resistance integr. system	Automatic	Immediate	Habilitable (Gfc02)	Stop boiler/ resistance operation primary circuit integration
ALR02	Position: ID6 Thermic boiler/resistance DHW from digital input	Manual	Immediate	Settable (Gfc03)	Stop operation boiler/resistance integration DHW
ALF01	Position: ID1 Thermic fan	Manual	Immediate		Stop the machine
ALT01	Threshold reached worked hours by the compressor 1	Manual	Immediate	Settable (Gfa01)	Only signal
ALT02	Threshold reached worked hours by the compressor 2	Manual	Immediate	Settable (Gfa01)	Only signal
ALT03	Threshold reached worked hours by the geothermal pump	Manual	Immediate	Settable (Gfa01)	Only signal
ALT04	Threshold reached worked hours by primary circ. pump	Manual	Immediate	Settable (Gfa01)	Only signal

Alarm code	Visualized message	Reset	Delay	Relay	Action
ALT05	Reached threshold worked hours pump DHW	Manual	Immediate	Settable (Gfa01)	Only signal
ALT07	Threshold reached worked hours solar pump	Manuale	Immediate	Settable (Gfa01)	Only signal
ALT08	Threshold reached worked hours outside battery fan	Manual	Immediate	Settable (Gfa01)	Only signal
ALU01	Geothermal frosting protection exchanger	Manual (par. Gfc28)	Immediate	Yes	Stop the machine
ALU02	Frosting protection primary exchanger	Manual (par. Gfc32)	Immediate	Yes	Stop the machine
ALU03	Overheating exchanger	Manual	Immediate	Yes	Stop the machine
ALW01	Threshold reached high domestic water	Automatic	60 sec	Habilitable (Gfc01)	Only signal
ALW02	Threshold reached maximum domestic temperature at solar collector	Automatic	60 sec	Yes	Only signal
ALW03	Exceeded max. time to defrosting end	Automatic	Immediate	Yes	Only signal
ALD01	Alarm EEPROM	Manual	Immediate	Yes	Stop the machine
ALD02	Probe EVD EVO broken or disconnected	Automatic	Immediate	Yes	Stop the machine
ALD03	Engine error EEV	Manual	Immediate	Yes	Stop the machine
ALD04	Low overheating (LowSH)	Manual	Immediate	Yes	Stop the machine
ALD05	Low suction temperature	Manual	Immediate	Yes	Stop the machine
ALD06	Evaporation low temperature (LOP)	Manual	Immediate	Yes	Stop the machine
ALD07	High evaporation pressure (MOP)	Manual	Immediate	Yes	Stop the machine
ALD08	High condensation temperature (HiTcond)	Manual	Immediate	Yes	Stop the machine
ALD09	Driver offline	Automatic	Immediate	Yes	Stop the machine
ALL01	Device Power+ n. 1 Offline	Automatic	30 sec	Yes	Stop the machine
ALL02	Alarms Power+ n.1 0: No error 1: Overpower 2: Overp. engine 3: Overvoltage 4: Undervoltage 5: Overtemperature 6: Undertemperature 7: Overpower HW 8: Overtemp. engine 9: Reserved 10: Error Cpu 11: Param. default 12: Undulation DC bus 13: timeout com.ser. 14: Error thermistor 15: Error Autotuning 16: Drive disabled 17: Engine phase missing 18: Broken fan 19: Engine stalling	Manual	Immediate	Yes	Stop the machine

The letter preceding the number has the following meaning

A	"AIN" Physic probes broken uPC	P	"Pumps" Pumps flow switches, pumps thermic
B	"Boh" Alarms blocking the Circuit, High-Low pressure..	Q	"Quality" HACCP, Consumptions
C	"Compressor" Thermic, envelope	R	"Remote" Various alarms from digital inputs
D	"Driver" Electronic valve	S	"Serial probe" Serial probes
E	"Expansion" Alarms uPCe	T	"Timing" Warning maintenance
F	"Fan" fan	U	"unit" Alarms blocking the unit
G	"Generic" general alarm, Clock broken, HW, Memory	V	"VFD" Alarms inverter
H	"Humidifier" humidifier	W	"Warning" generic
I	"Fancoil" alarms coming from and hydronic net	X	Defrosting
M	"MP-BUS" / Belimo	Y	Climate
O	"Offline" Offline supervisor, offline pLAN		

19.1 Alarms resolution

Alarm code	Causes	Solution proposed
ALB01	Condensation high pressure, the most of times this alarm is caused by the too high set of the water produced both in heating than in DHW. Other very frequent causes are: the wrong positioning of regulation probes (B2 and B3) compared to the flow of the unit and the insufficient water flow to plate heat condenser.	1)place the probes B2 and/or B3 at the same height as the input flow accumulation of the machine.
ALB02	See ALB01	See ALB01
ALB03	The low pressure from transducer can be connected to dynamic inside the machine. But it can also be symptom of a malfunction of the transducer or a refrigerant loss.	If the alarm is frequent 2/3 consecutive times in 4-6 hours inspect the unit with a leak detector and contact the assistance.
ALC03	Alarm envelope, the compressor is out from its field of work. In this case the reasons can be several and not listable.	We suggest at first to consider the use of the unit that can be incoherent with the work field of the unit, for example, operation DHW with outside too high temperatures. See the section "operative zone allowed" of this manual.
ALC04	The compressor can't create a minimum pressure delta in a certain interval of time, the cause can be the inertia of the system and the nearness between the temperatures of air and water	If it occurs occasionally, it's just a no serious signal permitting to the unit to keep on working.
ALP03	Flow loss in the hydraulic system, caused by air in the system, solid particles or excessive flow loss	Vent the system of all the air, regular cleaning of the system. Avoid excessive pressure loss in the hydraulic circuit, in particular avoid restrictions in the system.
ALW03	Caused by air currents cooling the coil finned during the defrosting procedure	Study a different positioning of the machine or block the wind addressed to the unit.
ALD04	Alarm which depends on the dynamics inside the machine	Contact the assistance
ALD06	Alarm which depends on the dynamics inside the machine	Inspect the unit with leak detector and contact the assistance
ALD07	Alarm which depends on the dynamics inside the machine	Contact the assistance
ALL01	Missing communication between inverter and electronic board caused by slight power surges and current or by electromagnetic fields disturbing the network	Check the counter powering the machine, avoid to overload it, check the domestic line, avoid electromagnetic fields nearby
ALL02	Missing communication between inverter and electronic board caused by strong power surges and current or electromagnetic fields disturbing the network	Check the counter powering the machine, avoid to overload it, check the domestic line, avoid electromagnetic fields nearby. The contact the assistance.

19.2 Notifications

Notification	causes
Heat Transfer Limited	It occurs when the difference between the value of the B7 and B2 probes in the case of heating operation, or the difference between B7 and B3 probes in the case of DHW production, is excessive.
Power limit temperature	It is activated if the heat pump is producing water less than 6 ° or more than 58 °. The compressor is moves to a minimum speed to avoid generating an error.
Irregular waterflow	Since the heat pump was powered, at least once a problema of flow occurred. After five of these notificatios, the next one is a flow error.

20. Summary of changes

Data	Sezione/paragrafo	Modifica
13/09/2025	3.4 Modalità di funzionamento	Aggiornamento immagine "Modalità di raffreddamento"
12/03/2026 17/04/2026	10.6 Alimentazione	Revisione dei valori in tabella
	10.8 Quadro elettrico utente con scheda di controllo μ PC	Aggiornamento dell'immagine e della tabella (TAB. 1)
	10.9 Quadro elettrico utente con scheda di controllo μ kita	Inserimento del nuovo paragrafo
	10.11 Connessione unità interna - unità esterna, per PDC con scheda di controllo μ PC	Aggiornamento dell'immagine
	10.12 Connessione unità interna - unità esterna, per PDC con scheda di controllo μ Kita	Inserimento del nuovo paragrafo
	11.2 Pannello K-Touch, connessioni elettriche	Correzione della visualizzazione dell'immagine
	11.3 Collegamento alla pompa di calore e utilizzo simultaneo PGD - solo per PDC con scheda elettronica di controllo μ PC	Aggiornamento del titolo
	13 Cablaggio e pin-out centralina elettronica unità esterna	Inserimento del nuovo capitolo
	14.2 Abilitazione funzioni SG tramite PGD e pannello K-touch	Aggiornamento del titolo
	14.3 Esempio di collegamento SG-Ready per macchine con scheda elettronica di controllo μ PC e μ Kita	Aggiornamento dell'immagine
	15.1 Panoramica per il collegamento Multi-Air per PDC con scheda elettronica di controllo μ PC	Aggiornamento del titolo e dell'immagine
	15.2 Panoramica per il collegamento Multi-Air per PDC con scheda elettronica di controllo μ Kita	Inserimento del nuovo paragrafo
	17.1 Schema elettrico unità esterna Air R32- PDC con scheda elettronica di controllo μ PC	Aggiornamento dello schema elettrico
	17.2 Schema elettrico unità esterna Air R32 - Singola alimentazione - Pdc con scheda elettronica di controllo μ Kita	Inserimento del nuovo paragrafo
17.3 Schema elettrico unità esterna Air R32 - Doppia Alimentazione - Pdc con scheda elettronica di controllo μ Kita	Inserimento del nuovo paragrafo	
	12 Main electrical panel, for units with μ PC control unit	Aggiornamento titolo

Templari S.p.a.

via Cesare Battisti, 169
35031 Abano Terme (PD)
Italy

Tel. +39 049 8597400
info@templari.com

www.templari.com

